

TECHNICAL MANUAL

**DIRECT SUPPORT, GENERAL SUPPORT AND
DEPOT MAINTENANCE MANUAL**

**INCLUDING REPAIR PARTS AND SPECIAL TOOL LISTS
RADAR SET AN/PPS-4A**

(NSN-5840-00-168-1566)

**This copy is a reprint which includes current
pages from Changes through 4.**

HEADQUARTERS, DEPARTMENT OF THE ARMY

AUGUST 1971

WARNING NOTICES

DANGEROUS VOLTAGES EXIST IN THIS EQUIPMENT

Be careful when working on the plate, collector, and de power supply circuits.

DON'T TAKE CHANCES

EXTREMELY DANGEROUS VOLTAGES EXIST IN THE FOLLOWING UNIT

Receiver-Transmitter Radar RT-7652/PP4 5,000-volt circuits

Dangerous voltages are developed in pulse unit Z201 (fig. 3-14), on magnetron VO1 (fig. -7/4), and on cable connecting magnetron V901 with Pulse unit Z201.

No.11-5840-21145

DIRECT SUPPORT, GENERAL SUPPORT, AND DEPOT MAINTENANCE MANUAL

RADAR SET AN/PPS-4A
(NSN 5840-00-168-1566)

		Paragraph	Page
CHAPTER	1.	INTRODUCTION	1-1--1-3 1-1
CHAPTER	2.	FUNCTIONING OF EQUIPMENT	
Section	I.	System function	2-1--2-10 2-1, 2-2
	II.	Complete block diagram 211-2-13	2-11, 2-3, 2-4
	III.	Transmitting system function	2-14--2-22 2-8--2-15
	IV.	Rf system function _	2-2-- 2-20 2-16 2-20
	V.	Receiving system function	2-31- 2-38 2-23-2-29
	VI.	Automatic frequency control system function	2-39--2-46 2-30--2-35
	VII.	Ranging system function	2-47--2-53 2-36--2-46
	VIII.	Audio system function	2-54--2-57 2-48--2-50
	IX.	Automatic gain control system function	2-58--2-62 2-50, 2-51
	X.	Power converter system function	2-63--2-66 2-54--2-56
	XI.	Control system function _	2-67--2-74 2-58--2-43
CHAPTER	3.	DIRECT SUPPORT MAINTENANCE	
Section	I.	General	3-1, 3-2 3-1
	II.	DS troubleshooting	3-3--3-25 3-2--3-47
	III.	Adjustment and alignment --	3-26--3-52 3-51--3-70
	IV.	Repair - -	3-53--3-58 3-72, 3-73
	V.	Removal and replacement -	3-59--3-71 3-73--3-94
CHAPTER	4.	DIRECT SUPPORT TESTING PROCEDURES	4-1--4-25 4-1--4-12
CHAPTER	5.	GENERAL SUPPORT MAINTENANCE	
Section	I.	General _	5-1, 5-2 5-1
	II.	GS troubleshooting --	5-3--5-26 5-1--5-17
	III.	Repair, removal and replacement	5-27--5-36 5-17--5-23
	IV.	Disassembly and reassembly of tripod -	5-37--5-42 5-24--5-33
CHAPTER	6.	DEPOT MAINTENANCE -	6-1, 6-2 6-1
CHAPTER	7.	DEPOT OVERHAUL STANDARDS	
Section .	I.	General -	7-1--7-3 7-1
	II.	Tests -	7-4--7-13 7-2--7-7
APPENDIX	A.	REFERENCES	A-1
	B.	DIRECT SUPPORT, GENERAL SUPPORT, AND DEPOT MAINTENANCE REPAIR PARTS AND SPECIAL TOOLS LISTS Deleted	
INDEX		I-1

LIST OF ILLUSTRATIONS

Figure No.	Title	Page
2-1	Basic timing circuit	2-4
2-2	Transmitting system, block diagram	2-9
2-3	Microwave assembly, complete schematic diagram	2-11
2-4	Unijunction transistor characteristics	2-12

*This manual supersedes TM 11-5840-211-35, 18 July 1961, including all changes.

Figure No.	Title	Page
2-4	Simplified version of silicon controlled rectifier	2-13
2-6	Four-layer diode current characteristics - _	2-14
2-7	RF system, block diagram -	2-17
2-8	Waveguide characteristics - -	2-18
2-9	Choke joints	2-18
2-10	Section of dual-channel limiter	2-19
2-11	Path of signal in balanced mixer	2-21
2-12	Energy flow in microwave assembly of rf system - _	2-22
2-13	Antenna, functional schematic diagram	2-23
2-14	Antenna radiation pattern	2-23
2-15	Receiving system block diagram	2-24
2-16	Local oscillator V902, cutaway view	2-25
2-17	Local oscillator V902, simplified schematic diagram	2-26
2-18	Balanced signal mixer, functional schematic diagram -	2-27
2-19	Afc system block diagram ---	2-31
2-20	Afc discriminator output pulse	2-32
2-21	Afc discriminator response	2-33
2-22	Delay line DL701, functional schematic diagram	2-36
2-23	Ranging system, block diagram	2-38
2-24	Zener diode characteristic curve	2-40
2-25	Constant current generator Q403, characteristic curve	2-40
2-26	Long strobe mode, simplified schematic diagram -	2-43
2-27	Short strobe mode, simplified schematic diagram - _	2-44
2-28	Discharge path of capacitors C1001 and C1003 -	2-45
2-29	Normal mode, simplified schematic diagram -	2-45
2-30	Audio system, block diagram - _	2-49
2-31	Automatic gain control system block diagram -	2-51
2-32	Automatic gain control system, simplified schematic diagram	2-53
2-33	Power converter system, block diagram	2-55
2-34	Control circuit power distribution, simplified schematic diagram	2-57
2-35	BATTERY TEST switch, simplified schematic diagram.....	2-61
	controls, simplified schematic diagram	2-42
2-36	RANGE CONTROL handwheel and RANGE CALIBRATION	
2-37	HEADSET receptacles, simplified schematic diagram	2-62
2-38	RANGE METERS indicator, mechanical diagram	2-64
3-1	Receiver-transmitter, center section, front side	3-6
3-2	Four-layer diode tester	3-7
3-3	IF amplifier unit alignment cover -	3-10
3-4	Dummy mixer, schematic diagram	3-10
3-5	Control panel support fixture	3-11
3-6	Coaxial cable BNC to clip leads - -	3-12
3-7	Terminated test cable	3-12
3-8	Strobe unit on rear of control panel	3-16
3-9	Receiver-transmitter center section, rear side - _	3-17
3-10	Waveforms for troubleshooting based on starting procedures -	3-20
3-11	Transmitting system waveforms	3-20
3-12	Transmitter unit, cover attached	3-21
3-13	Receiver-transmitter, rear side, panel removed	3-24
3-14	Transmitter unit removed from chassis	3-25
3-15	IF amplifier unit circuit board, capacitors and diodes	3-26
3-16	IF amplifier unit circuit board, inductors, resistors, and transistors	3-27
3-17	IF amplifier unit circuit board, inductors and resistors	3-28
3-18	IF amplifier unit circuit board, rear view, capacitors	3-29
3-19	Waveform, transmitter pulse and receiver noise	3-30
3-20	Waveform, rangemarks	3-30
3-21	Afc unit, capacitors, diodes, and transistors -	3-30
3-22	Afc unit, resistors and inductors _	3-31
3-23	Audio unit, capacitors, diodes, transistors, and jacks	3-31
3-24	Audio unit, resistors -	3-33
3-25	Afc unit, location of internal test paints -	3-33
3-26	Audio unit, location of internal test points	3-33
3-27	Afc system error pulse	3-33
3-28	Afc sweep voltage 3-35	
3-29	Amplified afc sweep voltage	3-35
3-30	Afc unit waveforms	3-38

3-31	Rear of control panel, strobe unit removed	3-39
3-32	Range unit, resistors, transistors, and jacks	3-42
3-33	Range unit, diodes, capacitors, and transformers	3-42
3-34	Strobe unit	3-43
3-45	Normal indication at ranging system test jacks	3-48
3-36	Range unit, location of internal test points	3-49
3-37	Abnormal indications at range unit jack J4	3-49
3-38	Multiar pulse	3-49
3-39	Sweep at E415	3-49
3-40	Square wave at E433	3-49
3-41	Audio unit waveforms	3-51
3-42	Power converter unit, heat dissipation plate removed	3-52
3-43	Dial assembly, partial exploded view	3-53
3-44	Bandwidth and gain adjustment test equipment setup	3-58
3-45	Ideal response curves for bandwidth and gain adjustment	3-60
3-46	Typical response covers for bandwidth and gain adjustment	3-61
	dummy mixer in place	3-62
3-47	Bandwidth and gain adjustment, test equipment setup,	
3-48	Afc unit alignment test setup	3-65
3-49	Afc discriminator response	3-46
3-50	Position of spectrum analyzer pickup horn for afc adjustment	3-67
3-51	Frequency spectrum display	3-72
3-52	Deviation versus signal generator rangemarks	3-72
3-53	Overlay used in plotting straight line	3-72
3-54	Positioning overlay	3-72
3-55	Range unit, cover attached	3-75
3-56	IF amplifier unit, top view	3-76
3-57	IF amplifier unit, bottom view	3-76
3-58	Audio unit, cover attached	3-76
3-59	Afc unit, cover attached	3-77
3-60	Receiver transmitter, rear side, units removed	3-77
3-61	Power converter unit	3-78
3-62	Receiver transmitter, front side, radome removed	3-79
3-63	Receiver-transmitter center section, microwave assembly in place	3-80
3-64	Crystal jacks and jack J701 exposed	3-81
	locknut exposed	3-82
3-65	Capacitor C6 socket removed and adjustment screw with	
3-66	Position of 3/8inch box wrench and screwdriver	3-83
3-67	Center section with microwave assembly removed	3-84
	microwave assembly removed	3-85
3-68	Receiver transmitter, center section, front side,	
3-69	Magnetron V901, knurled tuning knob assembled	3-86
3-70	Correct position for magnetron V901 knurled tuning knob	3-87
3-71	RF system, exploded view	3-88
3-72	Radome guide flange exposed	3-89
3-73	Bracket assembly showing insulation sleeve	3-90
3-74	RF system with klystron, magnetron, and crystals attached	3-91
3-75	Right and wrong way to mate feed assembly	3-92
3-76	Magnetron V901	3-92
3-77	Location of klystron V902 plastic clamp and socket	3-93
3-78	Placement of screwdriver	3-94
3-79	Waveguide in flexed position	3-95
5-1	Tripod leg assembly, exploded view	5-26
5-2	Tripod head assembly, exploded view	5-28
5-3	Positioning of tripod legs	5-31
5-4	Positioning of azimuth lock assembly	5-33
7-1	Test setup	7-3
7-2	Color code markings for MILSTD resistors	7-8
7-3	Color code markings for MIISTD capacitors	7-9
7-4	Radar Set AN/PPS4A, system function block diagram	7-11
7-5	Radar Set AN/PPS4A, complete block diagram	7-13
7-6	Transmitter unit, complete schematic diagram	7-15
7-7	IF amplifier unit, complete schematic diagram	7-17
7-8	Afc unit, complete schematic diagram	7-19
7-9	Range unit, complete schematic diagram	7-21

7-10 Strobe unit, complete schematic diagram7-23
7-11 Audio unit, complete schematic diagram7-25
7-12 Power converter, complete schematic diagram7-27
7-13 Control panel, complete schematic diagram7-29
7-14 Interconnection diagram7-31

CHAPTER 1

INTRODUCTION

1-1. Scope

a. This manual covers direct support, general support, and depot maintenance procedures for Radar Set AN/PPS-4A (including Radar Set AN-PPS-4 modified by MWO 11-5840-211-1). It includes functioning of the equipment, block diagram discussions, and system theory (chap 2); direct support troubleshooting, adjustment and alignment, repair, and removal and replacement (chap 3); direct support testing procedures (chap 4); general support troubleshooting, repair, removal and replacement, and disassembly and reassembly of tripod (chap. 5); depot maintenance (chap 6); and depot overhaul standards (chap 7).

b. Operating instructions and organizational maintenance procedures are contained in TM 115840-211-12.

1-2. Indexes of Publications

a. DA Pam 310-4. Refer to the latest issue of DA Pam 310-4 to determine whether there are new editions, changes, or additional publications pertaining to the equipment.

b. DA Pam 310-7. Refer to DA Pam 310-7 to determine whether there are modification work orders (MWO's) pertaining to the equipment.

1-2.1 Maintenance Forms, Records, and Reports

a. Reports of Maintenance and Unsatisfactory Equipment. Department of the Army forms and procedures used for equipment maintenance will be those described by TM 38-750, The Army Maintenance Management System.

b. Report of Packaging and Handling Deficiencies. Fill out and forward DD Form 6 (Packaging Improvement Report) as prescribed in AR 70058/NAVSUPINST 4030.29/AFR 71-13/MCO P4030.29A, and DLAR 4145.8.

c. Discrepancy in Shipment Report (DISREP) (SF 361). Fill out and forward Discrepancy in Shipment Report (DISREP) (SF 361) as prescribed in AR 55-38/NAVSUPINST 4610.33B/ AFR 75-18/MCO P4610.19C, and DLAR 4500.15.

1-3. Reporting Errors and Recommending Improvements

You can help improve this manual. If you find any mistakes or if you know of a way to improve the procedures, please let us know. Mail your letter, DA Form 2028 (Recommended Changes to Publications and Blank Forms), direct to: Commander, US Army Communications and Electronics Materiel Command and Fort Monmouth, ATTN: DRSELME-MQ, Fort Monmouth, NJ 07703. A reply will be furnished direct to you.

1-4. Reporting Equipment Improvement Recommendations (EIR)

If your Radar Set AN/PPS-4A needs improvement, let us know. Send us an EIR. You, the user, are the only one who can tell us what you don't like about your equipment. Let us know why you don't like the design. Tell us why a procedure is hard to perform. Put it on an SF 368 (Quality Deficiency Report). Mail it to Commander, US Army Communications and Electronics Materiel Readiness Command and Fort Monmouth, ATTN: DRSEL-ME-MQ, Fort Monmouth, NJ 07703. A reply will be furnished direct to you.

CHAPTER 2

FUNCTIONING OF EQUIPMENT

Section I. System Function

2-1. Groupings of Components

The general functioning of Radar Set AN/PPS4A can be explained best by dividing the set into nine systems, each of which performs one or more specific functions. The function of each system and the relationship between these systems and the overall radar set are shown in the system functional block diagram (fig. 7-4), and explained in further detail in paragraphs 2-2 through 2-10. The components of the radar set are grouped into systems as follows:

- a. Transmitting system.
- b. RF system.
- c. Receiving system.
- d. Automatic frequency control (afc) system.
- e. Ranging system.
- f. Audio system.
- g. Automatic gain control (agc) system.
- h. Power converter system.
- i. Control system.

2-2. Transmitting System

a. The transmitting system (fig. 7-4) performs the following functions:

- (1) Generates the radiofrequency (RF) pulse which is applied to the RF system for radiation into space.
- (2) Generates the negative blanking pulse which is sent to the receiving system to blank the receiving system signal intermediate frequency (IF) amplifiers during the transmitted pulse interval.
- (3) Generates the negative gate which is used to start the linear sweep in the ranging system.
- (4) Receives from the ranging system the multiar pulse whose negative overshoot terminates the negative gate.

b. The RF pulse has a peak power of 0.5 kilowatt and is transmitted at a frequency between 8,900 and 9,400 megahertz (MHz). The pulse width of the RF pulse is 0.2 microsecond and the

pulse repetition frequency is approximately 3,000 pulses per second (pps).

c. The transmitting system consists of the components in the transmitter unit and magnetron V901.

2-3. RF System

a. The RF system (fig. 7-4) performs the following functions:

- (1) Radiates, in a narrow beam, the RF pulse generated by the transmitting system.
- (2) Receives the target echo pulse which is fed to the receiving system.
- (3) Attenuates and couples a magnetron pulse to the afc system for mixing with the local oscillator signal.

b. The RF system contains a duplexer which prevents high-power magnetron pulses from damaging the components of the receiving system during transmit time, but permits the target echo to pass to the receiving system during the time the transmitter is not transmitting.

c. The RF system consists of a microwave assembly and a parabolic reflector.

2-4. Receiving System

a. The receiving system (fig. 7-4):

- (1) Generates the local oscillator signal.

(2) Mixes the target echo pulse with the local oscillator signal to develop IF signals of 30 MHz.

(3) Amplifies the IF signals.

(4) Detects the amplified IF signals to produce video signals which are amplified and sent to the ranging system.

(5) Receives, amplifies, and detects 30-MHz rangemarks from the afc system when POWER switch S101 is in the RANGE position.

(6) Receives from the agc system the agc voltage which controls the overall gain of the receiving system.

b. The receiving system consists of klystron local oscillator V902, signal mixer crystals CR901 and CR902, and the components in the IF amplifier unit.

2-5. Automatic Frequency Control System

a. The automatic frequency control system (fig. 7-4) performs the following functions: (1) ,Receives an attenuated magnetron pulse from the RF system.

(2) Mixes this pulse with the local oscillator signal from the receiving system.

(3) Develops a direct current (dc) voltage which controls the frequency of the local oscillator so that the IF signal is maintained at 30 MHz.

(4) Generates precision rangemarks which are used for range calibration of the ranging system.

b. The afc system consists of afc mixer crystal CR903, the components in the afc unit, and the afc search and control circuit contained in the audio unit.

2-6. Ranging System

a. The ranging system (fig. 7-4) performs the following functions: (1) Receives from the transmitting system the negative gate which starts a linear sweep.

(2) Receives the video signal from the receiving system.

(3) Generates and sends to the audio and age systems a boxcar detector voltage whose amplitude is dependent upon the position of the range gate and the nature of the target being gated.

(4) Receives from the age system the age voltage which is converted and displayed on the RANGE EXTENSION METERS meter.

(5) Provides current to deflect the RANGE EXTENSION METERS meter according to the mode of operation.

(6) Generates a multiar pulse which terminates the negative gate from the transmitting system.

(7) Receives from the control system the range voltage which determines the range of the detected target.

b. The ranging system is composed of the components in the range unit and the strobe unit.

2-7. Audio System

a. The audio system (fig. 7-4) filters and amplifies the boxcar detector voltage from the ranging system and produces an audio signal which 2-2 can be detected in the headsets as a sound indicative of a moving target.

b. The audio system is comprised of the audio unit, audio transformer T1, audio filter FL3, and RF filters FL103 and FL104.

2-8. Automatic Gain Control System

a. The automatic gain control system (fig. 74) performs the following functions: (1) Receives the boxcar detector voltage from the ranging system.

(2) Develops an age voltage which controls the gain of the signal IF amplifiers in the receiving system.

(3) Provides current to deflect the needle of the RANGE EXTENSION METERS meter when targets are detected.

b. The agc system is composed of two transistor stages located in the audio unit and potentiometer R105.

2-9. Power Converter System

a. The power converter system (fig. 7-4) performs the following functions: (1) Receives a positive dc voltage (+22.5 to +27.15) from an external power source.

(2) Converts the de input voltage to a square wave; steps the voltage up or down, as necessary, by transformer action; rectifies and filters part of the secondary output to obtain the de voltages for use in the radar set.

(3) Provides the following dc voltages to other functional systems in the radar set: +270, +250, +120, +24, -20, -150, and root mean square voltages 6.3, 7.0, and 2.7.

b. The power converter system is composed of the power converter unit, capacitor C6, and reactor L1.

2-10. Control System

a. The control system (fig. 7-4) provides a means of—

- (1) Turning the radar set on and off.
- (2) Protecting the circuits in the radar set.
- (3) Selecting the modes. of operation.
- (4) Visually and aurally indicating detected targets.
- (5) Indicating the range of the detected targets
- (6) Visually indicating the position of the rangemarks and calibrating the ranging system.
- (7) Connecting an external power source to the radar set.

(8) Adjusting the voltage output of the power converter system.

(9) Testing the condition of battery charge when a battery is used as the external power source.

(10) Turning on and off, and adjusting intensity of the lamps in the radar set.

(11) Adjusting the volume of the aural indication of detected targets.

(12) Selecting the strobe mode of operation.

b. The control system is composed basically of RANGE EXTENSION METERS meter M101, variable resistors R101, R102, R104 and R106; switches S101, S102, S103, S104, S105, S106, and S107; fuses F101 and F102; and receptacles J102, J103, and J104.

Section II. COMPLETE BLOCK DIAGRAM

2-11. Purpose of Complete Block Diagram

The complete block diagram of Radar Set AN/APS-4A (fig. 7-5) can be used as a quick review of the basic functioning of the equipment by a radar repairman. The diagram also enables a repairman who is familiar with radar principles, but who is not acquainted with this particular set, to gain a basic understanding of the units and stages in the equipment. When troubleshooting, the block diagram is valuable because it enables the repairman to narrow down troubles to a particular stage within the equipment. This type of troubleshooting is important because it eliminates a considerable amount of operating time loss that results when the equipment has to be shut down to await a higher category of maintenance.

2-12. Timing

a. When the radar set is turned on (POWER switch at TRANSMIT), power is applied after a 90-second time-delay to the circuits in the set.

b. Unijunction transistor Q204 generates a pretrigger (retrigger circuit) approximately 5 microseconds prior to generation of the transmitted RF pulse in the transmitting system (fig. 7-5). These pretriggers are produced at the rate of approximately 3,000 pulses per second. The trailing edge of this pretrigger pulse produces a zero time trigger which causes silicon controlled rectifier SCR202 to conduct through the pulseforming circuit to produce a -4.5-kilovolt (kv) pulse. The 4.5-kv output from the pulseforming circuit drives magnetron V901. The pulseforming circuit also produces a negative gate to trigger the ranging system, and a blanking pulse to prevent saturation of the signal IF amplifiers in the receiving system during the time of the transmitted pulse.

c. The important pulses and waveforms used in timing the radar set are shown in figure 2-1 and discussed in (1) through (9) below.

(1) The trailing edge of the pretrigger pulse serves to generate the -4.5-kv pulse from the pulse-forming circuit in the transmitting system, causing the magnetron to produce a pulse of RF energy that has a duration of approximately 0.2 microsecond (B, fig. 2-1).

(2) The negative gate (C, fig. 2-1) triggers the linear sweep circuit in the ranging system.

(3) The blanking pulse (D, fig. 2-1) blanks the IF amplifiers in the receiving system during the transmitted pulse interval to prevent saturation due to excessive transmitted pulse leakage.

(4) The duration of the sweep from the linear sweep circuit in the ranging system varies from 0 to 53.3 microseconds (E, fig. 2-1), and depends upon the position of the range gate.

(5) The sweep from the linear sweep circuit triggers the multiar in the comparator circuit of the ranging system to produce a 1.8microsecond pulse (F, fig. 2-1). This pulse, in turn, triggers the blocking oscillator in the range gate circuit of the ranging system. The overshoot of the multiar pulse triggers the negative gate discharge circuit to terminate the negative gate and linear sweep.

(6) The blocking oscillator produces a range gate of 0.2-microsecond duration (G, fig. 2-1) and applies the range gate to the boxcar detector in the ranging system.

(7) Target echo pulses pass through the mixer and signal circuits of the receiving system and are amplified and converted into video signals (H, fig. 2-1).

(8) The video signals, coincident with the range gate, are gated and detected by the boxcar detector in the ranging system. When the return is from a fixed target, the video signals have a constant amplitude; thus, the boxcar detector voltage is essentially of a constant amplitude. In this case, the signal fed to the audio system is a steady dc voltage, and no

audio signals will be heard in the headsets. When the return is from a moving target, the video signals will vary in amplitude and will produce the boxcar detector voltage shown in I, figure 2-1. When this voltage is fed to the audio system, it is filtered and amplified to produce audio signals (K, fig. 2-1) which can be heard in the headsets.

(9) Moving targets in the presence of ground clutter at the same range will produce an audio signal in the headsets. Fixed targets and moving targets separated by range or azimuth bearing will not produce an audio signal in the headsets, but will provide a visual indication by causing the needle of the RANGE EXTENSION METERS meter to deflect to the left to a minimum value.

2-13. Complete Block Diagram Discussion

Functionally, Radar Set AN/PPS-4A is divided into nine systems: transmitting, RF, receiving, automatic frequency control, ranging, audio, automatic gain control, power converter, and control. Each system in the block diagram is inclosed in a block made of a solid line. Groupings of stages that act together as a complete circuit are inclosed in blocks made of broken lines. Signal paths are shown on the diagram by solid lines with arrowheads; mechanical connections are shown by dashed lines; waveguides are shown by double lines. The separate systems are discussed in a through i below.

a. Transmitting System.

(1) Thermal delay circuit. The thermal delay circuit consists of thermal delay relay K201 and relay K202. Approximately 90 seconds after the POWER switch is set at STANDBY, TRANSMIT, or RANGE, thermal relay K201 will actuate and energize relay K202. The +24 volts is applied through the control system through energized relay K202 to the pretrigger circuit if the POWER switch is set at TRANSMIT or RANGE.

(2) Pretrigger circuits. The pretrigger circuit produces a negative pulse at approximately 3,000 pps. The trailing edge of this pulse turns on silicon controlled rectifier SCR202, in the pulse-forming circuit. The amplitude of this pulse at the silicon controlled rectifier (SCR202) gate is 4 volts, and the duration is 0.4 microseconds.

(3) Pulseforming circuit. The pulse-forming circuit consists of silicon controlled rectifier SCR202, a charging choke, pulse-forming line, and a pulse transformer (components of pulse unit Z201). The pulse-forming line is charged from the +270-volt line through the charging choke. Each time SCR202 is triggered, the pulse

forming line discharges through a bifilar-wound pulse transformer which, in turn, develops a negative pulse that drives magnetron V901 once every 330 microseconds, develops a negative 60volt pulse which is applied to negative gate circuit C205 and CR205 in the transmitting system, and applies a negative 60-volt pulse as a negative blanking pulse to the receiving system where it blanks the signal IF amplifiers during the transmitted pulse interval and thus prevents the amplifiers from becoming saturated.

(4) Magnetron V901. When the magnetron V901 is pulsed, it generates 0.2-microsecond pulses of RF energy that are radiated into space by the antenna system. These RF pulses have a peak power of 0.5 kilowatt and a frequency between 8,900 and 9,400 MHz.

(5) Magnetron current filter C203 and R205. Magnetron current filter C203 and R205 attenuates the 3,000-pps variation from the magnetron current to permit measurement of a voltage at test jacks J204 and J205, which is proportional to the magnetron current.

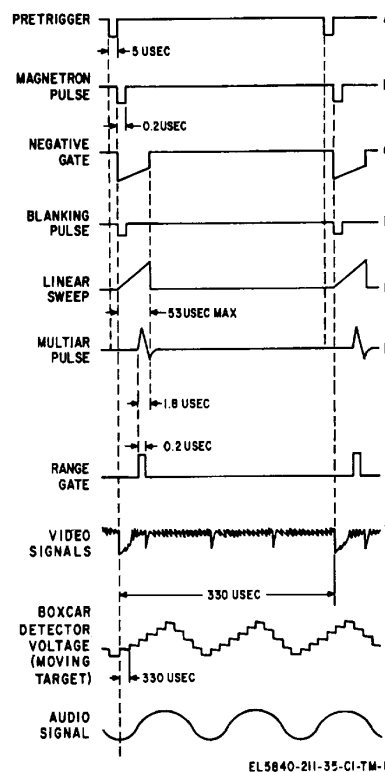

Figure 2-1. Basic timing circuit.

(6) Negative gate circuit C205 and CR205 and negative gate discharge circuit Q201 and CR206. The negative 60-volt pulse from the pulse transformer charges capacitor C205 in the negative gate circuit through diode CR205, and thus generates the negative gate which is applied to the linear sweep circuit in the ranging system. When the negative overshoot of the multiar pulse from the ranging system reaches the negative gate discharge circuit, it passes through diode OR206 and turns on transistor Q201, driving Q201 to saturation. This, in turn, allows capacitor C205 to discharge through transistor Q201 and terminates the negative gate.

b. Rf System.

(1) Balanced duplexer. The balanced duplexer (consisting of dual-channel limiter V903 and two short slot hybrid couplers which are integral portions of hybrid waveguide assemblies No. 1 and 2) acts as a switch to prevent highpower RF energy from entering the receiving system during transmission, and to allow the target echo pulses to enter the receiving system during reception.

(2) Afc coupler. The afc coupler provides an attenuated sample of the magnetron output energy for use in the afc system.

(3) Directional coupler. The directional coupler provides an attenuated sample of magnetron output energy to permit measurement of magnetron output power and frequency by means of external test equipment.

(4) Antenna. The antenna consists of two dipoles mounted on the antenna feed assembly and a parabolic reflector. The RF energy from magnetron V901 is radiated from the dipoles toward the parabolic reflector which focuses the RF energy into a narrow beam. Target echo pulses are collected by the reflector, focused towards the two dipoles and routed through the microwave assembly to the receiving system.

c. Receiving System.

(1) Frequency converter. The frequency converter, consisting of klystron local oscillator V902 and balanced signal mixer (CR901 and CR902) produces a 30-MHz IF signal by mixing received target echo pulses with a continuous RF signal provided by klystron local oscillator V902. The 30-MHz IF signal is fed to the signal IF amplifier and detector circuits.

(2) Signal IF amplifier and detector. The signal IF amplifier and detector consists of a double-tuned input network; signal IF preamplifier Q508; signal IF amplifiers Q501, Q502, Q506, Q504, and video detector CR501. If POWER switch S101 is set to TRANSMIT, the signal

IF amplifier and detector amplifies and detects the 30-MHz IF signals from the frequency converter and feeds the resulting video signals to the video amplifier circuits. If POWER switch S101 is set to RANGE, the +24-volt supply is disconnected from the emitter of signal IF preamplifier Q508, preventing the 30-MHz IF signals from the frequency converter from entering the signal IF amplifiers. Instead 30-MHz rangemarks from the afc system are applied to the input of signal IF amplifier Q501; are amplified by Q501, Q502, Q503, Q504, and Q505; and detected by video detector CR501. These rangemarks provide a means of range-calibrating the ranging system.

(3) Video amplifier. The video amplifier, consisting of amplifier Q506 and emitter follower output stage Q507, amplifies the video signals from the signal IF amplifier and detector, and feeds them as a video signal to the boxcar detector circuit in the ranging system.

(4) Blanking and limiting circuit. The blanking and limiting circuit receives the negative blanking pulse from the transmitting system and applies a portion of this pulse to signal IF amplifiers Q501, Q502, and Q503. The negative blanking pulse disables these amplifiers during the transmitted pulse interval, thus preventing saturation and generation of noise due to leakage of the transmitted pulse. This noise otherwise would be amplified by the signal IF amplifiers and heard in the headsets.

d. Automatic Frequency Control System.

(1) Afc mixer. Afc mixer CR903 mixes the signal from klystron local oscillator V902 with the attenuated magnetron pulses from the age coupler in the RF system to produce a pulsed IF signal which is applied to the afc IF amplifiers.

(2) Afc IF amplifiers. Afc IF amplifiers Q701 and Q702 amplify the pulsed IF signal from the afc mixer and feed the amplified signal to the precision rangemark generating circuit and to the afc discriminator.

(3) Afc discriminator. The afc discriminator CR701, CR702, CR704, and CR705 samples the IF signal from the afc IF amplifiers and produces a pulse error signal whose amplitude is a function of the frequency of the IF input signal. The afc discriminator produces a zero output for input signals of approximately 29 MHz; positive video pulses for input signals below 29 MHz; and negative video pulses for signals above 29 MHz.

(4) Afc video amplifier circuit. The afc video amplifier circuit, consisting of emitter follower Q706 and amplifiers Q704 and Q705, amplifies only the negative video pulses (corresponding to an intermediate frequency above 29

MHz) from the afc discriminator and feeds them to the afc search and control circuit.

(5) Afc search and control circuit. The afc search and control circuit consists of detector circuits C708, CR603, and R625, amplifiers Q607 and Q606, and relaxation oscillator Q608. When no signals are applied to the detector circuit, the afc search and control circuit produces a sweep voltage on the reflector of klystron local oscillator V902 which sweeps the klystron frequency approximately five times each second. When negative video pulses from the afc video amplifier circuit enter the afc search and control circuit, the sweeping action is stopped and the pulses are converted into a negative dc voltage which is amplified, and coupled to the reflector of local oscillator V902 to adjust the local oscillator frequency, and thus maintain the IF frequency at 30 MHz.

(6) Precision rangemark generating circuit. The precision rangemark generating circuit is composed of delay line DL701 and relay K701. This circuit receives the amplified IF signal from the afc IF amplifiers and produces a series of accurately spaced 30-MHz pulses (fig 2-22). These pulses are applied to the receiving system when the POWER switch is set at RANGE and are used as rangemarks for calibration of the ranging system.

e. Ranging System.

(1) Linear sweep circuit. The linear sweep circuit consists of linear sweep switch Q401 and linear sweep generators Q402 and Q403. The negative gate from the transmitting system causes linear sweep switch Q401 to energize linear sweep generators Q402 and Q403. The linear sweep generator produces a linear sweep whose length varies from 0 to 53 microseconds depending upon the length of the negative gate. The linear sweep is fed to pickoff circuit C406 and OR411 in the comparator circuit.

(2) Strobe circuit. The strobe circuit, composed of relaxation oscillator CR1002, double emitter followers Q1001 and Q1002, and a voltage divider, produces a sweep of 10 or 5-second duration, or a constant dc voltage depending upon the setting of STROBE switch S105 in the control system. The strobe circuit provides for automatic scanning of the range by allowing the range gate to strobe through 500 meters beyond the setting of the RANGE METERS indicator when STROBE switch S105 is in the LONG (10 seconds) or SHORT (6 seconds) position. The output of the strobe circuit is fed to the comparator circuit, and is also used to deflect the needle on the RANGE EXTENSION METERS meter in the control system.

(3) Comparator circuit. The comparator circuit consists of pickoff circuits C406 and CR411, and multipliers Q404 and T401. When the voltage of the linear sweep rises to a voltage greater than the range voltage applied to diode CR411 from range potentiometer R103 (adjusted by the 'RANGE CONTROL handwheel), diode CR411 will conduct and cause multipliers Q404 and T401 to develop a multiplier pulse which is fed to the range gate circuit. A portion of the multiplier pulse is fed to the negative gate discharge circuit in the transmitting system.

(4) Range gate circuit. The range gate circuit is composed of differentiating circuits C410 and R416, and blocking oscillators Q405 and T402. Differentiating circuits C410 and R416 differentiate the multiplier pulse to produce a positive pulse that triggers blocking oscillators Q406 and T402. Blocking oscillators Q405 and T402 produce a 10-volt, 0.2-microsecond range gate which is coupled to the detector circuit.

(5) Detector circuit. The detector circuit, composed of boxcar detectors CR413, CR414, and R424 and double emitter followers Q406 and Q4017, gates, detects, and "stretches" the video signals that are supplied by the receiving system. The boxcar detector voltage is fed to the audio and age systems through double emitter followers Q406 and Q407.

f. Audio System.

(1) Audio amplifier circuit. Low-pass filters R601 and C602 remove the period-to-period steps of the incoming boxcar detector voltage from the ranging system and provide a relatively smooth audio output to amplifier Q601. Amplifier Q601 amplifies the audio signal from the low-pass filter and feeds it through audio filter FIL3 and amplifier Q609 to push-pull emitter followers Q602 and Q603. A portion of the signal from audio filter FL6 is fed back through limiting circuits OR601, CR606, R606, R607, and C606 to amplifier Q601 to prevent overdriving of the successive amplifier stages with large input signals. The output of push-pull emitter followers Q602 and Q603 is fed to audio transformer T1.

(2) Audio transformer and RF filters. Audio transformer T1 is used to couple the audio signal through RF filters FL103 and FL104 to HEADSET receptacles J102 and J103 in the control system.

g. Age System.

(1) Diode CR602. Before the boxcar detector voltage from the ranging system enters the age system, diode CR602 is not conducting appreciable current. When the boxcar detector voltage enters the age system, diode CR602 conducts

an amount of current proportional to the amplitude of the input signal and sends a negative voltage to amplifier Q604.

(2) Amplifier QC04. When the negative voltage from diode CR602 is applied to amplifier Q604, the current in amplifier Q604 increases and causes a decrease in the voltage drop across filters R619 and C60;1. This filter delays the agc action. The output voltage across capacitor C607 is fed to emitter follower Q605.

(3) Emitter follower Q605. Before the boxcar detector voltage enters the age system, the output of emitter follower Q605 is an age voltage of approximately -3.5 volts. When the output across filter capacitor C607 decreases, the age output voltage of emitter follower Q605 decreases. The age voltage is fed to the receiving system to control the gain of the signal IF amplifiers, and to the strobe circuit in the ranging system to indicate the presence of targets. As the age voltage becomes more negative, the gain of the receiving system increases. When no targets are being gated, the agc voltage output of emitter follower Q605 is determined by the agc voltage level picked off VOLUME control R105 in the control system.

h. Power Converter System.

(1) Flip-flop circuit. A flip-flop circuit, consisting of multivibrators Q801 and Q802, transformers T801 and T802, and switch S102 is used to convert the dc input voltage to ac in order that the transformer may change the input voltage to the various voltages required throughout the system. The circuit receives its energizing voltage through the control system from an external power source, and produces a square-wave output on the secondaries of transformer T801. Switch S102 is used to select the taps on the primary of T801, thereby allowing the radar to operate over an input voltage range of +22.5 to +27.5 volts. Three secondary windings of transformer T801 produce square waves of 7, 6.3, and 2.7 volts rms amplitude to supply the filaments and lamps of the radar set. The outputs from the remainder of the secondary windings of transformer T801 are rectified and filtered.

(2) Rectifier and filter circuit. The square wave outputs of the secondary transformer T801 are rectified by diodes and filtered by capacitors. The dc outputs of these circuits are

- (a) + 270 volts to the transmitting system.
- (b) +250 volts to the receiving system.
- (c) -150 volts to the afc system.
- (d) +120 volts to the ranging system.

(e) +24 volts to the ranging, receiving, audio, afc, and age systems.

(f) -20 volts to the ranging, receiving, audio, age, and afc systems.

i. Control System

(1) POWER switch. The 24-volt dc output from the external power source is applied through 24 VDC BAT ONLY receptacle J104, low-pass filters FL101 and FL102, protective diode CR101, to POWER FUSE F102 and to POWER switch S101. Diode CR101 protects the equipment against incorrect connection of the battery leads. If the POWER SWITCH is set to any position except OFF, the 24-volt dc power will be applied through interlock switch S1 to the power converter system and to thermal relay K201 in the transmitting system. In the TRANSMIT and RANGE positions, +270 volts from the power converter system is applied through XMTR fuse F101 to the transmitting system. In addition, if the POWER switch is set to RANGE, +24 volts will be applied to relay K701 in the afc system to switch the precision rangemarks into the receiving system and remove the +24 volts from the emitter of signal IF preamplifier in the receiving system.

(2) VOLTAGE ADJ switch. VOLTAGE ADJ switch S102 compensates for input voltage variations of the external power source by varying the primary-to-secondary turns ratio of transformer T801 in the power converter system.

(3) STROBE switch. The ranging system mode of operation, either short, long, or normal, is determined by the position of STROBE switch S105. This switch provides for the application of a 5 or 10-second sweep or a constant dc voltage to the strobe circuit in the ranging system.

(4) RANGE EXTENSION METERS meter. Agc voltage, and strobe and range calibration signals are indicated on RANGE EXTENSION METERS meter M101. When BATTERY TEST button S104 is depressed, the +24-volt output of the power converter system is applied across voltage dividers CR1002, R1005, and R1006 and is measured by meter M101 to determine the proper position of the VOLTAGE ADJ switch.

(5) RANGE CONTROL handwheel. Rotation of the RANGE CONTROL handwheel varies the wiper arm of potentiometer R103 and thus varies the range voltage supplied to the ranging system for manual positioning of the range gate. The position of the range gate is indicated by the RANGE METERS indicator. RANGE CALIBRATION 1st MARK variable resistor R101 and RANGE CALIBRATION 7th

MARK variable resistor R102, connected in series with potentiometer R103, provide adjustments for accurate calibration of the range gate position.

(6) VOLUME control. VOLUME control R105 functions as a voltage divider to furnish a steady dc voltage (agc voltage level) to the age system and thus control the gain of the receiving system.

(7) TELESCOPE LIGHT, TRIPOD LIGHTS, and PANEL LIGHTS switches.

TELESCOPE LIGHT switch S103 connects 2.7-volt ac power to the telescope lamp. TRIPOD LIGHTS SWITCH S106 and PANEL LIGHTS switch S107 connect 2.7-volt ac power to the tripod and panel lamps, respectively; variable resistors R106 and R104 vary the intensity of these lamps.

(8) HEADSET receptacles. HEADSET receptacles J102 and J103 couple the audio signal from the audio system to the headsets.

Section III. TRANSMITTING SYSTEM FUNCTION

2-14. General

a. The transmitting system produces pulses of RF energy at fixed intervals. The RF detected pulse width (pw) is 0.2 +0.02 microsecond and the prf is approximately 3,000 pps. The frequency of the RF output is from 8,900 to 9,400 MHz. The nominal peak power output is 0.5 kilowatt (kw), and the average power is 0.3 watt. The transmitting system also produces a negative blanking pulse for the receiving system and a negative gate which triggers the linear sweep circuit in the ranging system. A negative gate discharge circuit is provided to terminate the negative gate immediately after the range gate is triggered.

b. The relationship of the transmitting system with respect to other functional systems of the radar set is covered in paragraph 2-13.

2-15. System Block Diagram Discussion

(Fig. 2-2.)

a. Thermal Delay Circuit. The thermal delay circuit consists of thermal delay relay K201 and relay K202. The thermal delay circuit delays the * application of +24 volts to the prf generator for approximately 90 seconds in order to allow the tube filaments of the radar set to heat. When POWER switch S101 is placed in the STANDBY, TRANSMIT, or RANGE position, +24 volts is applied to the heating element of thermal delay relay K201, and the ac filament voltages are supplied to the vacuum tubes in the radar set. Approximately 90 seconds after the POWER switch has been placed in one of the positions specified above, relay K201 closes, and relay K202 is then operated by +24 volts. The operated relay K202 allows +24 volts from the power * converter system to be applied to the prf generator via POWER switch S101. Relay K202 is a self-holding relay and allows relay K201 to restore.

b. Modulator. The modulator is composed of a pretrigger Unijunction transistor Q204 generator, blocking oscillator consisting of transistor Q205 and pulse transformer T202, and SCR driver Q206, and SCR202. The repetition rate of the trigger is 3,000 pps. The blocking oscillator provides a 4.0-volt, 0.4-microsecond pulse to turn on silicon controlled rectifier SCR202.

c. Pulse-Forming Circuit. The pulse-forming circuit consists of pulse unit Z201. Pulse unit Z201 consists of a charging choke, a pulseforming network (pan), and a pulse transformer. Positive 270 volts is applied to the charging choke of pulse unit Z201, and the capacitors in the pulse-forming line charge to approximately 540 volts. The 4-volt pulse from the modulator blocking oscillator (zero time pulse) is applied to the gate of silicon controlled rectifier SCR202 and triggers the silicon controlled rectifier into conduction. When the silicon controlled rectifier conducts, the pulse-forming line discharges through the rectifier and the primary of the pulse transformer of pulse unit Z201. Jack J203 serves as a test point at the anode of SCR202. The 4.5-kv output of the secondary of the pulse transformer is applied to the cathode of magnetron V901.

d. Magnetron Current Filter. The pulse transformer also provides an output to magnetron current filter C218 and R220 which partially removes the 5,000-pps variation. This average magnetron current is provided for measurement at test point jacks J204 and J205 as a voltage across 1,000-ohm resistor R220. Therefore, 1 volt dc across resistor R220 corresponds to 1 milliamper (ma) of magnetron current.

e. Negative Gate Circuit. A negative 60-volt pulse developed across winding 4-11 (not shown) of the pulse transformer charges capacitor C205 through diode CR205 and resistor R210 to generate the negative gate, which triggers the

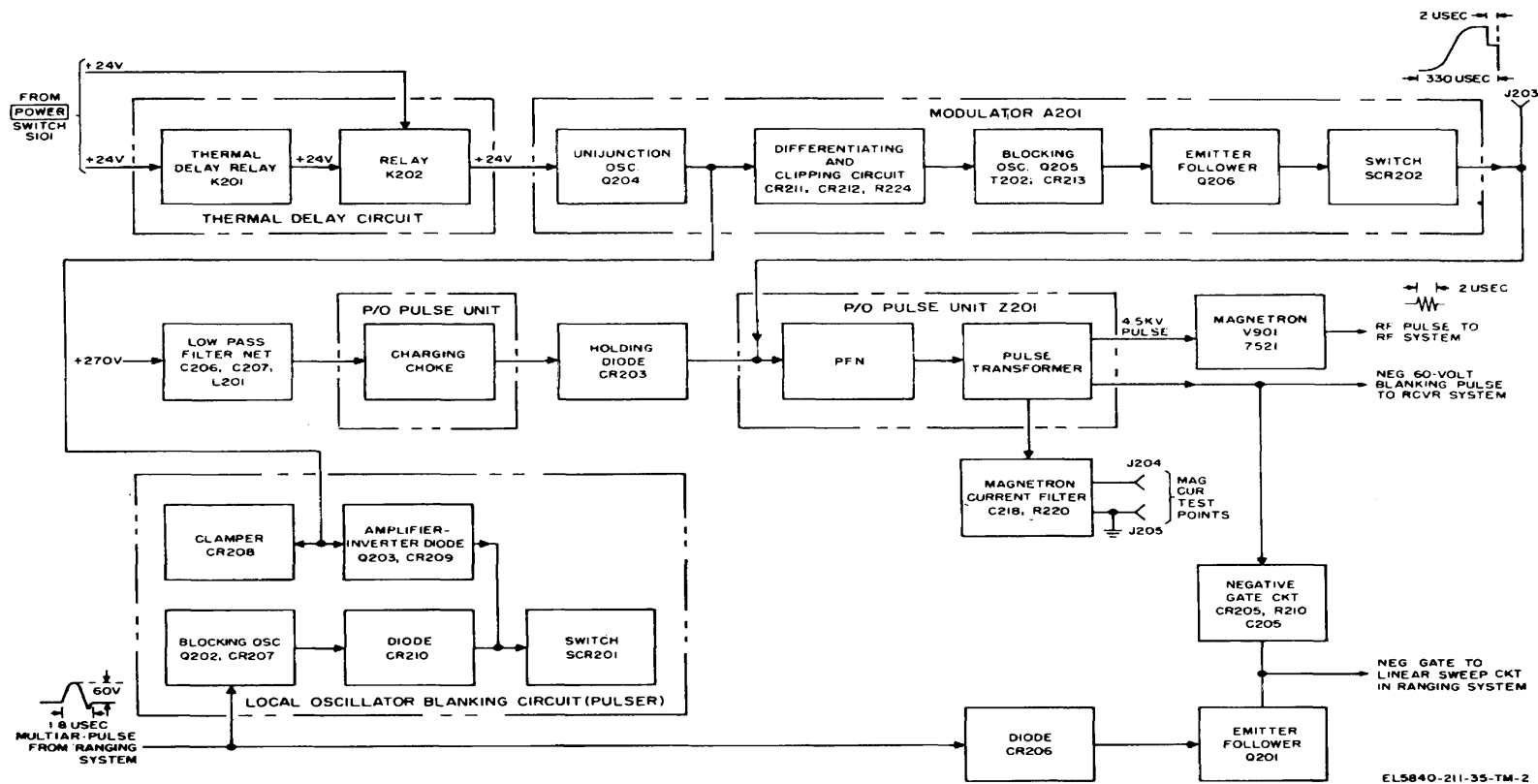

EL5840-211-35-TM-2

Figure 2-2. Transmitting system block anagram.

linear sweep circuit in the ranging system. In addition, this winding supplies the receiving system with a negative 60-volt blanking pulse.

f. Negative Gate Discharge Circuit. The negative gate discharge circuit consists of transistor Q201, diode CR.206, and resistors R1211 and R212. The negative overshoot of the multiar pulse from the ranging system turns transistor Q201 on, and drives it to saturation. Transistor Q201 then appears as a low impedance allowing capacitor C205 (in the negative gate circuit) to discharge through transistor Q201 toward ground.

g. Magnetron V901. Magnetron V901 receives a pulse of approximately 4.5kv, having a duration of 0.2 microsecond, from the pulse transformer of pulse unit Z201 and delivers RF energy in the form of a nominal 0.5-kw pulse to the RF system.

2-16. Thermal Delay Circuit

a. Thermal delay relay K201 has a time delay of approximately 90 seconds which postpones the application of +24 volts to the modulator to allow the tube filaments of the radar set to preheat. Thermal delay relay K201 is operated by + 24 volts, and the relay contacts close approximately 90 seconds after POWER switch S101 is set to STANDBY, TRAN-SMIIT, or RANGE.

b. If the POWER switch is set to STANDBY, TRANSMIIT, or RANGE, +24 volts will be applied through pin 26 of plug P101 and jack J101, and pin F of jack J201 and plug P201, to the heating element (pins 2 and 3) of thermal delay relay K201. After approximately 90 seconds, the bimetallic element of the thermal delay relay closes contacts 5-7, and the current flows through the coil (pins 1 and 5) of relay K202. When relay K202 is operated, contacts 8-6 and 24 will close, and contacts 3-4 and 7-8 will open. When contacts 3-4 open, the thermal delay heating element circuit is opened. When contacts 2-4 close the circuit through pins 1 and 5, and contacts 24 form a low-resistance path to ground, thus forming a holding circuit for relay K202. When contacts 8-6 close, +24 volts is applied to the modulator from either the TRANSMIT or RANGE position of the POWER switch, pin 19 of plug P101 and jack J101, and pin A of jack J201 and plug P201. In this manner, there is a delay of approximately 90 seconds before +24 volts applied to the modulator. The purpose of this delay is to prevent magnetron V901 from being pulsed prior to an adequate warmup period

for the magnetron filament. The lack of a proper warmup period may result in damage to the magnetron.

2-17. Modulator A201

a. When +24 volts is applied to the prf generator from the thermal delay circuit, the prf generator will provide a 0.4-microsecond, 4-volt trigger pulse to silicon controlled rectifier SCR202. This is accomplished by using the trailing edge of pretrigger pulse generated by unijunction oscillator Q204 to trigger a blocking oscillator circuit, using transistor Q205 and pulse transformer T202. An emitter follower stage, consisting of transistor Q206 and transformer T203, accepts the blocking oscillator output and develops a driving signal of 4 volts to the SCR202 which functions as a trigger switch.

b. Unijunction transistor Q204 is a three-terminal silicon element whose unique operating characteristics allow generation of a bistable oscillation, using only one active element. The important characteristics of this solid state device are a negative resistance characteristic uniform with temperature, a high pulse current capability, a stable firing voltage, and a very low value of firing current. The unijunction transistor is basically made up of the two ohmic contacts placed on the opposite ends of an n-type silicon bar (A, fig. 2-4). A normal resistance of between 5,000 and 10,000 ohms exists between these two contacts. A p-type junction contact (emitter) is located on the opposite side of the bar from the ohmic contact. If one of the ohmic contacts (B,) is grounded and the other (B2) has an applied positive voltage, a net positive voltage will exist at the silicon bar if no voltage is applied to the emitter. This can be illustrated as being represented by a voltage divider circuit (B; fig. 2-4). When a low positive potential (below the level of voltage developed at the silicon bar) is impressed on the emitter a reverse bias will exist between emitter and both contacts. A threshold voltage will be reached, however, if the voltage impressed on the emitter will be exceeded by the voltage level developed at the silicon bar by the ohmic contacts. After this point is reached, the emitter to ohmic contact (B,) is forward-biased. Holes are injected in the silicon bar from the emitter, and a decrease in resistance is achieved between the emitter and contact B,. From this

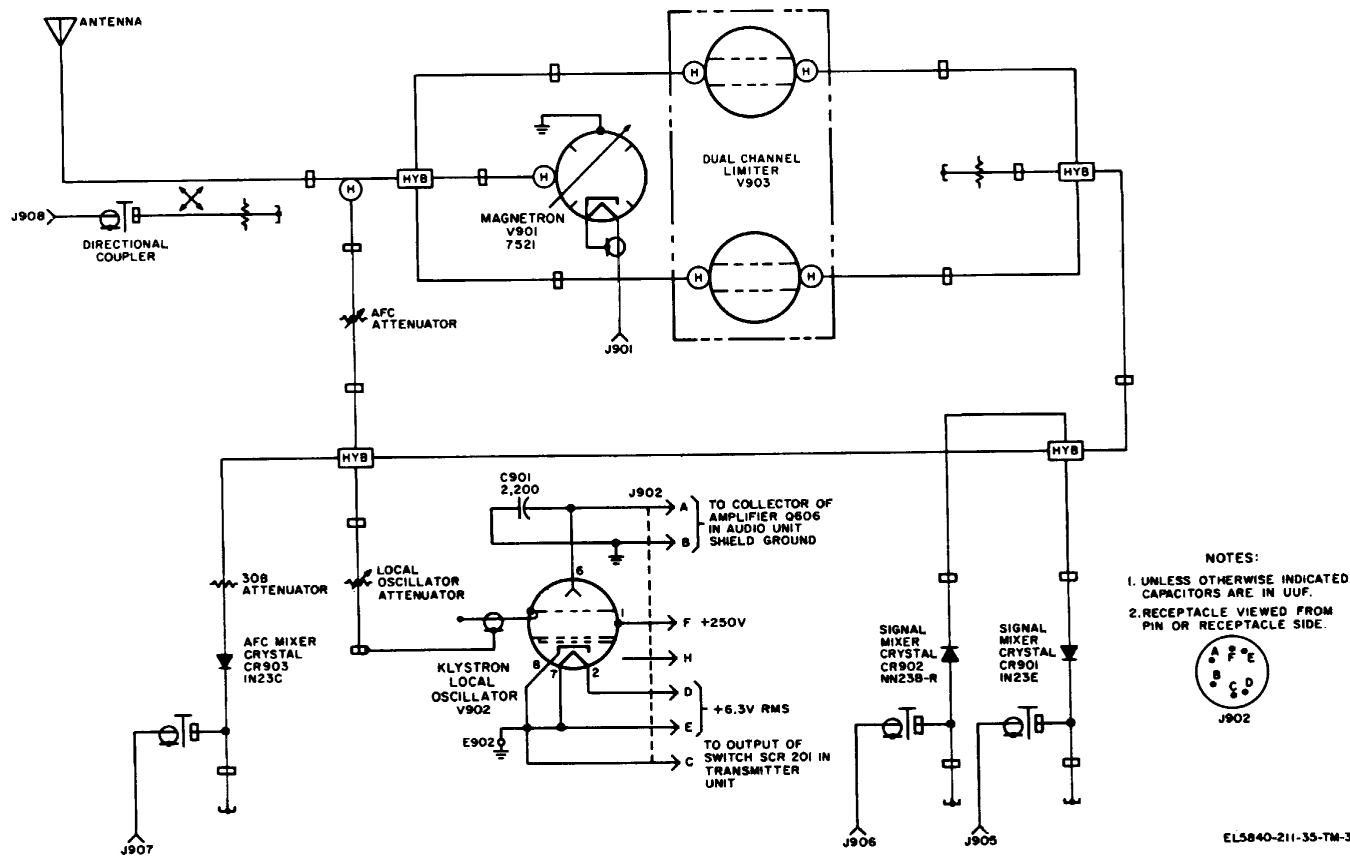

Figure-2-3. Microwave Assembly, complete schematic diagram.

point to saturation, the emitter voltage will decrease with increase in emitter current. The unijunction transistor has three operation states: a reverse-biased (open state) or high positive resistance state, a negative resistance state, and a low positive resistance state. The voltage current emitter characteristics of the unijunction transistor are shown in C, figure 2-4. The transition points are the peak and valley point. To the left of the peak point is the cutoff region of high positive resistance between the emitter and contact B₁. Between the peak and valley point is the negative resistance region where the emitter voltage decreases with increased emitter current. The valley point represents the saturation point of hole migration between emitter and contact B₁. After the valley point, the emitter voltage once again increases with increased emitter current. The dynamic resistance between emitter and contact B₁ is once again positive, but of low value.

c. If relay K202 is operated and the power switch is set to TRANSMIT or RANGE, +24 volts from the power converter will be applied to the emitter of Q204 (fig. 7-6). Resistor R213 and capacitor C217 serve to decouple the pulse signal from the pretrigger generator from other circuits in the radar set. Capacitor C219 charges toward +24 volts through resistors R213, R202, and R221. The voltage across C219 is impressed on the emitter of unijunction transistor Q204.

Until the voltage level of 14 volts is reached, unijunction transistor Q204 is back-biased (or in the open state) so that the emitter to base B₁ is a relative high resistance value. If a voltage level of 14 volts is exceeded, the unijunction transistor will be forward-biased. The unijunction transistor will go from a negative resistance state to a closed state. The resistance of emitter to base 1 (grounded) becomes very low. Capacitor C219 discharges through unijunction transistor Q204.

When capacitor C219 is sufficiently discharged, the current from the emitter to base 1 of the unijunction transistor will fall below the current that will sustain forward bias, and the unijunction transistor will revert to its open state. The charging time constant of C219 may be varied by changing R202. Varying the charging time constant varies the repetition rate from 100 to 600 microseconds. During the interval of unijunction transistor Q204 forward conduction, the ohmic contact value between base 1 and base 2 is altered. Current will flow from +24 volts through JR223 and base 2 to base 1, to ground, and develop a negative pulse of 5 microseconds duration. This pulse serves as a trigger pulse whose leading edge is used to pulse the klystron local

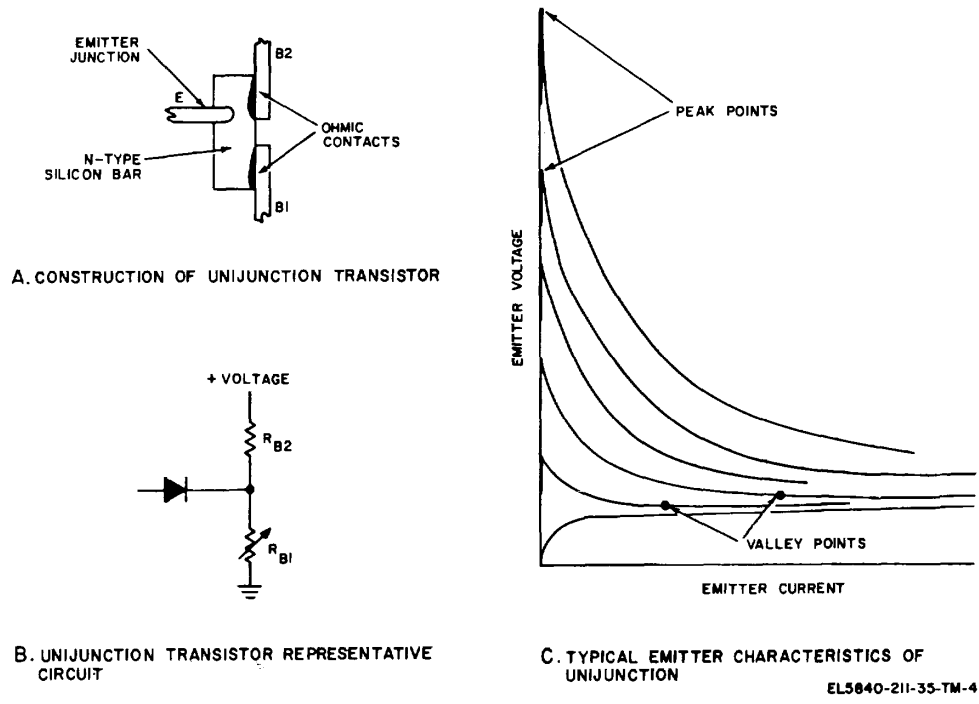

Figure 2-4. Unijunction transistor characteristics.

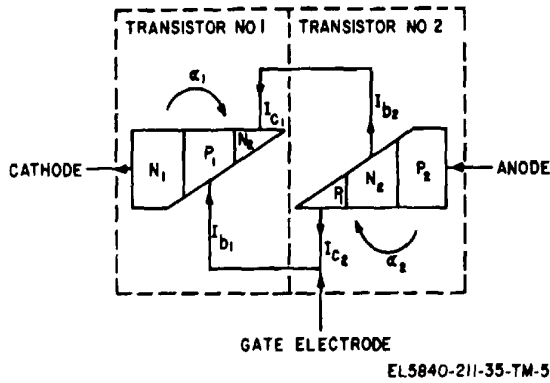

Figure 2-5. Simplified version of silicon controlled rectifier.

oscillator blanking gate. The trailing edge serves as the zero pulse timing trigger. The pretrigger pulse is ac coupled through the network of C221, CR211, CR212, and R224 to blocking oscillator Q205. Capacitor C221 serves as a dc blocking capacitor, and CR211, CR212, and R224 form a differentiator and clipping circuit. After the 5microsecond trigger pulse is differentiated, the leading and trailing edge of the pretrigger pulse is retained at the junction of C221 and CR211. Diode CR212 is a diode in series with the differentiated pulse, and presents a high resistance to the negative-going part of the differentiated pulse so that only a small portion of the negative pulse is developed at the junction of voltage divider CR212 and R224. Diode CR212 presents a low resistance to the positive-going portion of the differentiated pulse so that almost all of this pulse is present at the junction of voltage divider CR212 and R224. The amplitude of this positive-going signal (the trailing' edge of the trigger) is 5 volts and is used to trigger the blocking oscillator formed by Q205 and T202. The primary of transformer T202 is connected to the collector of transistor Q205. The secondary is connected to the emitter of transistor Q205. When no signal is impressed on the base, only a small residual current flows through Q205, making the emitter positive with respect to the base. Therefore, transistor Q205 normally is near cutoff. When a positive pulse is impressed on the base of transistor Q205, the emitter to base current increases; this, in turn, increases the collector current. A negative-going pulse is developed on the primary of T202. This negative-going pulse is mutually coupled to the secondary of T202. The pulse transformer with a turns ratio of 5.3 : 1 : 2 delivers much of this negative-going pulse to the emitter of transistor Q205, further increasing the emitter current and collector current in turn. This regenerative process is cumula-

tive until saturation is achieved; at which time, the process is reversed. The collector current begins to increase, developing a positive-going voltage on the primary of T202. The positive-going voltage mutually coupled to the secondary of T202 and, therefore, to the emitter of transistor Q205, acts to cut off transistor Q205. Therefore, a positive pulse, having the fast rising slope and fast falling slope of a typically high-gain regenerative circuit, is developed across the tertiary winding of T202 (mutually coupled from the other windings of T202). The amplitude and width of this pulse is 4 volts and the duration is 0.4 microsecond.

d. In the blocking oscillator circuit, CR213 serves to dampen the positive "overshoot" in the primary of T202. Resistor R225 is a current limiting resistor. The positive pulse developed in the tertiary winding of T202 is coupled to emitter follower transistor Q206. This transistor functions to present a low impedance to pulse-forming circuit switching silicon controlled rectifier SCR202. Transformer T203 is used as the coupling element between emitter-follower transistor Q206 and silicon controlled rectifier SCR202. Resistor R226 serves as a current limiting resistor. Resistor R228 is used to eliminate misfiring of the SCR by presenting a low impedance discharge path at the gate.

2-18. Pulse Unit Z201

a. The pulse-forming circuit receives an input of +270 volts from the power converter system and a 4-volt trigger pulse from the modulator to trigger switch SCR202. The pulse-forming circuit provides the following outputs:

- (1) A negative 4.5-kilovolt pulse to the magnetron.
- (2) A negative gate to the ranging system.
- (3) A negative 60-volt blanking pulse to the receiving system.
- (4) A sampling of the magnetron current to the magnetron current filter.

b. Positive 270 volts applied through variable resistor R207 when POWER switch S101 is set at TRANSMIT or RANGE. Variable resistor R207 controls the current in pulse unit Z201 and, subsequently, the magnetron pulse current. Filter (06, C207, and L201, filters any ripple from the +270-volt supply.

c. During the charging period of the pulseforming circuit, silicon controlled rectifier SCR202 does not conduct and presents an infinitely high resistance.

d. When +270 volts is applied across the uncharged circuit, electrons will flow from ground through the pulse transformer primary winding to charge the pulse-forming line. The flow of electrons from pin 10 to pin 5 of the charging choke builds up a magnetic field in the winding of the charging choke. When the pulse-forming line is charged to +270 volts, the magnetic field around the charging choke will collapse, releasing its stored energy, continuing current flow to the pulse-forming line and capacitor C216, causing them to charge to approximately 540 volts. Holding diode CR203 is reverse-biased when the pulse-forming line is fully charged, and prevents the pulse-forming line from discharging into the power source. Therefore, the pulse-forming line will remain fully charged until silicon controlled rectifier SCR202 conducts.

e. While the pulse-forming line is charging, silicon controlled rectifier SCR202 is not conducting. When the 4-volt positive trigger pulse from the modulator is applied to the gate electrode of SCR202, the rectifier conducts and acts as a closed switch. The silicon controlled rectifier is a solid state four layer semiconductor (PNPN) device equivalent to a thyatron. In its normal state, prior to being triggered, there is no current flow from anode to cathode. As illustrated in figure 2-5, an imaginary cutting of the four-layer semiconductor device into a complementary pair of transistors shows that, as the gate electrode current increases, the base current of transistor No. 1, the collector current of transistor No. 1, increases. Since the collector of transistor No. 1 is also the base of transistor No. 2, it increases collector current of transistor No. 2. It is obvious that, since the collector of transistor No. 2 is the base of transistor No. 1, a regenerative cycle is achieved. Once the cycle is started by injection of gate electrode current beyond a threshold level, the positive feedback nature of the PNPN semiconductor device will continue until, in effect, transistors No. 1 and No. 2 will be driven into saturation. All three junctions are forward-biased, so that, in effect, the four-layer device acts as a two-layer device. Current will flow from anode to cathode. Similarity to the thyatron is that a trigger pulse must be utilized to turn on the silicon controlled rectifier and, once conduction starts, the gate electrode has no further control. Conduction will continue in the silicon controlled rectifier until the current from anode to cathode drops below a low value called the holding current. Then SCR202 is brought into conduction by the positive trigger developed in the modulator,

it permits the pulse-forming line to discharge through the pulse transformer primary winding. The voltage on these capacitors divides between the impedance of the pulse-forming line and the impedance of the pulse transformer primary winding. A pulse of approximately 270 volts, having a width of 0.2 microsecond, is developed across the primary winding by this discharge current. The width of this pulse depends upon the total capacitance and total inductance of the pulse-forming line.

f. Because the impedance of the pulse-forming line is slightly larger than the impedance looking into the primary of the pulse transformer, a negative reflected pulse is developed after the 0.2microsecond pulse. This negative reflective pulse reduces the anode current of SCR202 to a value below its holding current; this action switches off the rectifier.

g. Pins 8 and 9 of pulse unit Z201 receive 7 volts rms from the power converter system to heat the magnetron filament. The plate return of the magnetron is through magnetron current filter C203 and R205 to pin 8 of pulse unit Z201. Jack J203 serves as a test point for checking the waveform at the anode of silicon controlled rectifier SCR202. Resistor R227 is inserted in series with J203 to eliminate the possibility of misfire of the SCR202.

h. Filters, consisting of C212, C213, L204, C214, C215, AND L205, filter any ripple from the magnetron filament voltage.

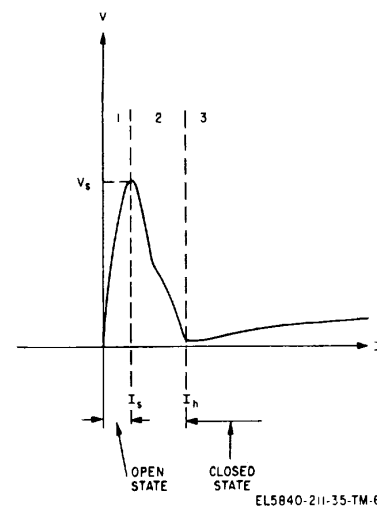

Figure 2-6. Four layer diode, voltage current characteristics.

2-19. Negative Gate Circuit

a. The negative gate circuit receives a negative pulse from pulse unit Z201 and generates the negative gate which is applied to the linear sweep circuit in the ranging system.

b. The pulse transformer of pulse unit Z201 has a range trigger winding (winding 4-111) that develops a negative 60-volt pulse which charges capacitor C205 through diode CR205 and current limiting resistor R210. The charge on capacitor C205 appears as a negative gate to the linear sweep circuit in the ranging system. This gate is applied to the ranging system through pin D of plug P201.

c. Winding 4-11' also supplies a negative 60volt blanking pulse to the signal IF amplifiers in the receiving system. This pulse is necessary to prevent the high-power transmitter pulse -from driving the receiving system into saturation. The blanking pulse is supplied from pin 4 of pulse unit Z201 to output jack J206.

2-20. Negative Gate Discharge Circuit

a. To prevent range instability, a negative gate discharge circuit is used to discharge capacitor C205 in the negative gate circuit. This discharge circuit consists of emitter follower Q201, resistor R211, R2-12, and diode CR206.

b. Emitter follower Q201, is biased at cut off by resistor R212 and, therefore, appears as a high impedance to capacitor CM05. The negative overshoot of the multiar pulse from the ranging system forward .biases diode OR206 allowing current flow through diode CR206 and emitter follower Q201. This current flow drives emitter follower Q201 into saturation and allows capacitor C206 to discharge through emitter follower Q201 toward ground.

2-21. Magnetron V901

a. Magnetron V901 is a variable, resonant cavity, magnetron oscillator which generates short pulses of high-power RF energy at frequencies between 8,900 and 9,400 MHz.

b. Magnetron V901 consists of an indirectly heated diode (resonant cavity) mounted between the poles of a permanent magnet. The position of the diode is such that the electric field existing between the cathode and plate is perpendicular to the magnetic field of the permanent magnet. When the magnetic field is of the proper strength, the cathode is made sufficiently negative with respect to the grounded plate, and os-

cillations will take place within resonating cavities of the magnetron. The frequency of the oscillations produced is determined by the size of these resonating cavities. Magnetron V901 can be mechanically tuned from 8,900 to 9,400 MHz by variation of the size of the resonating cavities. This is accomplished by rotating the MAG. TUNER control which is attached to the tuning shaft of the magnetron.

c. The 7 volts rms from the power converter system is applied to the magnetron filament through the bifilar-wound pulse transformer. The cathode of the magnetron is attached to one side of the filament input. A pair of filament input leads carries the 7-volt rms filament voltage and the 4.5-kv pulse from pins 1 and 3 of pulse unit Z201 through plug P901 to jack J901 of the magnetron. Due to a 2-volt drop in the secondary windings of the pulse transformer, only 5 volts are applied to the magnetron filament. Since the bifilar-wound secondary windings of the pulse transformer are in series opposition to one another, and since the voltages developed across them are equal and in phase, they effectively cancel one another and only 5 volts, the filament voltage, appears across the magnetron filament.

d. The negative 4.5-kv pulse is applied to the cathode of the magnetron and causes oscillations to occur in the resonating cavities of the magnetron. These oscillations will be between 8,900 and 9,400 MHz, depending upon the adjustment of the MAG. TUNER control.

e. The magnetron has a pickup loop which is inductively coupled to the oscillating magnetic field produced by the resonating cavities. Part of the pickup loop lead in the resonation cavity extends into a section of the waveguide that is part of the magnetron structure. The lead acts as a probe which introduces 0.2-microsecond pulses of 0.5-kw RF energy into the section of waveguide on the magnetron. This waveguide section also contains an iris which acts as a mechanical transformer which resembles an iris. The purpose of the transformer is to match the impedance of the magnetron to that of the waveguide. A choke joint (para 2-25c) connects the section of waveguide on the magnetron to hybrid waveguide assembly No. 1 of the RF system.

2-22. Magnetron Current Filter

a. The magnetron current filter, which consists of resistor R220 and capacitor C218, provides the means for measuring the magnetron current.

b. Resistor R220 is connected between the secondary of the pulse transformer (pin 8 of pulse unit Z201) and ground. Capacitor C218 is connected in parallel with resistor R220. Electron flow through the filter circuit is from the pulse transformer secondary through the magnetron to ground, and from ground through resistor R220 back to the pulse transformer secondary.

The voltage developed across resistor R220 and filtered by capacitor C218 is measured between test jacks J204 and J205 on the transmitter unit by means of an external voltmeter. The average magnetron current is equal to the voltage across resistor R220 divided by the 1,000-ohm resistance of resistor R220.

Section IV. RF SYSTEM FUNCTION

2-23. General

a. The RF system channels RF pulses from the magnetron in the transmitting system to the antenna which radiates them outward into space. The RF system also channels the target echo pulses from the antenna to the signal mixers in the receiving system.

b. The relationship of the RF system with respect to other functional systems of the radar set is covered in paragraph 2413.

2-24. System Block Diagram Discussion

(fig. 2-7)

a. General. The RF system consists of the balanced duplexer, those portions of hybrid waveguide assemblies No. 1 and No. 2 which are not part of the balanced duplexer, the antenna, the afc coupler, and the directional coupler. Magnetron V901 which is attached to hybrid waveguide assembly No. 1 is part of the transmitting system. Klystron V902, signal mixer crystals CR901 and CR902, and afc fixer crystal CR903 are mounted on hybrid waveguide assembly No. 2. The klystron and the signal mixer crystals are part of the receiving system; the afc mixer crystal is part of the afc system.

b. Balanced Duplexer. The balanced duplexer consists of two short slot hybrid couplers which are integral parts of hybrid waveguide assemblies No. 1 and No. 2, and of the dual channel limiter. The balanced duplexer is a microwave device which connects the antenna to the transmitting system during transmission and to the receiving system during reception. This action is accomplished by using the dual channel limiter in conjunction with the two short slot hybrid couplers as a switch which is operated by the energy from the transmitting system, and which protects the sensitive components of the receiving system from the damaging effect of the high energy from the transmitting system.

c. Afc Coupler. The afc coupler provides a sample of the magnetron output energy (50 to 2-16

60-db attenuated magnetron pulses) for use in the afc system. This unit consists of the flexible waveguide assembly and the afc attenuator located on the narrow wall of hybrid waveguide assembly No. 2.

d. Directional Coupler. The directional coupler (fig. 2-7) provides a sample of the magnetron output energy (15 to 17-db attenuated magnetron pulses) to permit measurements of magnetron power and frequency by means of external test equipment. Test echo pulses from external test equipment may also be supplied through the directional coupler. This unit consists of a short section of closed rectangular waveguide mounted on the board wall of hybrid waveguide assembly No. 1, and the directional coupler cable assembly.

e. Antenna. The antenna (fig. 27) consists of two dipoles mounted on the antenna feed assembly and a parabolic reflector. Rf energy from the magnetron radiates from the dipoles on the antenna feed assembly and is focused into a conical beam of a 6.2-degree solid angle at the half-power points by the parabolic reflector. Returned target echoes are collected by the reflector, focused to the dipoles of the antenna feed assembly, and channeled back to the receiving system.

2-25. Waveguide Theory

The term waveguide refers to a single hollow conductor that is used to guide electromagnetic waves from one place to another.

a. Mode of Operation. The description of waveguide operation makes use of the electromagnetic waves within the guide. It is possible to propagate several different types of electromagnetic waves within a waveguide. Each of these wave types is characterized by a different electric and magnetic field configuration. Associated with each type wave is a cutoff frequency; that is, the waveguide will not propagate that type wave when the frequency of the wave is less than a critical cutoff value, determined by the dimensions of the waveguide. The dimensions of the waveguide used in Radar Set AN/PPS-4A were

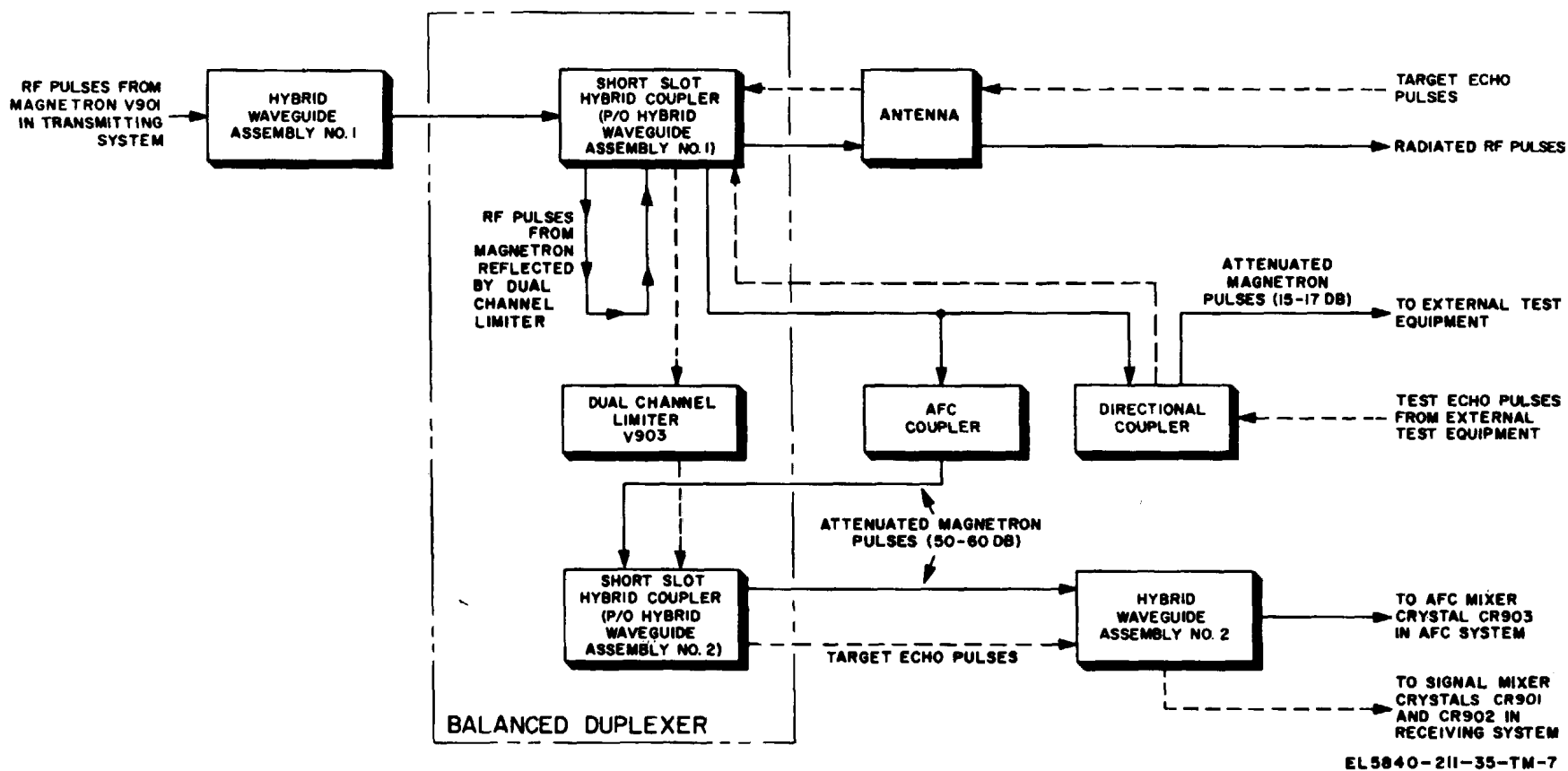

Figure 2-7. RF system block diagram.

chosen to propagate the wave type having the lowest cutoff frequency in comparison with other wave types that can be propagated. Whenever the waveguide propagates the wave type having the lowest cutoff frequency, the waveguide is said to be operating in the dominant mode.

b. Field Configuration. The electric and magnetic field configuration in the waveguide Radar Set AN/PPS-4A is illustrated in figure 2-8.

(1) The electric field is perpendicular to the A walls, has maximum intensity at the center of the A walls, and decreases sinusoidally to zero at the B walls.

(2) The magnetic field is in the form of loops that lie in planes parallel to the A walls (perpendicular to the electric field).

c. Choke Joints (fig. 2-9). Choke joints are used as a convenient mechanical means of connecting two sections of a waveguide together with a minimum loss of energy. The choke joint consists of a plain flange and a choke flange (see figure 2-9). The choke flange has a circular slot a quarter of a wavelength deep and at an average distance of a quarter of a wavelength from the inner surface of the guide. The L-shaped cavity formed when the choke flange is attached to the plain flange (B, fig. 2-9) is similar to a one-half wavelength transmission line shorted at the far end (X). When energy attempts to leak out of the waveguide at the point, standing waves of voltage and current are set up on the L-shape

cavity, and the short at the far end is reflected to the input end (Y) which is one-half wavelength away. Thus, the choke joint effectively short circuits the two sections of waveguide at Y in spite of the fact that there is no metallic connection at Y. In Radar Set AN/PPS-4A, choke joints are used to connect the magnetron to the RF system and to connect the antenna feed assembly to the hybrid waveguide assembly No. 1.

d. Flange Gaskets. Flange gaskets are used wherever two sections of plain flange waveguide are connected. The flange gaskets ensure a good surface-to-surface contact over the entire flange area, and thereby prevent or minimize energy leakage from the waveguide at the joint.

2-26. Balanced Duplexer

a. General. The balanced duplexer (fig. 2-7) is the microwave equivalent of a fast electromagnetic switch. During transmission, the function of the balanced duplexer is to connect the antenna to the transmitting system while at the same time isolating the receiving system from the transmitting system so as to prevent damage to signal mixer crystals CR901 and CR902 by the high energy pulses. During reception, the function of

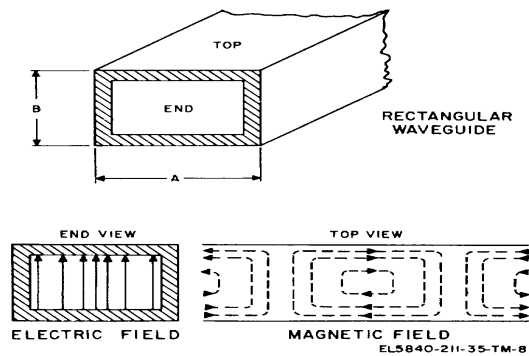

Figure 2-8. Waveguide characteristics.

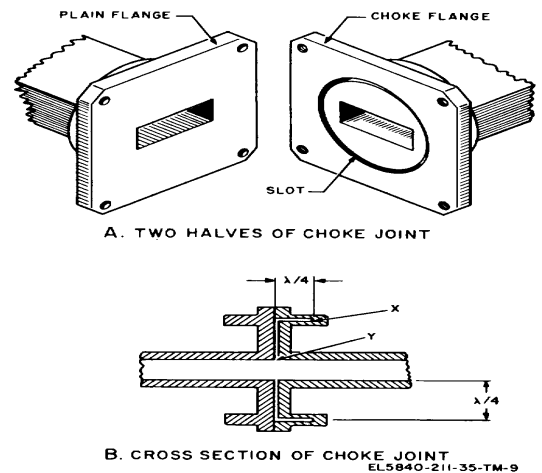

Figure 2-9. Choke joints.

the balanced duplexer is to connect the antenna to the receiving system and to prevent the target echo pulses from entering the transmitting system. This action is obtained by using the combination of the dual channel limiter and the short slot hybrid couplers which are parts of hybrid waveguide assemblies No. 1 and No. 2. The operation of these components and the description of the signal paths during transmission and reception are described below.

b. Dual Channel Limiter (fig. 2-10). The dual channel limiter is a semiconductor device. A schematic representation of one limiter section is shown in figure 2-10. Each limiter section contains two varactor limiter diodes which provide a low loss path between the input and output at low power levels of less than 1 milliwatt. When high energy rf pulses from magnetron V901 enter the input of each of the semiconductor limiter sections, the limiter diodes interact and are forward conducting. This provides a short circuit in the waveguide section. The two limiter diodes are positioned 1/4-wavelength apart so that the isolation provided by each of the diodes is additive, thereby providing very high attenuations to the high incident RF energy. The energy of the target echo pulses is not sufficient to cause the limiter diodes to interact and become forward conducting, therefore, the target echo pulses pass through the limiter. In this case, the characteristic impedance of dual channel limiter is equal to the characteristic impedance of the adjacent waveguide and hence, the limiter impedance is "matched" to the impedance of the waveguide.

c. Short Slot Hybrid Coupler (fig. 2-11). The short slot hybrid coupler is basically a broadband directional coupler with a coupling ratio of 3 db and an isolation in excess of 25 db. The 90-degree phase-shift characteristic of the hybrid is shown in figure 2-11. At the coupling aperture located

in the center wall of the short slot hybrid there is a 90-degree phase difference between the signal which passes through the aperture and the signal which continues in a straight line path past the aperture along the waveguide. Since the short slot hybrid coupler has an isolation of 25 db or greater, there is no backward wave shown on figure 2-1,1 when the signal passes through the aperture. d. Signal Path During Transmission (fig. 211). The path of the RF pulses from the magnetron is shown in A of figure 2-11. When the high power RF pulses reach the dual channel limiter, the diodes conduct and an effective short circuit appears across the input of the dual channel limiter. The relative phase angles of 0, 90, and 180 degrees of the signal vectors which represent the magnitude and direction of the energy flow in the waveguide are indicated in figure 2-11 as $\angle 0$, $\angle 90$, and $\angle 180$, respectively. For convenience, the phase angle of the RF pulses from the magnetron is chosen to be $\angle L$; this may be done arbitrarily since only the relative angles are significant. At the two coupling apertures located in the center wall of the short slot hybrid couplers, there is a 3-db split in energy and a phase difference of 90 degrees between the signals as described previously. The signal incident on the input of the dual channel limiter undergoes a phase shift of 180 degrees when it is reflected from the actuated limiter. As shown in A, figure 2-11, the signal vectors back to the magnetron are 180 degrees out of phase and, being equal in magnitude, they cancel. The signal vectors to the antenna are in phase and they add. However, the effective short circuit across the input of the dual channel limiter does not prevent some of the incident magnetron energy from leaking through the dual channel limiter. It is shown in A, figure 2-111 that the leakage signal vectors to the balanced signal mixer are 180 degrees out of phase and, being equal in magnitude, they cancel. This provides additional protection for the signal mixer crystals. The leakage signal vectors which are in phase and add are absorbed by the dissipate termination.

e. Signal Path During Reception (fig. 2-11). The path of the received target echo pulses from the antenna is shown in B, figure 2-11. Since the power of the target echo pulses is not sufficient to activate the dual channel limiter, a matched impedance appears across the input of the dual channel limiter. As a result, the target echo pulses pass through the dual channel limiter. As is shown in B, figure 2-11, the signal vectors to

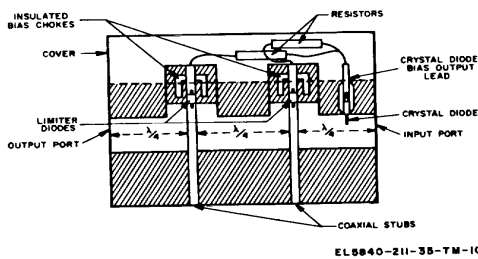

Figure 2-10. Section of dual channel limiter.

the balanced signal mixer are in phase and add; the signal vectors to the termination are 180 degrees out of phase and, being equal in magnitude, they cancel.

2-27. Afc Coupler

(fig. 2-12)

Coupling between the afc coupler flange and hybrid waveguide assembly No. 1 is accomplished by means of a circular iris (window) in the center of the narrow wall of hybrid waveguide assembly No. 1. The sample of magnetron energy is channeled through the flexible waveguide assembly and hybrid waveguide assembly No. 2 to the afc mixer crystal CR903 where it is combined with the pulsed signal from the klystron local oscillator to form IF pulses for use in the afc system. Depending on the adjustment of the afc attenuator, the afc coupler provides an attenuation of from 50 to 160 db between the power level in hybrid waveguide assembly No. 11 and the afc mixer crystal.

2-28. Directional Coupler

(fig. 2-12)

Coupling between the directional coupler and hybrid waveguide assembly No. 1 is accomplished by means of two slotted irises (windows) symmetrically spaced on a diagonal of hybrid waveguide assembly No. 1. The directional coupler contains a pickup probe which terminates in the directional coupler cable assembly. Applicable test equipment may be connected to the coaxial connector at the end of the cable assembly for aligning and testing procedures; for example, checking the power level and frequency of the RF pulses from the magnetron. The directional coupler provides an attenuation of from 15 to 17 db between the power level in hybrid waveguide assembly No. 1 and the coaxial connector output. The exact directional coupler attenuation is stamped on the directional coupler surface.

2-29. Energy Flow in RF System

(fig. 2-12)

An overall view of the energy flow in the RF system is shown in figure 2-12. As shown on the figure, transmitted pulses from magnetron V901 are channeled through hybrid waveguide assembly No. 1 into the antenna. A sample of the magnetron energy passes through the circular iris in the afc coupler flange, through the afc attenuator, and through a 3-db attenuator pad before

reaching afc mixer crystal CR903. Another sample of the magnetron energy passes through the slotted irises into the directional coupler. The target echo pulses are channeled from the antenna through hybrid waveguide assemblies No. 1 and 2 before reaching the balanced signal mixer comprised of signal mixer crystals CR901 and CR902. The continuous signal from klystron local oscillator V902 is fed into hybrid waveguide assembly No. 2 and is channeled to signal mixer crystals CR901 and CR902 and afc mixer crystal CR903.

2-30. Antenna

a. General. The antenna consists of a double dipole antenna feed assembly and a parabolic reflector. The antenna has a gain of approximately 27 db with a side lobe attenuation of approximately 19 db.

b. Parabolic Reflector. The reflector is parabolic in shape with an overall diameter of 14.6 inches. This overall diameter includes the necessary mounting structures. The effective reflection surface of the reflector is 13.5 inches in diameter, and the focal length of the parabola is 4.5 inches.

c. Antenna Feed Assembly (fig. 2-13). The antenna feed assembly is a waveguide that provides tapered impedance matching between the rectangular waveguide input and the dipoles so that maximum power can be transferred to the exciter dipole. The antenna feed assembly is twisted to provide vertical polarization of the radiated beam. The radiating elements are two fixed dipoles located approximately one-half wavelength ($A/2$) apart. The two dipoles are designated as the exciter dipole and the parasitic dipole. The parasitic dipole is made longer than the exciter dipole to obtain the desired radiation pattern. The exciter dipole is positioned at approximately the focal point of the parabolic reflector.

d. Mode of Operation. The exciter dipole is excited directly by the RF pulses from the magnetron which flow through the antenna feed assembly. The parasitic dipole is in turn excited by the radiated energy from the exciter dipole. The size and spacing of the two dipole elements are chosen so that the parasitic dipole acts as an inductive reactance at the magnetron frequency (8,900 to 9,400 MHz). As a result, the fields radiated toward the parabolic reflector by the two dipoles are in phase and therefore reinforce each other; the fields radiated from the dipoles away from the parabolic reflector are out of phase and

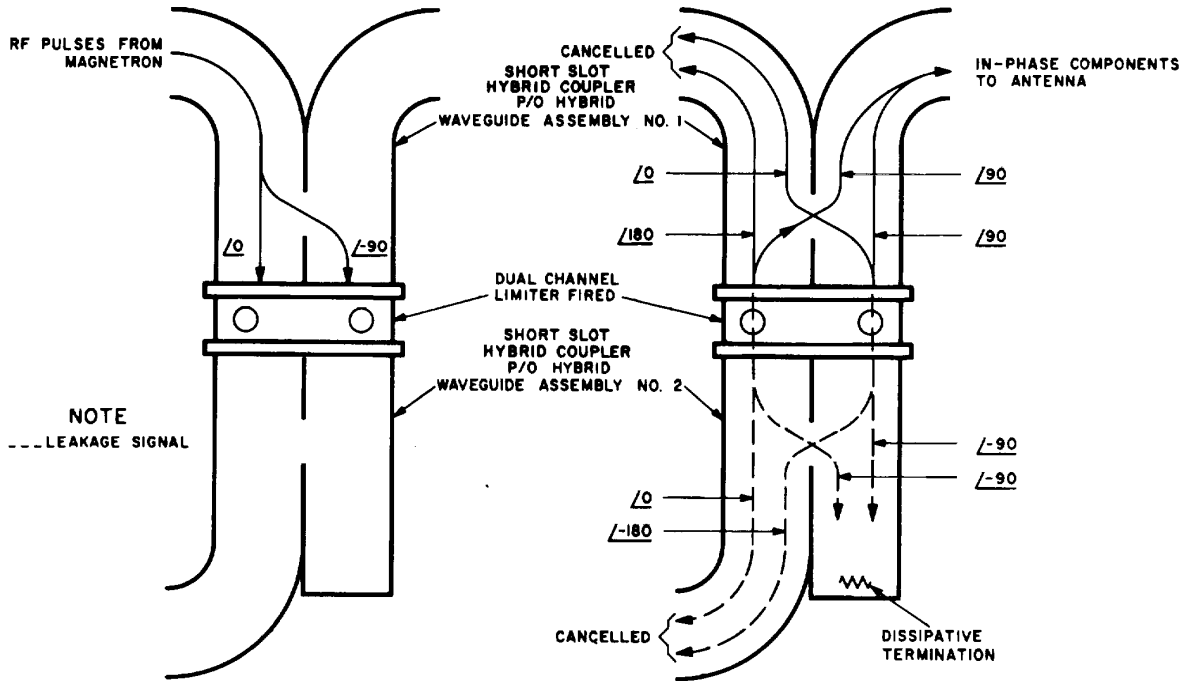

A. DUPLEXER TRANSMIT OPERATION

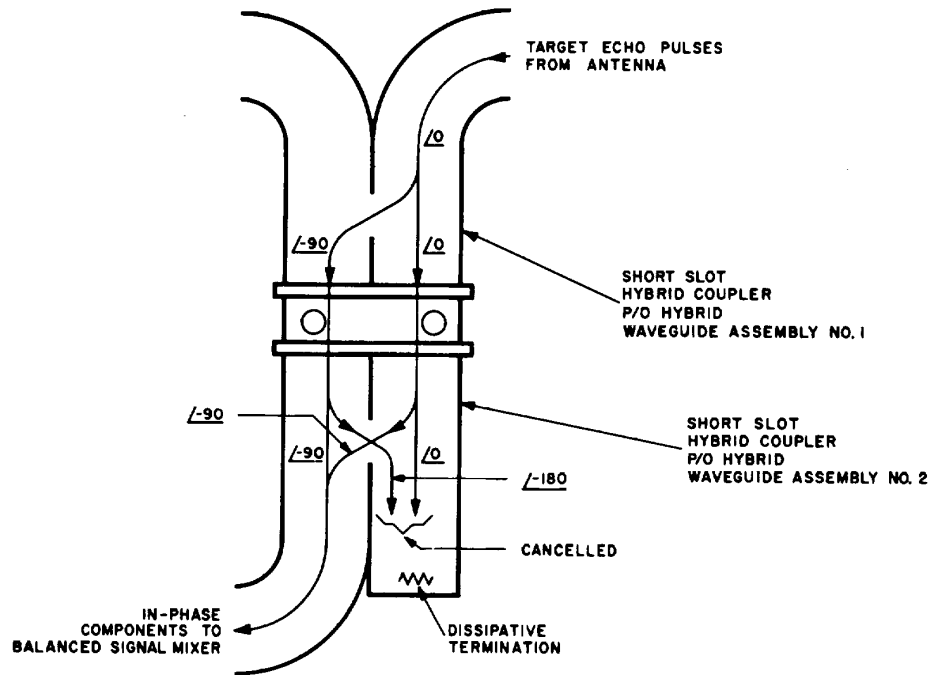

B. DUPLEXER RECEIVE OPERATION

EL5840-211-35-TM-11

Figure 2-11. Path of signal in balanced mixer.

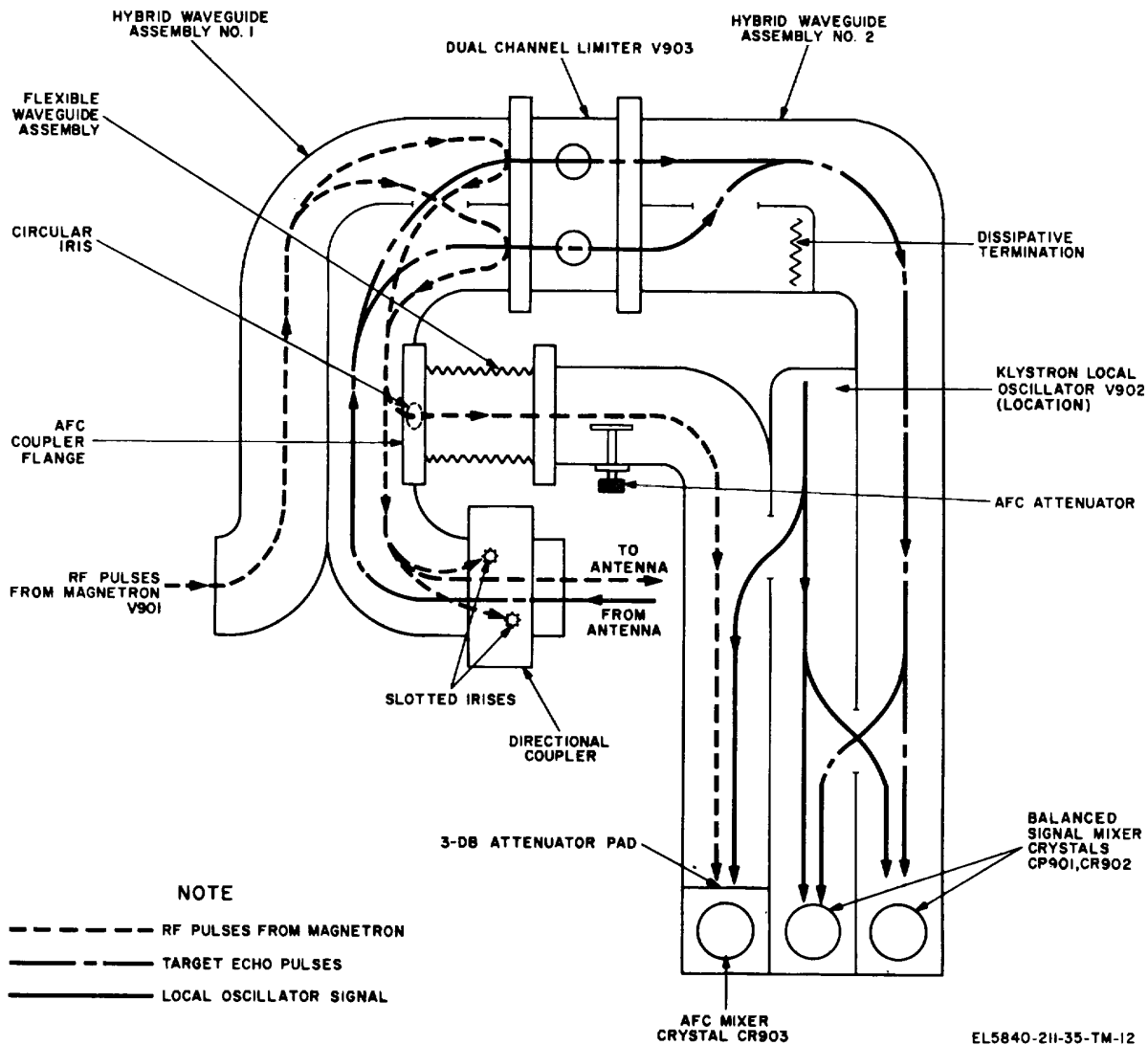

Figure 2-12. Energy flow in microwave assembly of RF system.

cancel each other. The parasitic dipole may be thought of as a reflecting element though, in fact, both the exciter dipole and the parasitic dipole radiate. The parabolic reflector reflects the incident energy from the dipoles in the form of a focused beam whose maximum intensity is coincident with the parabolic axis.

e. Radiation Pattern (fig. 2-14). The radiation pattern of the antenna is shown in figure 214.

Because of the directional characteristics of the parabolic reflector, most of the radiated energy is concentrated in the forward direction, as is evidenced by the large size of the main lobe compared to the side lobes. The broken lines adjacent to the axis of the main lobe represent points along which the radiated power density is one half as great as it is on the axis. The angle between these broken lines is defined as the beam width which equals 6.2 degrees.

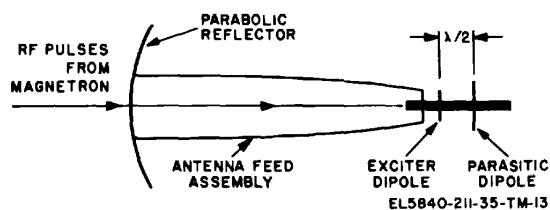

Figure 2-13. Antenna, functional schematic diagram

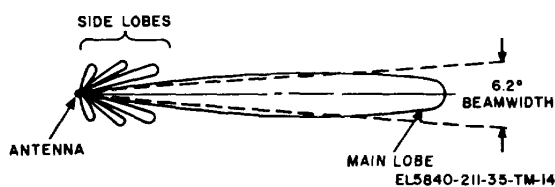

Figure 2-14. Antenna radiation pattern

Section V

2-31. General

a. The receiving system receives the target echo pulses from the antenna in the RF system and produces video signals which are fed to the boxcar detector in the ranging system.

b. The relationship of the receiving system with respect to other functional systems of the radar set is covered in paragraph 214.

2-32. System Block Diagram Discussion (fig. 2-15)

a. *General.* The receiving system consists of the frequency converter, the signal IF amplifier and detector, the video amplifier, and the blanking and limiting circuit.

b. *Frequency Converter.* The frequency converter mixes a pulsed signal provided by klystron local oscillator V902 with the received target echo pulses and produces a 30-MHz IF signal which is fed to the signal IF amplifier and detector. The mixing action is called heterodyning and takes place in the balanced signal mixer.

c. *Signal IF Amplifier and Detector.* The signal IF amplifier and detector consists of a double-tuned input network, signal IF preamplifier Q508, five signal IF amplifier stages Q501 through Q505, and video detector CR501 (fig. 2-15). If POWER switch S101 (fig. 7-13) is set to TRANSMIT, the 30-MHz IF signals from the frequency converter (fig. 2-165) will be amplified in signal IF preamplifier Q508 and in signal IF amplifiers Q501 through Q505, and detected in video detector CR501. The detected video signals from video detector CR501, are then fed to the video amplifier. If POWER switch S101 is set to RANGE, the dc power will be removed from signal IF preamplifier Q508 to prevent 30-MHz IF signals from entering signals IF amplifier Q501. The range marks from the afc system are then applied to the input of signal IF amplifier Q501 of the signal IF amplifier and detector. These range-marks are amplified and detected in the same

manner as the 30-MHz IF signals and provide a means of range calibrating the ranging system.

d. *Video Amplifier.* The video amplifier consists of amplifier Q506 and emitter follower output stage Q507. The video amplifier amplifies the detected video signals or range marks from the signal IF amplifier and detector, and sends them to the boxcar detector in the ranging system.

e. *Blanking and Limiting Circuit.* The blanking and limiting circuit is activated by the blanking pulse from the transmitting system and sends a pulse to the signal IF amplifiers. This pulse blanks the amplifiers during the transmitted pulse interval and thus prevents any leakage, due to the transmitted pulse, from saturating the amplifier and detector.

2-33. Frequency Converter

a. The frequency converter consists of local oscillator V902 and a balanced signal mixer.

b. Local oscillator V902 is a type 2K25/723B reflex klystron (fig. 2-16). The reflex klystron is a velocity-modulated microwave oscillator, the operation of which depends upon the modulation or change of speed of electrons passing through it. Electrically, it consists of a filament, a cathode, an accelerator grid, two resonator grids, an internal cavity resonator, and a reflector. The filament (fig. 2-17) indirectly heats the cathode of the klystron, causing it to emit electrons. A stream of electrons is formed and accelerated by the positive potential on the accelerator and grid cavity structure, and passes through the resonator grids 1 and 2 of the internal cavity resonator, causing an oscillation to take place in the cavity. An oscillating field is set up between the resonator grids, causing the velocity of the electrons to change as they pass through the grids. When resonator grid 2 is positive with respect to resonator grid 1, the electrons are further accelerated; when resonator grid 2 is negative with respect to resonator grid 1, the electrons are decelerated.

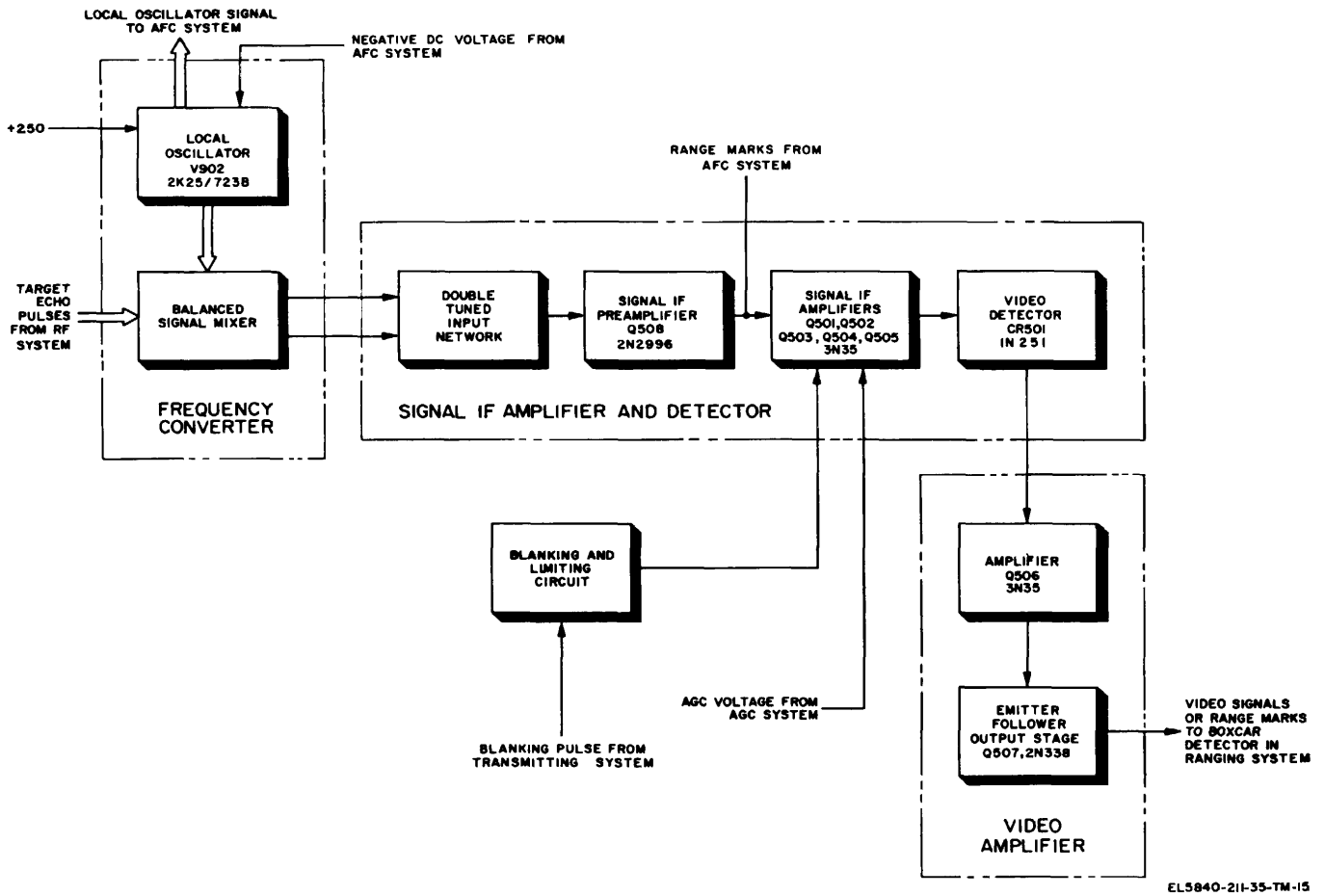

Figure 2-15. Receiving system block diagram

After the electrons pass through the resonator grids they encounter a retarding field produced by the negative voltage which is applied to the reflector cap. Those electrons which were accelerated while passing through the resonator grids travel further into the retarding field and thus have to traverse a longer path to return to the resonator grids. Those electrons which passed through the resonator grids an instant later and were decelerated, traverse a shorter path in the retarding field and thus return to the resonator grid at the same time as the accelerated electrons. In this manner the electrons are formed into bunches and deliver energy to the oscillating field within the internal cavity resonator as they pass through it. The energy delivered by the bunches is taken from the klystron cavity by means of a loop coupling, through a coaxial output probe. The frequency of oscillation is influenced mainly by the size of the cavity resonator and, to a lesser extent, by the value of the negative reflector voltage.

c. Coarse tuning of the klystron is accomplished by turning the tuning knob (fig. 2-16) on the tube which will vary the size of the cavity resonator. Turning the tuning knob in a counterclockwise direction compresses the tuner bow on the side of the tube and increases the spacing between the walls of the cavity resonator grids. Increasing the spacing between the walls of the internal cavity resonator decreases the capacitance of the cavity and increases the resonant frequency. Fine tuning of the klystron is accomplished by changing the reflector voltage. The negative voltage on the reflector determines the transit time of the electrons between the first passage and their return passage through the grids of the internal cavity resonator. Making the reflector more negative decreases the transit time and increases the frequency. The power output of a type 2K25/723B klystron drops to one half power (3-db point) when the reflector voltage varies the frequency approximately 25 MHz from the natural resonant frequency of the cavity resonator. This corresponds to a change in reflector voltage of approximately 10 volts. Potentiometer R632 (para 2-46c) in the afc search and control circuit of the afc system varies the reflector voltage from -70 to -145 volts which, together with the coarse tuning control on the klystron, covers the tuning range from 8, 900 to 9, 400 MHz.

d. The accelerator grid (pin 1) of local oscillator V902 (fig. 2-17) is connected to +250 volts. The electrostatic field between the cathode (pin

8) and the accelerator grid, internally connected to the resonator grids, accelerates electrons emitted by the cathode. The output of the klystron is coupled to the waveguide assembly by a coaxial output probe extending through pin 4 of the tube base. The waveguide assembly conducts the RF energy to the signal and afc mixers. The klystron power level at the mixers can be adjusted by the local oscillator attenuator to the narrow wall of hybrid waveguide assembly No. 2. Capacitor C901 provides a low impedance path to ground for any RF signals and prevents them from reaching the reflector of local oscillator V902.

e. The balanced signal mixer (fig. 2-18), consisting of signal mixer crystals CR901 and CR902 and portions of hybrid waveguide assemblies Nos. 1 and 2, mixes the target echo pulses with the RF output of local oscillator V902 to produce an IF output of 30 MHz. The balanced signal mixer utilizes two separate mixer channels in order to help cancel noise generated by local oscillator V902.

f. The operation of the balanced signal mix is illustrated in figure 2-18. The relative phase angles d of the vectors are indicated as Le in the figure. Other symbols used are: target echo pulse (E), local oscillator signal (LO), 30-MHz IF signal (IF), and local oscillator noise (N). The local oscillator signal LO Le and local oscillator noise, N Le enter hybrid waveguide assembly No. 2 and undergo a 3-db split in energy and a 90-degree phase shift at the coupling aperture. The target echo pulse, E Le also undergoes a 3-

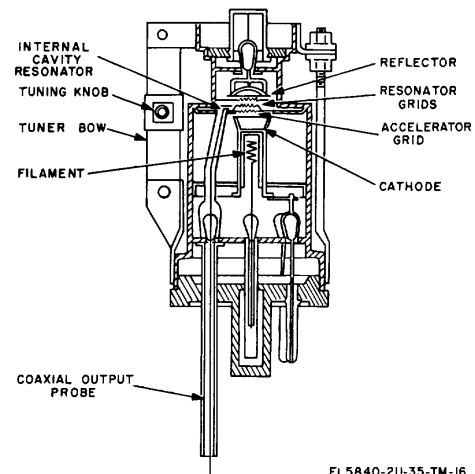

Figure 2-16. Local oscillator V902, cutaway view.

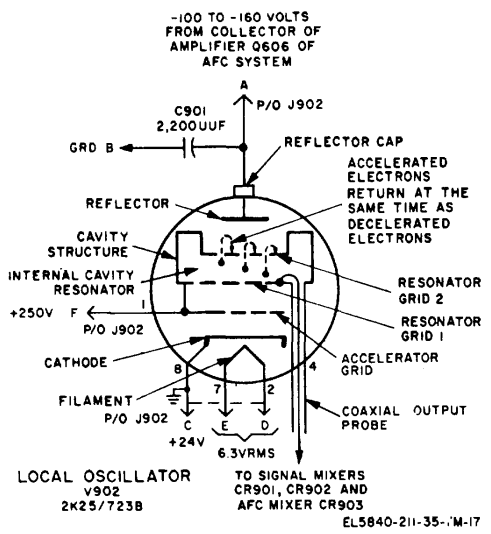

Figure 2-17. Local oscillator V902, simplified schematic diagram

2-34. Signal IF Preamplifier Q508 (fig. 7-7)

db split in energy and is shifted in phase by 90 degrees. The local oscillator signal and target echo pulse are mixed at signal mixer crystals CR901 and CR902. Since the local oscillator frequency is 30 MHz higher in frequency than the target echo pulse, the output of the signal mixer crystals will be a 30-MHz IF signal. In addition, since signal mixer crystal CR902 (1N23ER) is reversed in polarity with respect to signal mixer crystal CR901 (1N23E), the IF signal components of the signal mixer current will be in phase. Since the local oscillator noise is mixed with the local oscillator and target echo pulse in the signal mixers, the noise components of the signal mixer output will be 180 degrees out of phase. These signals are routed through short lengths of coaxial cable to signal IF preamplifier Q508 of the signal IF amplifier and detector. Since the IF signal components of the signal mixer current are in phase they will add at the input of signal IF preamplifier Q508 while the noise components will cancel due to their phase difference of 180 degrees.

2-34. Signal IF Preamplifier Q508 (fig. 7-7)

a. General. The sensitivity of the receiving system is determined largely by the amount of noise generated within the components of the re

ceiving system. The amount of noise generated in the input stages is of particular concern because of the low-level signals to be amplified by these stages. The input stage of the signal IF amplifier is made solid state to reduce the filamentary losses of the radar set. A diffused base mesa germanium transistor, having a low noise figure and high gain, is used in the input stage. Transistor Q508 is a type 2N2996 transistor.

b. Signal IF Preamplifier.

(1) The 30-MHz IF signals from the balanced signal mixer are summed through capacitors C501 and C502 to a common point on one side of inductor L541. The noise components of the balanced mixer output are 180 degrees out of phase and will therefore cancel when they appear at this common point. Provision is made for measuring the dc component of the crystal current for test and alignment purposes by connecting a millimeter to jack J506 or J507. The crystal current filter networks, consisting of L501, L502, L511, C503, C504, C549 and L503, L504, L513, C505, C506, C550, prevent the 30-MHz IF signal from reaching the meter, and also prevent any stray pickup by the meter leads from reaching the input circuit and causing oscillations. During normal operation, the outputs of the crystal current filter networks are grounded; when the crystal current is to be measured, the output is grounded through jack J506 or J507 and the meter.

(2) The 30-MHz IF signal output appearing at the junction of capacitors C501 and C502 is coupled to the base of signal IF preamplifier Q508 by a double-tuned input network which consists of inductors L507 and L541 and capacitors C574 and C553. The network is the equivalent of a transformer which matches the low output impedance of the signal mixer crystals to the input impedance of signal IF preamplifier Q508. Trimmer capacitor C553 is included in the network to adjust for variation in signal coupling. This network is adjusted to provide the required gain and bandwidth characteristics at the output of the signal IF preamplifier.

(3) Signal IF preamplifier Q508 amplifies the 30-MHz IF signal applied to the base and develops an amplified 30-MHz IF signal across collector load inductor L510, which resonates with collector capacitance of signal IF preamplifier Q508 at 30 MHz. The amplified signals developed at the collector of signal IF preamplifier Q508 are coupled through capacitor C513 to the base of succeeding IF amplifier Q501.

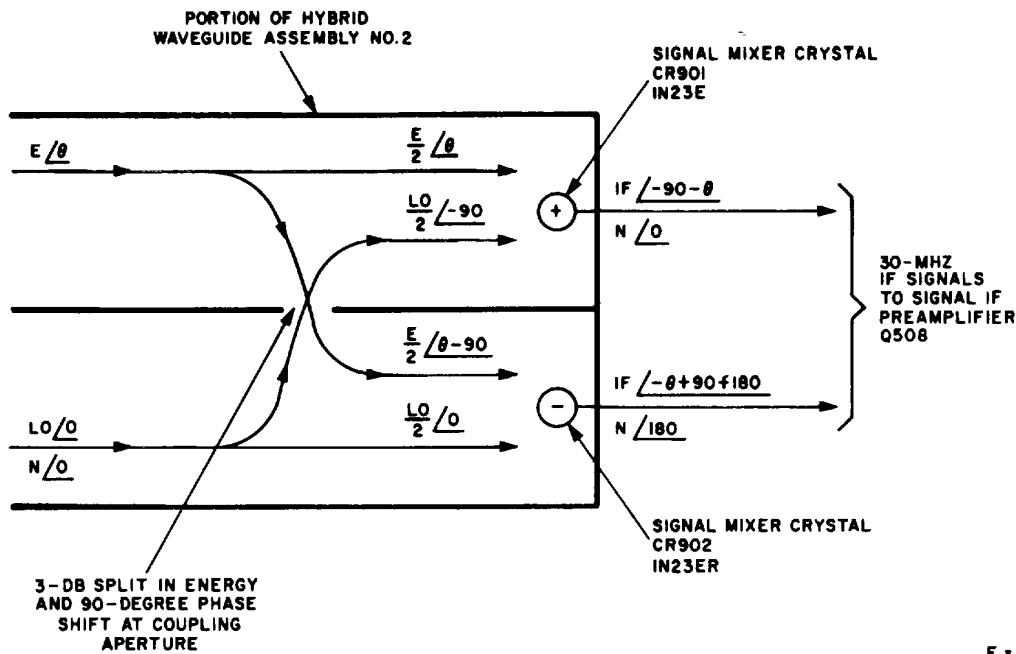

Figure 2-18. Balanced signal mixer, function

(4) The emitter bias for signal IF preamplifier Q508 is developed across resistor R552, by-passed by capacitor C588. Decoupling network L542, L543, C589, C590, and C591' isolates the IF signals of IF preamplifier Q508 from the + 24- volt power source. Resistor R553 is in parallel with collector load inductor LI510 to lower the "Q" of the inductor to minimize the possibility of oscillation. Resistors R550 and R551 are in series from +24 volts to ground. This voltage divider provides a bias to the base of IF preamplifier Q508. Capacitor C592 is provided to ac couple the input network of L507, L541, 0574, and C553 to the base of IF preamplifier Q508.

2-35. Signal IF Amplifiers Q501 through Q505

a. *General.* The five signal IF amplifiers are type 3N35 tetrode transistors and each is connected in a common emitter configuration. The interstage coupling networks between stages are capacitance coupled, double-tuned networks. The collector circuit voltage for each stage is decoupled through inductance-capacitance networks. This decoupling is provided between stages and the +20-volt power source. The emit

ter circuit voltage for each stage is supplied through resistance-capacitance networks from the -20-volt power source:

(1) When POWER switch S101 (fig. 7-13) is in the TRANSMIT position, the signal applied to base No. 1 of signal IF amplifier Q501 is the IF signal from signal IF preamplifier Q508. When POWER switch S101 is in the RANGE position, the signal applied to base No. 1 of signal IF amplifier Q501 consists of the 30-MHz range marks from the afc system coupled through capacitor C569.

(2) An agc voltage is applied from the agc system to the emitter of signal IF amplifier Q501 and to base No. 2 of all the signal IF amplifiers Q501 through Q505 in order to vary their gain as the input level changes. This prevents saturation of the amplifiers when large signals are applied and also provides a means of presenting a visual indication on the RANGE EXTENSION METERS meter when a target is gated. Resistors R546 and RT501 (thermistor) stabilize the gain with temperature changes by causing the agc voltage to vary slightly with temperature.

(3) The limiting and blanking circuit for signal IF amplifiers Q501 through Q503 is covered in paragraph 2-38.

b. Signal IF Amplifier Q501. Signal IF amplifier Q501 amplifies the 30-MHz input IF signals applied to base No. 1 and develops 30-MHz output IF signals across the interstage network consisting of inductors L522 and L535 and capacitors C515 and C570.

(1) The collector voltage is supplied from the +24-volt power through collector load inductor L522, and through the decoupling network (*a* above). Resistor R523 drops the incoming +24 volts to approximately +20 volts (which is the voltage at the collector of Q501 since only a negligible dc voltage drop is caused by the inductors).

(2) The emitter bias is developed across emitter resistor R503 and the series network consisting of resistors R506, R509, R513, R517, R521 and R546, in parallel with RT501, in the age voltage line. The emitter is returned to ac ground through bypass capacitor C514.

(3) The base 2 bias is developed across resistor R505 and the resistor network on the age voltage line. Base 2 is returned to ac ground through bypass capacitor C516. Inductor L514 serves as a high impedance path to ground for the RF input to base No. 1 of Q501 and has a low dc resistance for the emitter to base saturation current.

(4) Inductor L51-5 and capacitor C518 form a decoupling network which isolates the +20-volt line ((1) above) from IF signals on the collector of signal IF amplifier Q501 and also isolates the collector of signal IF amplifier Q502 from the collector of Q501. Similarly, resistor R506 and capacitor C539 form a decoupling network which isolates the agc voltage line from IF signals on the emitter and base 2 of Q501, and also isolates base 2 of Q502 from the emitter and base 2 of Q501.

c. Signal IF Amplifiers Q502 Through Q505. The discussion of signal IF amplifier Q501 is applicable to signal IF amplifiers Q502 through Q505 with the following additions:

(1) The emitter bias for signal IF amplifiers Q502 through Q505 is developed across the emitter resistor of each amplifier and the resistor network in the -20-volt collector supply.

(2) In addition to the 3, 300-microfarad bypass capacitors C555, C520, C527, and C529, the emitters of signal IF amplifiers Q502 through Q504 are bypassed by

1-microfarad capacitors C554, C556, and C557. The emitter of signal IF amplifier Q505 is bypassed with capacitor C5'58 which has a value of 40 microfarads. These capacitors maintain a constant emitter bias level for large input pulses, preventing the signal IF amplifiers from blocking after the pulses are removed.

(3) One-microfarad capacitors C561, C562, C559, and C531 are placed in parallel with the collector decoupling capacitors of signal IF amplifiers Q502, Q503, Q504, and Q505 to maintain the collector power supply voltage at a constant level.

d. Interstage Coupling Network. The double-tuned, interstage coupling network is shown in figure 7-7. The primary circuit of the interstage network consists of inductor L522 and output capacitance of signal IF amplifier Q501. The secondary circuit consists of inductor L53'5, and the series combination of capacitor C570 and the input capacitance C_{in} of signal IF amplifier Q502. The circuits are capacity-coupled by capacitor C515 and effectively loaded on one side only by the input resistance R_{in} of signal IF amplifier Q502. The values of inductors L522 and L535 and of capacitors C51, 5 and C570 are chosen to give the interstage network transitional coupling a bandwidth of approximately 10 MHz. The resultant bandwidth of the entire IF amplifier is approximately 6 MHz.

2-36. Video Detector (fig. 7-7)

a. Video detector CR501 in the signal IF amplifier and detector circuit demodulates the 30-MHz IF signals and produces video signals. The output produced is the envelope of the amplified 30-MHz IF signal.

b. The 30-MHz output from the collector of the last signal IF amplifier stage Q505 is coupled by capacitor C533 and inductor L521' to video detector CR501. The combination of inductors L526 and L521, and capacitor C560 forms a double-tuned network. Video detector CR501' conducts during positive signal excursions producing a rectified output current. A low-pass filter, consisting of capacitors C566, C567, and C568, inductors L533 and L534, and resistors R533, R534, and R504, filters the 30-MHz component of the rectified output. The resulting signals obtained across load resistor R524 consist of positive video signals which are routed to amplifier Q506 of the video amplifier.

2-37. Video Amplifier

a. Amplifier Q506 amplifies the detected video signals and/or range marks, and develops the amplified signals across the load impedance, consisting of inductor L140, capacitor C677, and resistors R525 and R530. The parallel combination of inductor L540 and capacitor 0577 forms a video peaking circuit which increases the high frequency response to obtain the required video bandwidth. The low frequency response is maintained by dc coupling between stages.

b. The emitter bias for amplifier Q506 is developed across resistors R528 and R531. Resistor R528 is bypassed by capacitor C535 to provide a low impedance path to ground for the video signals. Resistor R531 is left unbypassed in the emitter circuit to obtain some negative feedback. The base No. 2 bias is developed across resistor R529 which is bypassed by parallel capacitors C638 and 0585 to provide a low impedance path for the video and 30 MHz signals. Capacitor C534 and inductor L520 form a decoupling network which provides the necessary decoupling between IF amplifier Q506 and the other IF amplifier stages.

c. Limiting is required to prevent an excessive signal output of amplifier Q506 from passing through emitter follower output stage Q507 to the .boxcar detector in the ranging system, and causing the diodes in the boxcar detector to conduct upon reception of a signal from a large ungated target. Limiting is accomplished by fixing the collector emitter bias of amplifier Q506 at a value which will allow the amplifier to be limited for large input pulses and will limit the input to emitter follower output stage Q507 to approximately + 3.5 volts. d. Emitter follower output stage Q507 isolates the video load at output jack J502 from the collector of video amplifier Q506, and matches the input impedance of the ranging system. e. The output signal from the collector of amplifier Q506 is fed to the base of emitter follower output stage Q507. The output signal from Q507 is developed across emitter resistor R527. Resistor R523, capacitor C536, and paralleled capacitors C548 and 0563 form a decoupling network which provides the necessary decoupling for the +24 volt power supply. To limit the power dissipation of emitter follower output stage Q507, dropping resistor R526 and bypassing capacitor C537 are placed in the collector circuit to provide a low impedance path to ground for video signals.

2-38. Blanking and Limiting Circuit (fig. 7 7)

a. *General.* The purpose of the blanking and limiting circuit is to prevent the signal IF amplifiers from becoming over loaded and saturated due to leakage of the transmitted RF pulses through the dual channel limiter and into the balanced mixer.

b. Circuit Functioning.

(1) When the magnetron fires, a negative blanking pulse is developed in pulse unit Z201 of the transmitting system and is coupled via a coaxial cable to plug P508 of the IF amplifier unit. The blanking pulse is coupled through resistor R642 to diode CR507 which has a fixed bias obtained across capacitor C584. That part of the blanking pulse more negative than the diode bias therefore appears across diode load resistor R543, and is coupled through capacitor C582 to a voltage divider consisting of resistors R540, R541, and R544.

(2) The pulse which appears across resistor RP540 is applied to diodes CR502, CR503, CR504, and CR505. These diodes are normally back biased at approximately 0.5 volt which is developed across resistor R540 by applying +24 volts to the voltage divider formed by R544, R541, and R640. The back bias prevents possible conduction of diodes CR502 through CR505 when RF signals are applied, and permits the IF signals to pass through the signal IF amplifier stages. This bias is overcome by the negative blanking pulse which appears across resistor IR640 when the magnetron fires, so that these diodes conduct and a low impedance shunt is presented across the tuned circuits of stages Q508, Q501, Q502, and Q503, through the respective diodes and capacitors C582 and C584, thus effectively shorting the IF signal to ground. circuit components without reference designations, two 100 ohm resistors, one 2, 200 ohm resistor, one 470 , Acf capacitor, and one crystal diode 1N127A are used to eliminate objectionable noise pulses which may develop and blank out the target signals after 300 hours of radar set service.

NOTE

The above components are mounted in the blanking pulse subchassis. Inductor L541 has been removed.

(3) Each diode presents an impedance to its respective amplifier stage and this impedance decreases as the forward current increases; therefore, limiting is provided on large amplitude signals (after the reverse bias voltage has been overcome).

Section VI. AUTOMATIC FREQUENCY CONTROL SYSTEM FUNCTION

2-39. General

a. The automatic frequency control (afc) system maintains the receiving system local oscillator frequency at 30 MHz above the output frequency of the transmitting system so that the 30-MHz tuned circuits of the signal IF amplifiers in the receiving system can operate at maximum efficiency. Automatic frequency control of the local oscillator is accomplished by mixing the local oscillator signal and a sample of the magnetron output pulse of the transmitting system. The resultant difference frequency signal is amplified and fed to a discriminator circuit which produces a pulse error signal having an amplitude which is a function of the difference frequency. This pulse error signal is amplified and converted into a negative dc voltage which controls the local oscillator frequency and maintains the difference frequency at 30 MHz.

b. The relationship of the afc system with respect to the other functional systems of the radar set is covered in paragraph 2-13.

2-40. System Block Diagram Discussion (fig. 2-19)

a. *Afc Mixer.* Afc mixer CR903 mixes the signal from local oscillator V902 with the attenuated magnetron pulses from the afc coupler in the RF system to produce a pulsed IF signal which is applied to the afc IF amplifiers. The frequency of this signal is the difference between the frequencies of the local oscillator and the magnetron.

b. *Afc IF Amplifiers.* Afc IF amplifiers Q701 and Q702 amplify the pulsed IF signal from the afc mixer and feed the amplified signal to delay line DL701 in the precision range mark generating circuit and to the afc discriminator.

c. *Afc Discriminator.* The afc discriminator, consisting of a network of passive elements, produces a pulse error signal having an amplitude which is a function of the frequency of the IF signal from the afc IF amplifiers. The afc discriminator produces zero output for input signals having a frequency of approximately 29 MHz, positive video pulses for input signals of less than 29 MHz, and negative video pulses for input signals of greater than 29 MHz.

d. *Afc Video Amplifier Circuit.* The afc video amplifier circuit consists of emitter follower Q703 and amplifiers Q704 and Q705. The afc video amplifier circuit amplifies the negative video pulses from the afc discriminator and feeds

them to the afc search and control circuit. Positive video pulses do not pass through the afc video amplifier circuit.

e. *Afc Search and Control Circuit.* The afc search and control circuit consists of detector circuit C708, CR603, and R625; amplifiers Q607 and Q606; and relaxation oscillator CR608. The afc search and control circuit converts the amplified negative video pulses from the afc video amplifier circuit into a dc voltage which is directly coupled to the reflector of local oscillator V902 thereby controlling the local oscillator frequency. When no negative video pulses are received from the afc video amplifier, relaxation oscillator CR608 produces a sweep voltage on the reflector of local oscillator V902 which sweeps the klystron frequency, increasing it slowly and decreasing it rapidly approximately five times each second.

f. *Precision Rangemark Generating Circuit.* The precision rangemark generating circuit consists of delay line DL701 and relay K701. The input signal to this circuit is the amplified IF signal from the afc IF amplifiers. Delay line DL701 generates 30-MHz pulses which are used as a means of calibration of the RANGE METERS indicator when POWER switch S101 (fig. 7-13) is in the RANGE position. This position of the POWER switch operates relay K701 causing it to apply the range marks to the signal IF amplifiers of the receiving system.

2-41. Afc Mixer

Afc mixer CR903 is a type 1N23C crystal which is mounted within hybrid waveguide assembly No. 2 (fig. 2-12). High power magnetron pulses from the transmitting system are attenuated by the afc attenuator in the RF system and coupled to the afc system by the afc coupler. The attenuated magnetron pulses are mixed with the signal from local oscillator V902 in afc mixer crystal CR903. The output of the afc mixer are 0.2-microsecond pulses of IF energy having a frequency which is the difference between the local oscillator and magnetron frequencies. These pulsed IF signals are applied to the afc IF amplifiers.

2-42. Afc IF Amplifiers

a. *General.* The afc IF amplifiers are two identical common emitter tetrode stages, Q701 and Q702, connected by a single-tuned interstage coupling network.

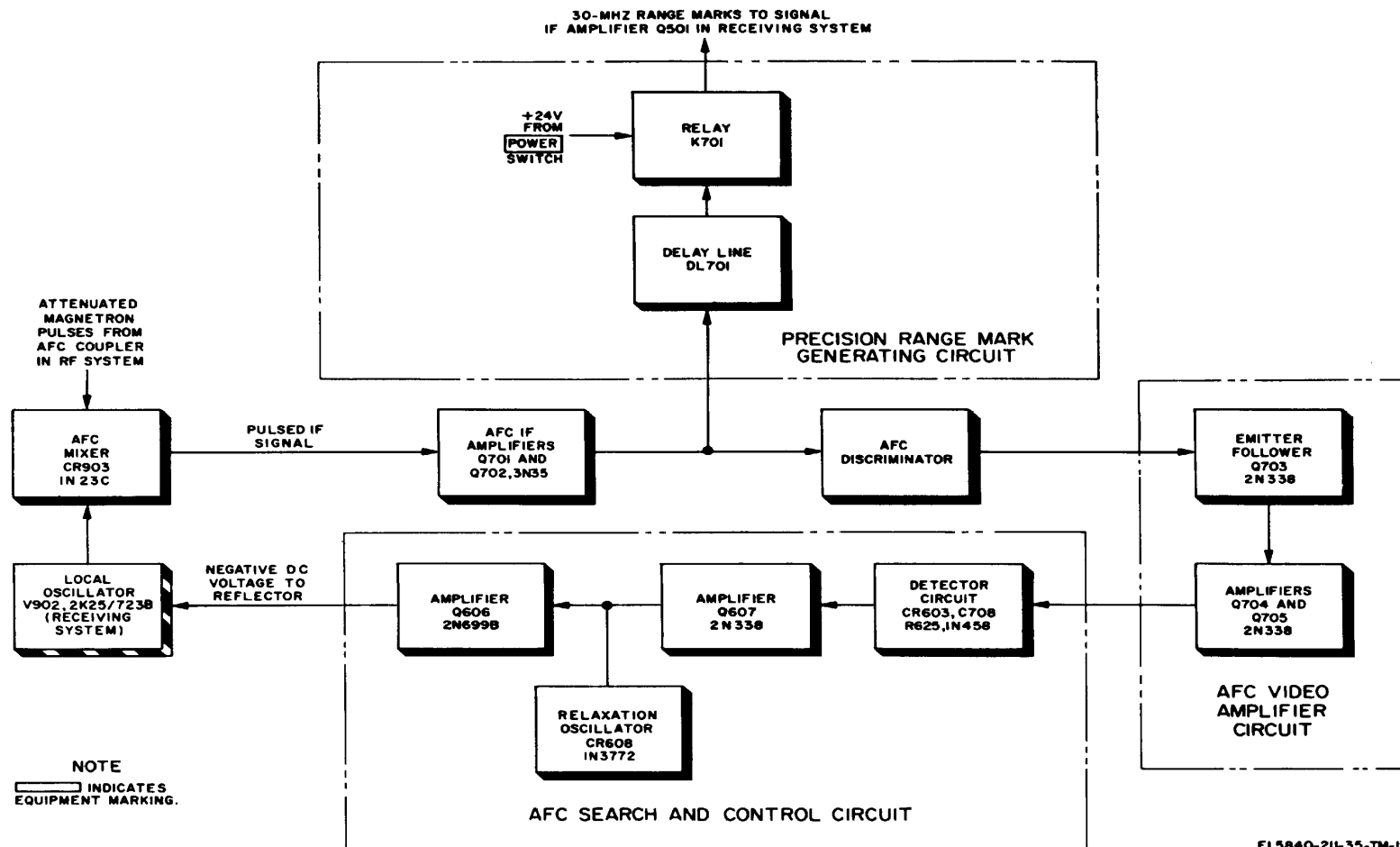

EL5840-211-35-TM-19

Figure 2-19. Afc system block diagram

b. Operation (fig. 7-8).

(1) The pulsed IF input signals to afc IF amplifiers Q701 and Q702 are the signals from afc mixer crystal CR903 which is coupled to base No. 1 (b1) of afc IF amplifier Q701 through a single-tuned network. The single-tuned network is resonant at 30 MHz and consists of the capacitance of the crystal holder and the capacitance of the coaxial cable connected in parallel with inductor L1701. The pulsed IF signals are amplified by afc IF amplifier Q701 and are fed to afc IF amplifier Q702 through a single-tuned inter-stage coupling network. This network, consisting of variable load inductor L702, input capacitor C706, and the collector-to-ground capacitance of transistor Q701 is tuned to resonate at 30 MHz. The IF signals are further amplified by afc IF amplifier Q702 and are fed directly to the afc discriminator, and also are coupled to delay line DL701 through coupling capacitor C705.

(2) The forward bias for afc IF amplifier Q701 is obtained by connecting base No. 1 (b1) to ground through inductor L701, and the emitter to -20 volts through resistor R701. Resistor R701 is bypassed to ground by capacitor C702. The reverse bias for base No. 2 (b2) of transistor Q701 is obtained by connecting base No. 2 (b2) to -20 volts through resistor R702 which is bypassed to ground by capacitor C704. Inductor L703 and capacitor C701 form a decoupling network which isolates the +24-volt power supply from the IF signals on the collector of transistor Q701, and also isolates the collector of transistor Q701 from the collector of transistor Q702. The forward bias for transistor Q702 is obtained by connecting base No. 1 (b1) to ground through inductor L706 and connecting the emitter to -20 volts through resistor R703 which is bypassed to ground by capacitor C709. The reverse bias for base No. 2 (b2) of transistor Q702 is obtained by connecting base No. 2 (b2) to -20 volts through resistor R704 which is bypassed to ground by capacitor C710. Inductor L705 and capacitor C703 form a decoupling network which isolates the +24-volt power supply from the IF signals on the collector of transistor Q702. Capacitor C717 prevents spurious oscillations resulting from large input signals from being passed to the afc discriminator. The output of afc IF amplifier Q702 is developed across variable load inductor L704 and is fed directly to the afc discriminator. A portion of the output signal of afc IF amplifier Q702 is coupled through capacitor C705 to delay line DL701.

a. General. The IF pulses from afc IF amplifier Q702 are applied to the afc discriminator at the junction of capacitors C711 and C712. Capacitors C711 and C712, together with inductor L707, form a circuit which determines the voltage which appears across diode CR702 (E2) and across diode CR701 (E,). The afc discriminator produces zero output for input signals having a frequency of approximately 29 MHz; positive video pulses for input signals of less than 29 MHz; and negative video pulses for signals of greater than 29 MHz (fig. 2-20).

b. Operation With Continuous Wave Input. The network consisting of capacitors C711 and C712 and inductor L707 can be considered as part of two series resonant circuits. One of these circuits consists of capacitors C711, C712, and C721; inductor L707, the interelectrode capacitance of diodes CR701 and CR704, and the wiring capacitance. This circuit is resonant below 30 MHz. The other circuit consists of capacitors C711, C712, and C720; inductor L707, the interelectrode capacitance of diodes CR702 and CR705, and the wiring capacitance. This circuit is resonant above 30 MHz. Thus, if a continuous

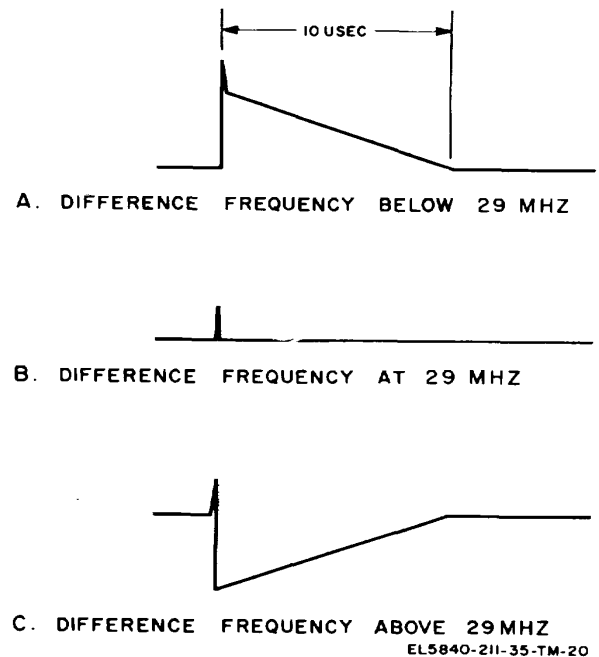

Figure 2-20. Afc discriminator output pulse

wave input signal having a frequency below 30 MHz is applied to the afc discriminator, this frequency is nearer the resonant frequency of the first series resonant circuit than the resonant frequency of the second series resonant circuit. Under these conditions E_1 , the output signal of the first series resonant circuit, will exceed E_2 , the output signal of the second series resonant circuit. If the applied signal has a frequency above 30 MHz, this frequency is nearer the resonant frequency of the second series resonant circuit and E_2 will in turn be larger than E_1 . The output signal E_1 is detected by diode CR701 and capacitor C714 and produces a charge on capacitor C714. The output signal E_2 is detected by diode CR702 and capacitor C713, and produces a charge on capacitor C713 of the polarity indicated in figure 7-8. The net charge on capacitors C713 and C714 constitutes the output voltage of the afc discriminator. If E_1 exceeds E_2 , the net charge on capacitors C713 and C714 will be positive; if E_2 is larger than E_1 , then the net charge on the capacitors will be negative; if E_1 and E_2 are equal, the net charge on the capacitors is zero. The result of this discriminator action for a continuous wave input is shown by the discriminator response, the solid curve in figure 2-21.

c. *Normal Operation.* In normal operation, the signal applied to the afc discriminator consists of 0.2 microsecond modulated IF pulses from the afc IF amplifiers rather than a continuous wave signal. With this pulsed input, the output consists of video pulses rather than a continuous wave. Due to the short duration of the IF pulses, the output voltages (E_1 and E_2) of the two series resonant circuits do not have sufficient time to reach their maximum values and as a result the IF pulses applied to the afc discriminator (E) are larger than the output voltages (E_1 and E_2). During the negative half-

cycle of the input voltage (E), both capacitors C713 and C714 are charged through diode CR702 in such a way that the junction of CR702, C713, and R720 is negative with respect to the junction of C713 and C714, and the junction of C713 and C714 is negative with respect to ground; during the positive half-cycle of voltage E only C714 will be charged positive with respect to ground through diodes CR704 and CR705. As a result, a net negative charge remains on the capacitor even when the two output voltages (E_1 and E_2) are equal. The entire discriminator response for continuous wave operation is shifted negatively and becomes the new response for the pulsed input (dashed curve, fig. 2-21). The dashed curve represents the locus of the peaks of the afc discriminator video output pulses as the frequency of the IF input pulses varies. For proper operation of the afc system, a negative afc discriminator video output pulse of 0.1 to 0.3 volt is required at the desired IF frequency. As a result the discriminator is normally tuned to obtain this value at 30 MHz. The afc discriminator video output pulses are applied to the afc video amplifier circuit.

(1) Resistors R705 and R706 form a virtual center tap for inductor L707. Capacitors C720 and C721, in conjunction with diodes CR704 and CR705, form a voltage doubler circuit for voltages developed across inductor L707. The voltage doubling is obtained as a result of the charging of capacitors C720 and C721 through diodes CR704 and CR705, respectively, during alternate half-cycles, and the discharging of capacitors C720 and C721 through diodes CR702 and CR701, respectively, during the intervening half-cycles. This action causes the voltages on capacitors C720 and C721 to be added to the voltage

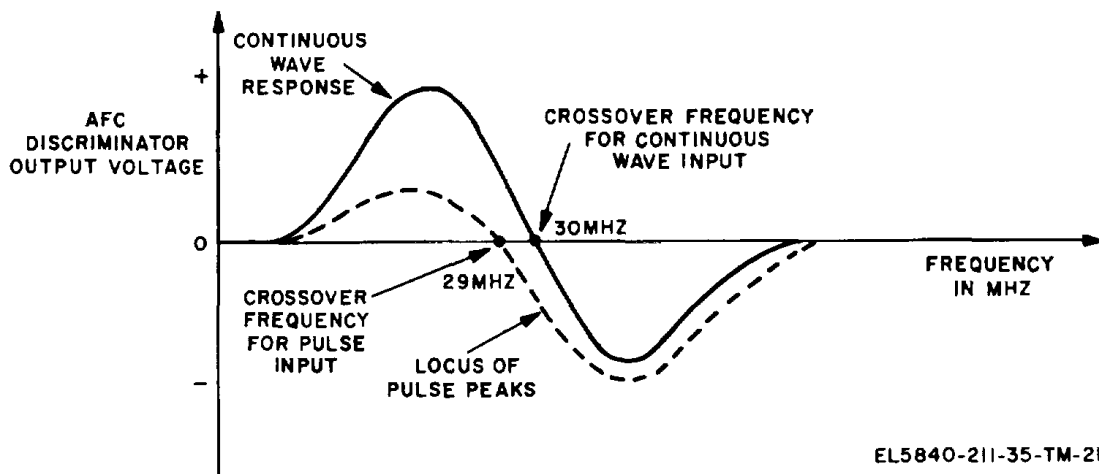

Figure 2-21. Afc discriminator response

developed across inductor L707 during each half-cycle.

(2) The four diodes of the afc discriminator are forward-biased by resistor R720 which is connected to +24 volts, and resistor R722 which is connected to -20 volts. The diodes are forward-biased in order to avoid loss of that portion of the signal which would otherwise be required to overcome the forward conduction voltage of the diodes. Resistor R721 functions as a lead for the afc discriminator, thereby tending to minimize the effects of environmental changes in the characteristics of emitter follower Q703 in the afc video amplifier circuit.

2-44. Afc Video Amplifier Circuit (fig. 7-8)

a. General. The afc video amplifier circuit consists of emitter follower Q703 and amplifiers Q704 and Q705. Emitter follower Q703, the input stage, presents a high impedance to the afc discriminator. Amplifier Q704 is biased so that it is in a conducting state at all times. Amplifier Q705 is biased in its cutoff region so that only positive video pulses will forward bias transistor Q705 and be amplified. Therefore, only negative video pulses will appear at the output of amplifier Q705, corresponding to afc discriminator input pulses of greater than 29 MHz.

b. Operation. The video input pulses are coupled by capacitor C715 to the base of emitter follower Q703. Resistor R707 provides forward bias for emitter follower Q703. The video output pulses of emitter follower Q703 are developed across resistor R710 and are coupled through an rc network, consisting of capacitor C716 and resistors R711 and R712, to the base of amplifier Q704. Amplifier Q704 is forward-biased by the network consisting of resistors R711, R712, R719, and R714. Resistor R714 is bypassed by capacitor C719 to prevent excessive degeneration. Resistor R719 stabilizes the gain, and resistor R714 stabilizes the operating point of amplifier Q704. Depending upon the polarity of the input pulses, amplifier Q704 develops either positive or negative video pulses across load resistor R713. These video pulses are coupled through capacitor C707 to the base of amplifier Q705. Amplifier Q705 is biased below cutoff by returning the base and the emitter to ground through resistors R715 and R717, respectively. As a result, amplifier Q705 amplifies positive input pulses and remains cut off during negative input pulses. Therefore, only negative pulses are developed across load resistor R716. The output pulses are coupled through capacitor C708 to the detector circuit of the afc search and control

circuit in the audio unit. Emitter resistor R717 provides degeneration to stabilize the gain of amplifier Q705.

2-45. Afc Search and Control Circuit (fig. 7-11)

a. General. The afc search and control circuit consists of two direct-coupled amplifier stages and a relaxation oscillator which are operated at a reference voltage of -150 volts so as to be compatible with the negative dc voltage required by the klystron reflector of local oscillator V902. The first stage consists of amplifier Q607 which is biased in its cutoff region so that no current flows in the amplifier without an input signal. Relaxation oscillator CR608 consists of a four-layer diode (type 1N3772) with a capacitor connected to its anode. The output of relaxation oscillator CR608 is a positive-going sawtooth voltage at the anode of the four-layer diode. The second amplifier stage consists of amplifier Q606, which is forward-biased so that it conducts at all times. The collector of amplifier Q606 is directly connected to the klystron reflector of local oscillator V902 in the receiving system.

b. Relaxation Oscillator CR608.

(1) Relaxation oscillator CR608 is a two-terminal four-layer diode which has a negative resistance characteristic. This characteristic permits its application as a relaxation oscillator. A more detailed description of a four-layer diode can be found in paragraph 2-18e.

(2) When the anode voltages, V_A , is less than 20 volts, the four-layer diode is reverse-biased and only a small leakage current will flow through it. Capacitor C610, therefore, charges through the network consisting of resistors R628, R636, R631, and R633, and the voltage, V_A , rises exponentially. When V_A reaches 20 volts, an avalanche effect occurs causing a sudden buildup of current through relaxation oscillator CR608. Capacitor C610, therefore, discharges rapidly through the small resistance of the four-layer diode, and resistor R629, and V_A drops rapidly to 1 volt. As soon as the discharge current reaches a low value, the holding current value, capacitor C610 starts charging again, and the cycle is repeated so that a saw tooth oscillation is generated at the anode. Resistors R628 and R631 and capacitor C610 are the principal elements that determine the frequency of the saw-tooth oscillation which is approximately 5 Hz.

c. Circuit Functioning.

(1) With no input signal from amplifier

Q705 in the afc video amplifier circuit, amplifier Q607 is cut off. The positive-going saw-tooth input of relaxation oscillator CR608 is amplified by amplifier Q606 so that a negative-going saw-tooth voltage is impressed on the klystron reflector of local oscillator V902, forcing an increase in the output frequency of V902. This results in a saw-tooth modulation of the frequency of the local oscillator signal which covers the local oscillator dynamic tuning range.

(2) When the increasing output frequency of local oscillator V902 passes through a frequency which is 30 MHz above the frequency of magnetron V901, negative video pulses will be developed at the output of amplifier Q705 in the afc video amplifier circuit. These negative video pulses discharge capacitor C708 (fig. 7-8) through diode CR603 (fig. 7-11) and, in the periods between pulses, the capacitor discharges through the path formed by resistors R71, 6 (fig. 7-8), R625 (fig. 7-11), R627 and input resistance of amplifier Q607. The charge time constant is large so that amplifier Q607 is held in the conducting state during the entire period between pulses, thereby producing the required dc output level at the collector of amplifier Q607. If amplifier Q607 conducts sufficiently to lower the voltage at the anode of four-layer diode CR608 below 20 volts, the saw-tooth oscillation will be discontinued. The afc search and control circuit then acts as a normal two-stage dc amplifier, amplifying the voltage input at the base of amplifier Q607, and feeding it to the klystron reflector of local oscillator V902 from the collector of amplifier Q606.

(3) If the difference frequency signals rise above 30 MHz, the negative video pulses from the afc discriminator increase in amplitude, thereby decreasing the negative dc voltage output of the afc search and control circuit which is applied to the klystron reflector of local oscillator V902. This change in reflector voltage decreases the local oscillator output frequency in order to maintain the difference frequency at 30 MHz. If the difference frequency signals fall below 30 MHz, the negative video pulses from the afc discriminator decrease in amplitude, thereby increasing the negative dc output from the afc search and control circuit. This change, in turn, increases the local oscillator output frequency. When the local oscillator frequency is increased sufficiently to obtain 30-MHz difference frequency signals, the negative video pulses of the afc discriminator are just large enough to prevent any further change in the reflector voltage, that is,

lock-on occurs. This action of the afc search and control circuit maintains the difference frequency at 30 MHz.

(4) Resistors R628, R630, R631, R633, and R636 and potentiometer R632 form the collector load for amplifier Q607 and the bias network for amplifier Q606. Resistors R629 and R639 stabilize the operating point and gain of stages Q607 and Q606. Potentiometer R632 adjusts the negative voltage to the klystron reflector of klystron local oscillator V902 to cover the tuning range of 8, 930 to 9, 430 MHz. Diode CR607 compensates for temperature-caused changes in the base-to-emitter voltage drop of amplifier Q606.

(5) AFC/MFC switch S601, located on the audio unit, provides a means of manually adjusting the reflector voltage of the klystron local oscillator for alignment purposes. By placing the switch in the MFC position, the input voltage to amplifier Q606 is held fixed at a point midway between the limits of the saw-tooth oscillation. With the switch in this position the quiescent reflector voltage (and hence the klystron frequency) may be adjusted to obtain a 30-MHz difference frequency by varying potentiometer R632. This procedure insures that the saw-tooth oscillation of the local oscillator frequency is centered about the 30-MHz difference frequency.

2-46. Precision Range mark Generating Circuit

a. *General*, Delay line DL701 receives the amplified pulsed IF signal from afc IF amplifiers Q701 and Q702 through coupling capacitor C705 and produces precision range marks to calibrate the RANGE, METERS indicator and thereby insure a range accuracy of ± 25 meters. Calibration is necessary to offset any changes in the slope of the linear sweep of the ranging system caused by temperature. The RANGE position of the POWER switch operates relay K701 located in the afc unit with +24 volts, and this relay connects the precision range marks from the output of delay line DL701 to the signal IF amplifiers in the receiving system. At the same time, operated relay K701 removes the +24 volt source from the emitter and the base of signal IF preamplifier Q50S, thereby disabling the preamplifier and preventing target echo signals from passing through the receiving system. The precision range marks, which are spaced to simulate target returns from approximately 500, 1, 500, 2, 500, 3, 500, 4, 500, 6, 500, 6, 500, and 7, 500 meters, are amplified by the signal IF amplifiers as though they were large fixed target returns. The amplified range-

marks are then routed to the ranging system through the video detector (para 2-36) and the video amplifier (para 2-37) of the receiving system. Diode CR706 is included to help suppress voltage transients from winding of K701 which cause fuses to blow in the system.

b. Operation.

(1) Delay line DL701 (fig. 222) is a hermetically sealed unit containing a quartz delay rod with piezoelectric crystals attached to each end. When the 30-MHz IF pulse is fed from afc IF amplifier Q702 to delay line DL701, the pulse excites the input crystal of DL701 and causes the crystal to propagate the pulse through the quartz delay rod to the output crystal where it appears as a 30-MHz pulse at the output crystal. The first output pulse is delayed in time by the delay of the line which, in this case, is the equivalent time of a roundtrip of radar energy from a target at 500 meters range (approx. 3.33 microseconds). A portion of the energy from the first input pulse is reflected by the output crystal back through the delay line to the input crystal where it is again reflected. This reflected energy is converted to a second 30-MHz output pulse by the output crystal. This second output pulse is separated

from the first output pulse by twice the delay of the line, or approximately 1, 000 meters. This process of reflection occurs repeatedly, thereby producing output pulses equivalent to target echoes received from targets at approximately 500, 1, 500, 2, 500, 3, 500, 4, 500, 5, 500, 6, 500, and 7, 500 meter ranges. Losses within the delay line cause successive pulses to be reduced in amplitude. This output train of pulses is applied through contacts 1 and 6 of operated relay K701 (fig. 7-8) to base No. 1 of signal IF amplifier Q501 in the receiving system. Capacitor C718 bypasses to ground any inductive transients formed when relay K701 is restored.

(2) The precision range marks are furnished only when relay K701 is energized by placing POWER switch S101 in the RANGE position. In this position, in addition to application of range marks, the +24-volt supply is disconnected from the plates of signal IF preamplifier Q508 in the receiving system by; relay K701, so that the target echo signals are not present at signal amplifier Q501 when the 30-MHz range mark pulses from delay line DL701 are applied.

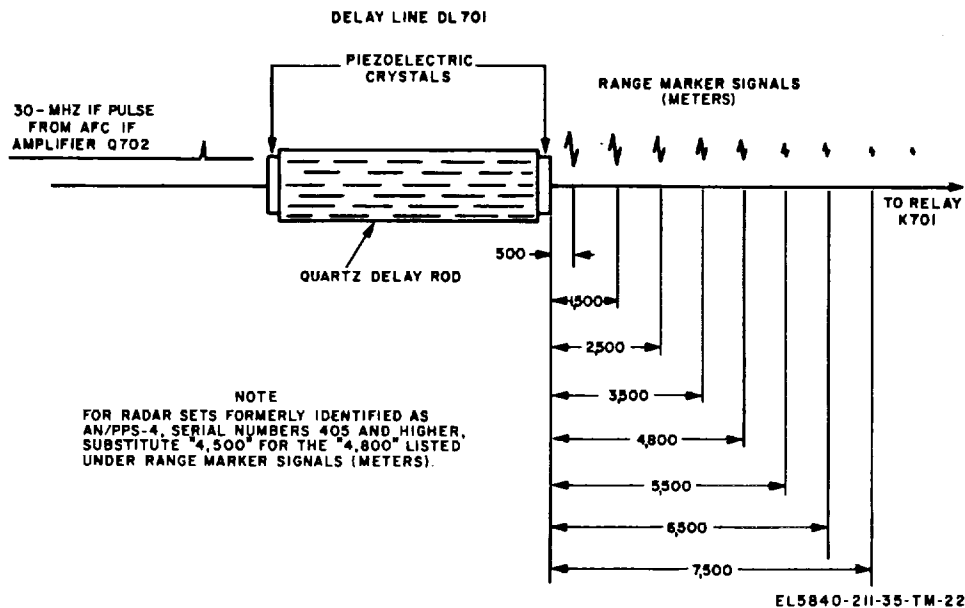

Figure 2-22. Delay line DL701, functional schematic diagram

Section VII. RANGING SYSTEM FUNCTION

2-47. General

a. The ranging system gates the video return signals so that video from only a certain 30-meter range increment will be detected. The position of the 30-meter range increment is determined by the RANGE

CONTROL handwheel on the control panel. The output of the ranging system is obtained from peak detecting (stretching) video signals synchronized with the range gate. This output is fed to the audio and afc systems.

b. The relationship of the ranging system with respect to other functional systems of the radar set is covered in -paragraph 2-13.

2-48. System Block Diagram (fig. 2-23)

a. *Linear Sweep Circuit.* The linear sweep circuit consists of linear sweep switch Q401 and linear sweep generator Q402 and Q403. Linear sweep switch Q401 is switched by the negative gate from the transmitting system. This negative gate begins at the same time as the transmitted pulse and is turned off just after the multiar pulse is generated. Linear sweep switch Q401 energizes the linear sweep generator which remains energized for the duration of the negative gate. The linear sweep generator produces a linear sweep (varying from 0 to 53 microseconds in length and from 0 to 45 volts in amplitude) which is coupled to the comparator circuit.

b. *Strobe Circuit.* The strobe circuit consists of relaxation oscillator CR1002, double emitter follower Q1001 and Q1002, and a voltage divider. The circuit has three modes of operation: long strobe, short strobe, and strobe off or normal. In both the long and short strobe modes, the strobe circuit provides an automatic strobing (scanning) of the range gate; in both modes, the range gate strobes through a range of 500 meters, beginning with the setting on the RANGE METERS indicator, and then quickly returns to the range indicated on the RANGE METERS indicator to repeat the strobe cycle. In the long strobe mode, the period of the +2 to -1.4-volt saw-tooth sweep is approximately 10 seconds; in the short strobe mode, the period is approximately 5 seconds. In the normal mode, the strobe circuit produces a steady dc voltage of approximately 2 volts. The age voltage from the afc system is fed to the strobe circuit and summed with the strobe voltage to indicate the presence of a target on RANGE EXTENSION METERS meter M101. The strobe voltage is fed to the comparator circuit.

c. *Comparator Circuit.* The comparator circuit consists of pickoff circuit C406, CR411, and multiar Q404, T401. Pickoff diode CR411 in the comparator circuit will not conduct the linear sweep to the multiar until the linear sweep voltage exceeds the range voltage from potentiometer R103 which reverse-biases pickoff diode CR411. The output of the strobe circuit is fed to the comparator circuit and regulates the time that it will take for the linear sweep voltage to rise to the value of the range voltage. In the long and short strobe modes,

as the strobe output becomes more negative, the linear sweep takes a longer time to rise to the value of the range voltage. Therefore, there is a longer time interval between the beginning of the linear sweep and the beginning of conduction by pickoff diode CR411. When pickoff diode CR411 conducts, a pulse of approximately 1.8-microsecond duration is generated by multiar Q404 and transformer T401 and coupled by the output winding of the transformer to the differentiating circuit in the range gate circuit. The pulse is also coupled by the output winding to the transmitting system where the negative overshoot of the multiar pulse turns off the negative gate from the transmitting system. The time delay between the beginning of the linear sweep and the beginning of conduction by pickoff diode CR411 is proportional to the range of the range gate; as the strobe voltage increases negatively, the range of the range gate increases, and there is an automatic range strobing effect.

d. *Range Gate Circuit.* The range gate circuit consists of differentiating circuit C410, R416 narrows the multiar pulse in order to avoid multiple triggers. The positive differentiated multiar pulse triggers blocking oscillator Q405 which produces a range gate that has an amplitude of approximately 10 volts and a duration of 0.2 microsecond. Transformer T402 couples the gate to the detector circuit.

e. *Detector Circuit.* The detector circuit consists of boxcar detectors CR413, CR414, C418, R424, and double emitter follower Q406, Q407. Video signals from the video amplifier in the receiving system are also fed to the boxcar detector when the POWER switch is at TRANSMIT. When the POWER switch is at RANGE, range-marks replace the video signals. The video signals (or range marks) which coincide with the range gate are "stretched" or peak-detected by capacitor C418 and resistor R424 to obtain the peak amplitude of each video signal. When only a fixed target is present, the video amplitude will be constant and a constant dc voltage will be developed across capacitor C418. If a moving target as well as a fixed target is present, the video amplitude will vary with each video signal and a boxcar detector voltage, with a wave form similar to that illustrated in figure 2-23, will be developed across capacitor C418. The voltage across capacitor C418 is fed through double emitter follower Q406, Q407 to the audio and age systems.

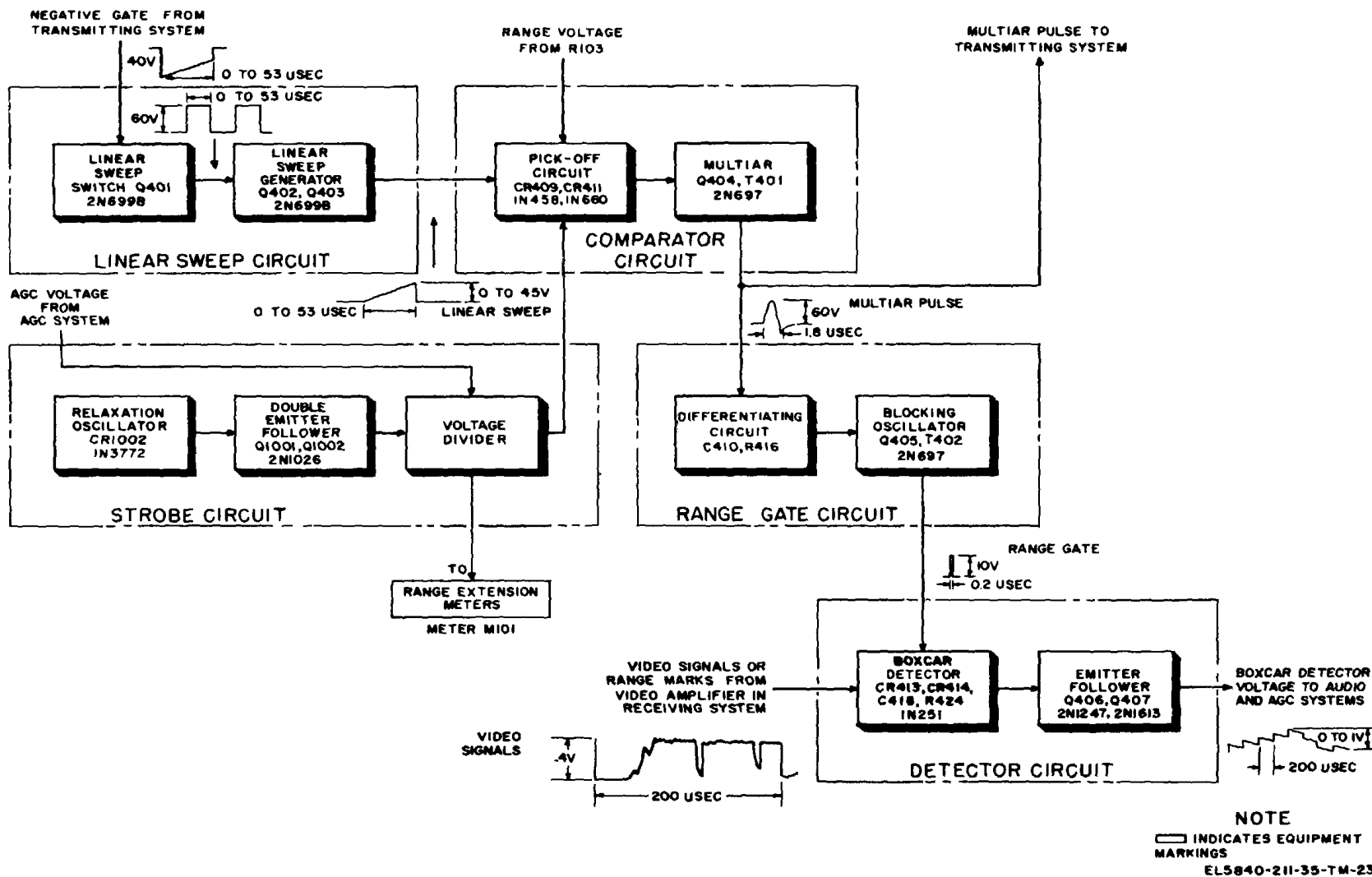

Figure 2-23. Ranging system block diagram

2-49. Linear Sweep Circuit (fig. 7-9)

a. Diodes CR405 and CR417 in the linear sweep circuit are Zener diodes. A Zener diode has the property of maintaining a constant voltage across itself regardless of the current through it (up to the maximum rating of the diode) once it has been sufficiently reverse-biased to pass the Zener breakdown point and to conduct in the Zener region (fig. 2-24). Diodes CR405 and CR417 are 30-volt Zener diodes; that is, they reach the Zener breakdown point when approximately 30 volts of reverse bias are applied across each of them.

b. Before the negative gate from the transmitting system enters the linear sweep circuit, the conditions listed in (1) through (5) below are present.

(1) Linear sweep switch Q401 is switched on (in full conduction). Electrons flow from -2 volts through voltage divider R407 and R428 to ground to provide an emitter bias; and through resistor R407, from the emitter to the base of linear sweep switch Q401, through diode CR402, and resistor R401 to +24 volts, placing linear sweep switch Q401 in full conduction. The impedance of resistor R401, diode CR402, and resistor R402 prevents linear sweep switch Q401 from saturating in order for it to have faster turn off time. Diode CR403 is not conducting.

(2) Since linear sweep switch Q401 is in full conduction, electrons also flow from the emitter to the collector of Q401, through collector load, resistor R404, through current-limiting resistor R405 to +120 volts. Electrons also flow through diode CR406, resistor R409, and diode CR415 to +60 volts. Capacitors C416 and C404 are uncharged since linear sweep switch Q401 is in full conduction and diode CR407 prevents the voltage on these capacitors from going below ground.

(3) The reverse bias developed across Zener diodes CR405 and CR417 by electron flow through resistor R405 causes the diodes to reach the Zener breakdown point and to conduct in the Zener region. Because of this, the voltage at the junction of diode CR417 and resistor R404 remains at +60 volts. Sixty volts is tapped off at this point for use in the bootstrap emitter follower Q402 circuit of the linear sweep generator, and in the strobe unit. Capacitor C401 decouples any RF ripple from the +60 volts.

(4) Bootstrap emitter follower Q402 in the linear sweep generator is always conducting because it is forward-biased; its base never goes below ground, and its emitter impedance (constant current generator Q403 and resistor R412) is connected to the -20-volt supply. Voltage divider R403 and R411 provides a base voltage

for constant current generator Q403. Capacitor C403 and voltage divider R403 and R411 filter and provide a constant base voltage. Constant current generator Q403 in the linear sweep generator is operated under conditions whereby a constant base current (I_b) provides a constant collector current (I_c) even though the collector voltage (V_c) increases (fig. 2-25).

(5) Electrons flow from the collector of constant current generator Q403 to capacitor C405 and through diode CR415 to +60 volts which charges capacitor C405 to 60 volts.

c. When the negative gate from the transmitting system enters the linear sweep circuit through pin L of jack J401 and plug P401, the conditions listed below occur.

(1) Diode CR402 is reverse-biased by the negative gate and electron current flow through linear sweep switch Q401 stops, cutting off Q401. Capacitor C402 couples the negative gate to the base of Q401 to hasten cutoff. Linear sweep switch Q401 is reverse-biased by the -20-volt supply in order to keep it at cutoff. Diode CR403 limits the base-to-emitter voltage of Q401 to the forward voltage drop of diode CR403, approximately 0.5 volt. This prevents reverse breakdown of the base-to-emitter junction of Q401. Resistor R402 limits the amount of current following through diode CR403.

(2) When linear sweep switch Q401 cuts off, its collector rises to approximately +60 volts and reverse-biases diode CR406 to cutoff.

(3) When diode CR406 cuts off, capacitors C416 and C404 charge toward 60 volts through resistors R409, R410, and diode CR415. The charging time constant is determined by the values of resistors R409, R410, and capacitors C416, C404. To obtain a linear increase in voltage with respect to time on a capacitor, the electron current flow charging the capacitor must be constant. Bootstrap emitter follower Q402 is used to obtain a constant charging electron current flow for capacitor C416 and C404, and therefore a linear voltage rise at the base of bootstrap emitter follower Q402. The dc voltage developed at the junction of resistors R409 and R410 determines the base current of bootstrap emitter follower Q402 which develops a voltage at its emitter identical to the voltage developed at its base. The voltage developed at the emitter of bootstrap emitter follower Q402 is fed back via capacitor C405 to be added to the +60-volt charge.

ing source of capacitors C416 and C404. Therefore, as the sweep voltage increases on the emitter of bootstrap emitter follower Q402, the voltage on capacitor C405 increases. Diode CR415 cuts off when the voltage on capacitor C405 rises above 60 volts. In this manner, the increasing sweep at the emitter of bootstrap emitter follower Q402 is coupled to the more positive side of resistor R409. Therefore, both ends of resistor R409 rise in voltage by the same amount, and the voltage across resistor R409 remains essentially constant. As a result, the electron current flow through resistor R409 is constant, capacitors C416 and C404 charge linearly, and a linear sweep (fig. 2-23) appears at the emitter of bootstrap emitter follower Q402.

(4) Electron current flow from the emitter through the base of bootstrap emitter follower Q402 to capacitors C416 and C404 must be kept relatively constant so that it does not affect the linear sweep voltage. This electron current flow is kept constant by constant current generator Q403 which is provided with constant base current (I_B) and, because of its characteristics (fig. 2-25), supplies constant collector current (I_C). Therefore, an increase in the linear sweep voltage at the collector of constant current generator Q403 produces only a negligible increase in the collector current of Q403 and electron current flow from the emitter through the base of bootstrap emitter follower Q402 is kept relatively constant.

d. When the negative overshoot of a multiar pulse from the ranging system is applied to the emitter follower (Q201) stage, the action of the emitter follower stage will be to remove the negative gate to the linear sweep switch (Q401) stage, causing the conditions listed in (1) and (2) below to occur

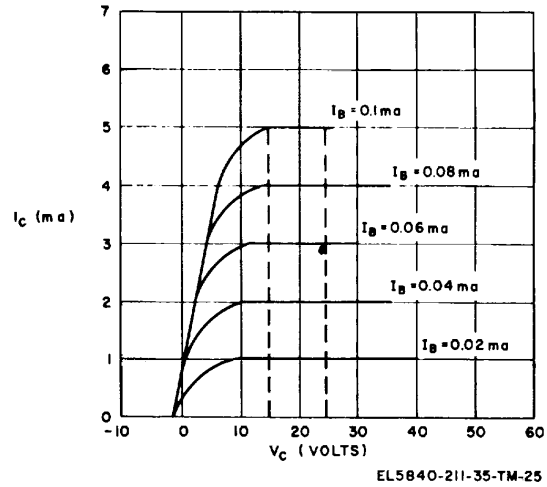

Figure 2-25. Constant current generator Q403, characteristic curve

(1) Diode CR402 is forward-biased by +24 volts, linear sweep switch Q401 begins to conduct again, the conditions listed in b above occur, and the cycle repeats.

(2) Capacitors C416 and C404 discharge through resistor R410, diode CR406, linear sweep switch Q401, and resistor R407. Diode CR407 prevents the voltage on capacitors C416 and C404 from going below ground.

e. The linear sweep developed at the emitter of bootstrap emitter follower Q402 is coupled to the comparator circuit.

2-50. Strobe Circuit

a. *General.* In the strobe circuit, diode CR-1002 (fig. 2-26) is a four-layer diode whose characteristics are discussed in paragraph 2-18e. Diodes CR1001 and CR1003 are Zener diodes whose properties are discussed in paragraph 2-49a. The Zener breakdown point of diode CR-1001 is reached when approximately 5 volts of reverse bias are applied across the diode. After this breakdown point is reached, the voltage drop across diode CR1001 will remain at approximately 5 volts regardless of the current passing through the diode (up to the maximum current rating of the diode). In the strobe circuit, Zener diode CR1001 is used to maintain a 5-volt drop across capacitor C1001. The Zener breakdown point of diode CR1003 is reached when a 2-volt reverse bias is applied across the diode. The 2-volt drop across diode CR1003 provides a reference voltage for the normal strobe circuit output to compensate for the voltage drop across diodes

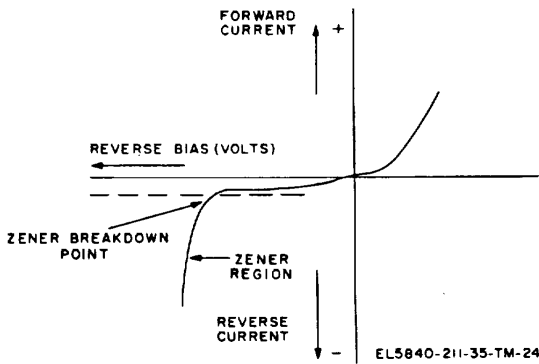

Figure 2-24. Zener diode characteristic curve

CR409 and CRP111 (fig. 7-9) in the comparator circuit (para 2--51).

b. Long Strobe Mode.

(1) When STIROIE switch S105. is set at LONG (fig. 2-26), capacitor C1001 charges very quickly through resistors R1022, R1004, and thermistor RT1002. When this charge reaches approximately 5 volts, Zener diode CR1001 becomes sufficiently reverse-biased to conduct in the Zener region, maintaining a constant 5-volt potential across capacitor C1001. Capacitors C1003 and C1004 begin to charge toward 165 volts through resistors P1022, R1001, and R1003, thermistor RT1002, and diode CR1001, producing a sweep at the base of emitter follower Q1001. Resistors R1022, R1004, and R1003, thermistor RT1002, diode CR1001, and capacitors C1003 and C1004 determine the 10-second time constant for the long strobe. The charge electron current flow for capacitor C1004 passes from resistor R1003 through pin N of plug P105 and jack J105, through STROBE switch S105, and through pin P of jack J105 and plug P105 to capacitor C1004. When the parallel combination of capacitors C1003 and C1004 is charged to approximately 15 volts, the voltage applied across four-layer diode CR1002 (the sum of the voltages across capacitor C1001 and the parallel combination of capacitors C1003 and C1004) is 20 volts, which is the switching voltage (I_h) of the diode. Four-layer diode CR1002 starts to switch to the "closed" state and will remain in this state until the current through it falls below holding current (I). When diode CR1002 switches to the "closed" state, capacitors C1003, C1004, and C1001 discharge through resistor R1003, diode CR1001, and diode CR1002; Zener diode CR1001 stops conducting in the Zener region since the diode is no longer reverse-biased and begins to conduct in the conventional way when it becomes forward-biased. Since four-layer diode CR1002 has certain pulse current limitations, resistor R1003 is used to limit the current as capacitors C1003 and C1004 discharge so that the current limitations of diode CR1002 are not exceeded. When capacitors C1003, C1004, and C1001 discharge, the current through four-layer diode CR1002 falls below the holding current (I) and the diode switches to the "open" state. Variable resistor R1004 makes it possible to adjust the charging time of capacitors C1003 and C1004. Thermistor RT1002 compensates for any changes in the capacitance of capacitors C1003 and C1004 due to temperature changes in order to maintain a constant rc time constant for the circuit. As

temperature increases, the resistance of thermistor RT1002 decreases to compensate for the increase in the capacitance of capacitors C1003 and C1004. Capacitor C1001 in conjunction with diode CR1001 ensures that the four-layer diode conducts in the negative resistance region (current increases through the four layer diode with voltage decrease) between terminals) instead of positive resistance region. The voltage across CR1001 will be equal to the voltage across capacitor C1001. Although the voltage across the four-layer diode decreases, the current through it is forced to increase.

(2) Emitter followers Q1001 and Q1002 present a very high impedance to the electron current flow from the -150 volt supply and limits electron flow to the output circuit which is connected to the emitter of emitter follower Q1002. This reduces the shunting effect of the output circuit so that the charging time constant of capacitors C1003 and C1004 is not materially affected.

(3) The sweep voltage developed across capacitors C1003 and C1004 increases the forward base to emitter bias on emitter follower Q1001, causing it to conduct. The electron current flow from emitter-follower Q1001 increases the forward base to emitter bias on emitter follower Q1002 causing it to conduct. Therefore, the sweep appears at the emitter of emitter follower Q1002. The voltage drop across resistor R1012 forward biases emitter follower Q1002.

(4) The output of the emitter followers is approximately a 10-second sweep that varies from approximately +1 to -14 volts. The output of voltage divider R1017, R1009, R1018, and R1027. is fed through pin U of plug P105 and jack J105, through switch S105, through pin 23 of plug P101 and jack S101 to the comparator circuit and through pin M of jack J10. and plug P105 to resistor R1014, through pin W of plug P105 and jack J10) to RANGE EXTENSION METERS meter M101, causing the needle on the meter to deflect from zero to approximately 500 meters over a period of 10 seconds. Variable resistor R1017 (strobe amplitude adjust) adjusts the amplitude of the output of the strobe circuit so that the needle on the RANGE EXTENSION METERS meter M101 deflects to an indication of approximately 500 meters. Potentiometer P1025 (zero adjust) adjusts the dc level of the sweep output so that the needle on RANGE EXTENSION METERS meter M101 starts deflecting from zero. Zener diode CR1003 and resistor R1013 cause RANGE EXTENSION METERS meter M101 to deflect from the same point in the long strobe, short strobe, and normal modes after

capacitors C1001, C1003, and C1004 have been discharged.

(5) Voltage divider R1015 and R1014 sums the strobe voltage with the afc voltage, which is fed in through pin 20 of jack J101 and plug P101, through pin C of jack J105 and plug P105, to capacitor C1005, so that when a target is detected the needle on RANGE EXTENSION METERS meter M101 will deflect backward due to the variation in the afc voltage.

C Short Strobe Mode. With STROBE switch S105 at SHORT (fig. 2-27), capacitor C1003 charges toward 150 volts through resistors R1004, R1022, thermistor RT1002, and diode CR1001 which determine the charging time constant of capacitor C1003. The only difference between the short and long strobe mode circuits is the elimination of capacitor C1004 from the short strobe mode circuit. The output of the short strobe mode circuit causes the needle on the RANGE EXTENSION METERS meter M101 to deflect from zero to an indication of approximately 500 meters over a period of approximately 5 seconds.

d. Normal Mode.

(1) When the STROBE switch S105 is set at OFF (fig. 2-28), resistor R1007 is connected in parallel with capacitors C1001 and C1003 and provides a discharge path for these capacitors so that they will be uncharged when STROBE S105 switch is returned to LONG or SHORT. It is necessary for capacitors C1001 and C1003 to be uncharged when STROBE switch is set at SHORT so that the short strobe sweeps will always start at zero.

(2) Reverse bias supplied for Zener diode CR1003 (fig. 2-29) from +24 volts through resistor R1013 which limits the current through the U diode. The 2.2-volt drop across diode CR1003 provides an output to the comparator circuit. This output passes through pin (V) of plug P105 and jack J105, through switch S105 to the comparator circuit. The afc voltage enters the strobe circuit through switch S105, through pin S of jack J105, and plug P105 to the junction of capacitor C1005 and resistor R1015 and is summed with the strobe voltage in the voltage divider consisting of resistors R1014 and R1015. RANGE EXTENSION METERS meter M101 indicates the sum of the afc and strobe voltages. The needle on meter M101 will deflect to approximately mid-scale, depending on the setting of VOLUME control R105, when no targets are detected. When targets are detected, the decrease in afc voltage will cause a backward deflection of the meter needle.

2-51. Comparator Circuit (Fig. 7-9.)

a. The comparator circuit is composed of pick-off circuit C406, CR411, and multiar Q404, T401. A multiar operates in a similar manner as a blocking oscillator except that the multiar has a pick-off diode in its feedback loop. The pickoff diode opens the feedback loop until the multiar is triggered. In this configuration, the multiar is very sensitive but it will not be triggered by noise.

b. Capacitor C406 couples the linear sweep voltage from linear sweep circuit Q401, Q402, Q403 through transformer T401 to pickoff diode CR411 in the comparator circuit. Diode CR411 is reverse-biased by the range voltage from potentiometer R103 through pin 48 of plug Q101 and jack J101 and pin D of jack J401 and plug P401, and therefore, does not conduct and trigger multiar Q404 through the terminals 5 and 6 winding, T401 until the linear sweep rises to a voltage which exceeds the range voltage. When the sweep exceeds the range voltage, diode CR411 conducts and triggers multiar Q404. The output multiar pulses are fed to through jack J408 and plug P408 to the transmitting system where the negative overshoot of the multiar pulse cuts off the negative gate. The multiar pulse is also applied to the local oscillator blanking circuit. The multiar pulses are also coupled to the range gate circuit to trigger the range gate. The lower the reverse bias on diode CR411, the sooner the linear sweep will cause diode CR411 to conduct, and the sooner the range gate will be generated. Therefore, the smaller the range voltage, the sooner target echoes are gated by the range gate, and the shorter the range of the detected target. In this manner, the range voltage determines the range at which targets will be gated or the position of the range gate. The range voltage is directly proportional to the setting of potentiometer R103, controlled by RANGE CONTROL handwheel.

c. The voltage from the strobe unit passes through pins T, U, or V (depending on the mode of operation) of plug P105 and jack J105, through pin 23 of plug P101 and jack J101, through pin H of jack J401 and plug P401, to resistor R406. Resistor R406 and capacitor C419 decouple any ripple from the strobe voltage. In the normal (strobe off) mode, diode CR409, biased by the strobe voltage, cuts off the negative overshoot of the linear sweep and restores the voltage level at the junction of transformer T401 and capacitor C406 to zero.

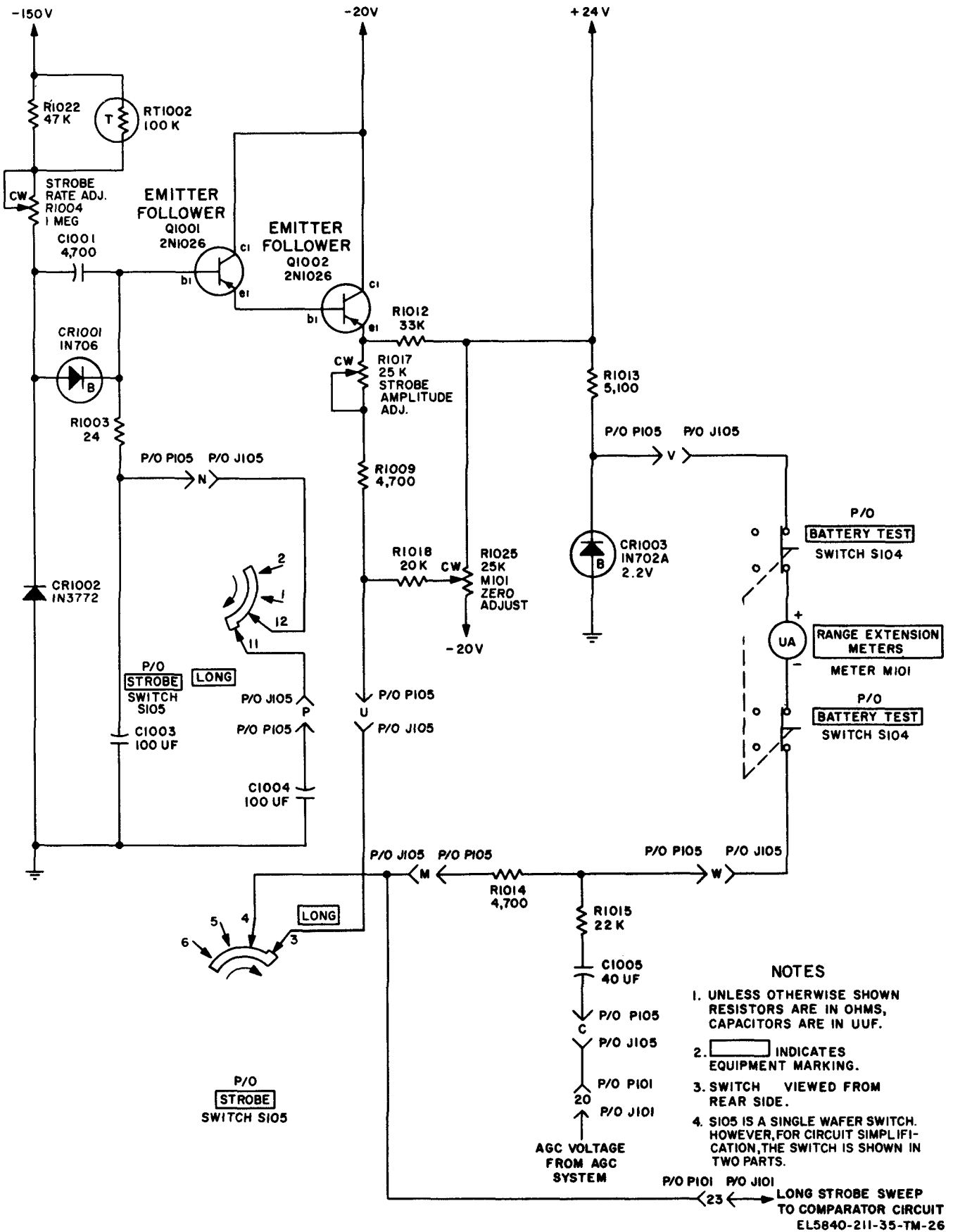

Figure 2-26. Long strobe mode, simplified schematic diagram

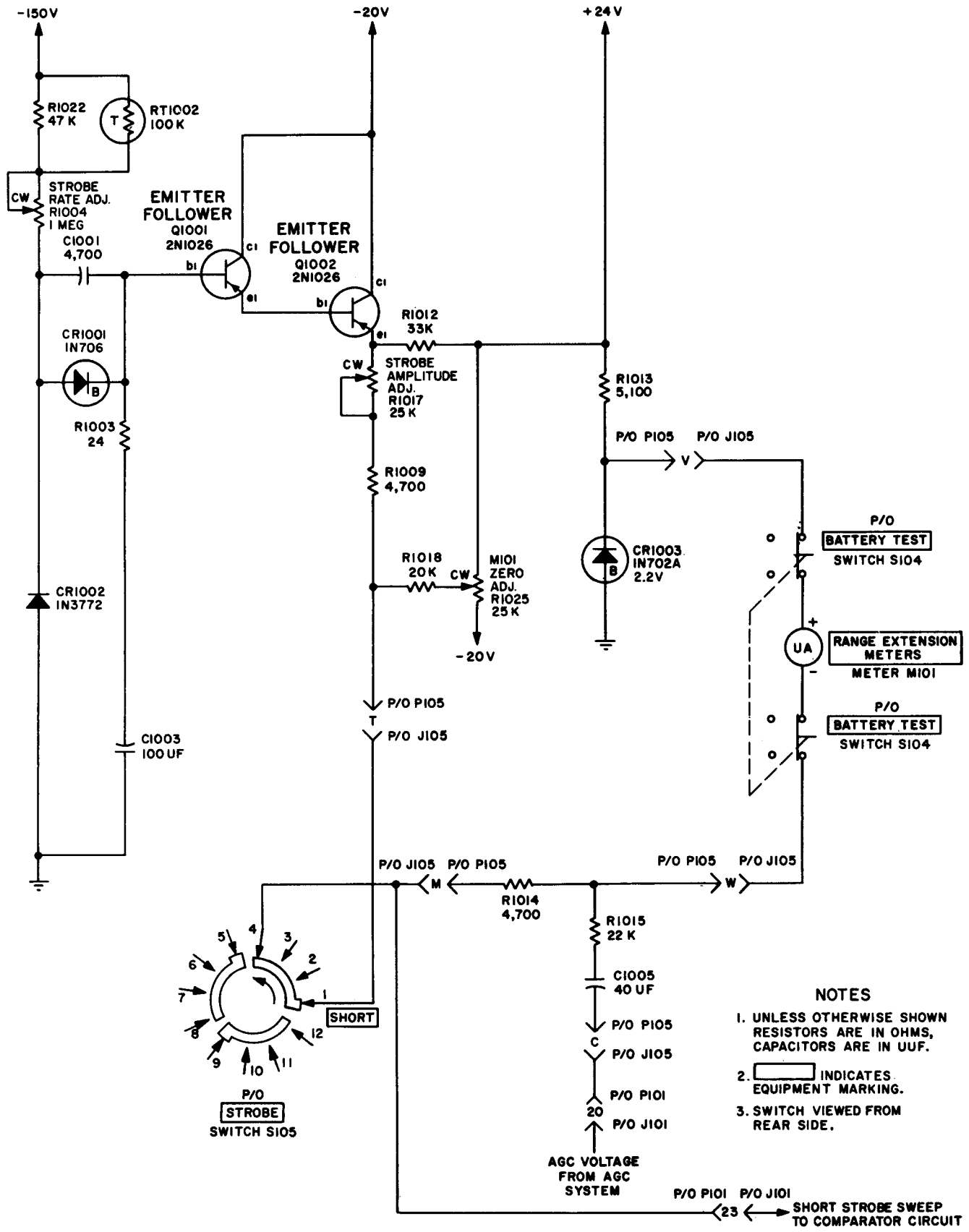

Figure 2-27. Short strobe mode, simplified schematic diagram

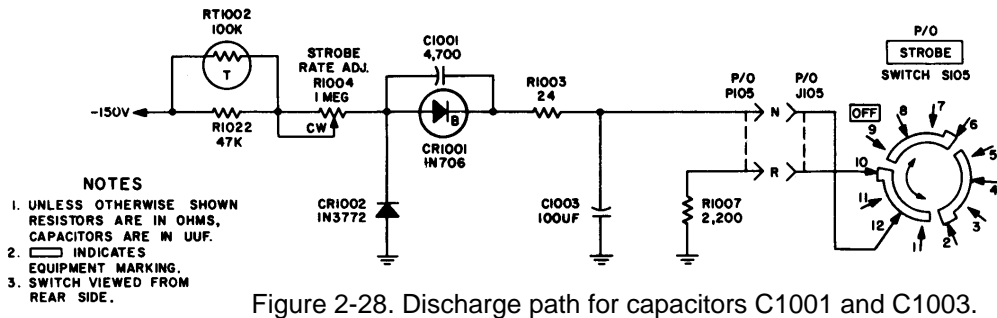

Figure 2-28. Discharge path for capacitors C1001 and C1003.

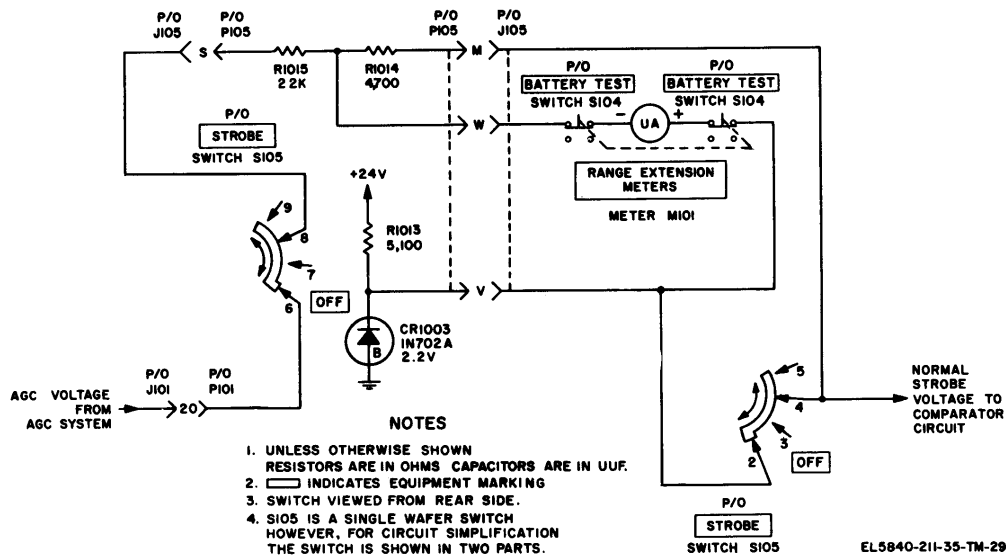

Figure 2-29. Normal mode, simplified schematic diagram.

d. The period of the long strobe is approximately 10 seconds; the period of the short strobe is approximately 5 seconds; the period of the linear sweep is usually never greater than 53 microseconds (+10%). Comparing the period of either strobe to the period of the linear sweep, the strobe voltage is essentially constant for each individual linear sweep. With each successive linear sweep, the strobe voltage appears at a more negative dc level than it did during the preceding linear sweep, and diode CR409 cuts off a smaller amount of the negative overshoot restoring capacitor C406 to a more negative voltage level. In the long and short strobe modes, the voltage level to which capacitor C406 is restored varies from 0 to approximately -3.5 volts.

e. With capacitor C406 restored to a negative voltage on the pickoff diode (CR411) side, the linear sweep starts at a negative voltage instead of zero. Therefore, it takes longer for the sweep to rise to the value of the range voltage (which remains constant for a particular setting of the RANGE CONTROL handwheel). With each successive more negative dc level of the strobe, it takes more time before the range gate will open the detector circuit to gate a target, and targets from a greater range are detected. Thus, there is an automatic strobing (scanning) of the range gate as indicated by the movement of the needle on RANGE EXTENSION METERS meter M101.

f. Resistor R413 prevents the range voltage from loading down the sweep where it is coupled into the multiar circuit. Capacitor C415 filters any ripple that is coupled through the capacitance of diode CR411.

g. Resistor R415 and capacitor C409 filter any ripple from the +24-volt supply. The electron flow through the large resistance of resistor R414 to + 24 volts, slightly forward biases multiar Q404 so that the first few tenths of a volt of the linear sweep triggers the multiar. When pickoff diode CR411 begins to conduct, the linear sweep is applied through coupling capacitor C408 to the base of multiar Q404, causing it to conduct.

h. Conduction by multiar Q404 results in electron current flow through winding 3 to 4 of transformer T401; this causes a voltage to be induced in winding 5 to 6 and winding 1 to 2. The induced voltage in winding 1 to 2 is fed to the range gate circuit and through jack J408 and plug P408 to the transmitting system. The induced voltage in winding 5 to 6 supplies regenerative feedback. The polarity of the induced voltage is such that terminal 6 is positive with respect to terminal 5, thus increasing the forward bias on multiar Q404 causing it to conduct more. This action continues until the transistor is driven into saturation and electron current flow through winding 3 to 4 ceases to increase. After saturation current flow through 3 to 4 winding becomes constant, feedback voltage is no longer induced in transformer windings 5 to 6 and 1 to 2. The base bias, provided by the sweep and the voltage across resistor R414, is not sufficient to keep multiar Q404 in saturation. Electron current flow through winding 3 to 4 decreases, and the voltage induced (in winding 5 to 6 and winding 1 to 2) is in the reverse direction making terminal 2 negative with respect to terminal 1 and terminal 6 negative with respect to terminal 5. As transistor Q201 in the transmitter unit (fig. 7-6) conducts, it provides a low impedance across the terminals 1 and 2 winding on the negative overshoot of this pulse, and this damps out the overshoot. The negative voltage at terminal 6 cuts off multiar Q404 and charges capacitor C408 to hold off multiar Q404 for the duration of the linear sweep so that there is only one multiar pulse per linear sweep.

2-52. Range Gate Circuit

(fig. 7-9)

a. Capacitor C410 couples the multiar pulse from the comparator circuit to the base of blocking oscillator Q405 in the range gate circuit. Be-

fore the multiar pulse triggers blocking oscillator Q405,

the transistor is held at cutoff by the zero bias established by returning the base to the emitter through the low value of resistance of resistor R416.

b. The blocking oscillator Q405 output pulse is only 0.2-microsecond wide. Since the multiar pulse is 1.8 microsecond wide, it must be differentiated to avoid triggering blocking oscillator Q405 more than once. Capacitor C410 and resistor R416 differentiate the multiar pulse. The differentiated positive pulse is applied to the base of blocking oscillator Q405, causing it to conduct. Electron flow through the primary winding of transformer T402 (terminals 2 to 1) produces a change in magnetic flux that induces a negative voltage across the secondary winding (terminals 3 and 4). This negative voltage on the secondary of transformer T402 forward biases blocking oscillator Q405 so that it conducts more. This action continues until Q405 is driven into saturation and electron flow ceases to increase. -Since electron flow becomes constant after saturation, the voltage induced in the secondary winding (terminals 3 to 4) falls to zero and blocking oscillator Q405 is cut off. When electron flow stops, the collapsing field around the secondary winding (terminals 3 to 4) induces a voltage in the primary winding (terminals 2 to 1) which is shunted to ground by diode CR412. During the time the flux in transformer T402 is collapsing, the voltage induced across the winding connected to terminals 1 and 2 is series aiding the applied voltage (+24 volts). This series aiding voltage is applied to diode CR412 so that it conducts in the forward direction and shunts the induced voltage. This prevents the circuit from generating a "punch through" voltage that would damage Q405.

c. Resistor R417 and capacitor C411 decouple the ripple output of blocking oscillator Q405 from the common +24-volt supply. The output of the blocking oscillator, the range gate, is transformed to the tertiary winding (terminals 5 to 6) of transformer T402, and is routed to the boxcar detector of the detector circuit.

2-53. Detector Circuit

(fig. 7-9)

a. The output of blocking oscillator Q405 on winding 5 to 6 of transformer T402 is used as a range gate to gate video at a range determined by the setting of the RANGE CONTROL hand-wheel.

b. The pulse developed on the secondary winding of T402 is approximately 20 volts. Voltage divider R422 and R423 is connected across tertiary winding 5 to 6 of transformer T402 so that the center tap of the winding is effectively at the same voltage as the junction of resistors R422 and R423. This arrangement causes one-half of the 20-volt amplitude of the pulse on the secondary winding to appear across resistor R422 and the other half across resistor R423.

c. With no video entering the boxcar detector of the detector circuit, the junction of resistors R422 and R423 is at 0 volt. When the range gate is developed on winding 5 to 6, a 10-volt drop appears across resistor R422 and a 10-volt drop appears across resistor R423. Pin 5 is positive with respect to pin 6. As the gate rises, the voltage across resistors R422 and R423 forward biases diodes CR413 and CR414, causing them to conduct, and allowing the range gate to charge capacitors C412 and C413. Resistors R418 and R419 present an impedance to the charging current so that capacitors C412 and C413 do not charge immediately to the peak of the blocking oscillator pulse, and therefore, a peak on the gate does not occur and the top of the gate is flat. The gate must be flat as it charges capacitors C412 and C413 in order to gate all the video that would fall within the width of the gate. Since the range gate is equal in amplitude on both capacitor C412 and C413, diodes CR413 and CR414 will conduct an equal amount, the junction of diodes CR413 and CR414 will remain at 0 volt, and no voltage will appear on capacitor C418. When the gate begins to fall off, diodes CR413 and CR414 are reverse-biased due to the charge on capacitors C412 and C413, and therefore, the capacitors cannot discharge through the diodes. Between range gates, approximately 1 volt is discharged by capacitors C412 and C413 through resistors R420 and R421, respectively, so that diodes CR413 and CR414 will conduct on the next range gate. With the capacitors now charged to approximately 9 volts, the next 10-volt range gate will overcome the charge on capacitors C412 and C413 and cause diodes CR413 and CR414 to conduct an equal amount.

d. Video signals (or rangemarks) pass from the video amplifier through jack J502 and plug P502 in the receiving system, through plug P407

and jack J407 in, the ranging system, and are coupled by capacitor C417 to the boxcar detector. Diode CR408 and resistor R408 restore the positive excursions of the video signals to ground potential. The negative video signals pass to the junction of resistors R422 and R423 which provide a virtual center tap for winding 5-6 of transformer T402. The negative video signals, that are coincident with the range gate, appear across diodes CR413 and CR414. Since diodes CR414 and CR413 conduct equally, the voltage at the junction of diodes CR413 and CR414 is equal to the voltage at the junction of resistors R422 and R423, which is the voltage of the detected video signal or -4 volts in this case. Capacitor C418 charges to a voltage that is proportional to the voltage of the video signal. When a moving target is detected, the video signals are of varying amplitude because they have been amplitude modulated at an audio rate due to the doppler effect; therefore, the voltage on capacitor C418 will vary in amplitude at an audio rate. Resistor R424 and capacitor C418 "stretch" or hold this voltage from one gate to another. Emitter followers Q406 and Q407 presents a high impedance and prevents any voltage leak from capacitor C418. Emitter follower Q406 is forward-biased by the voltage across resistors R427 and R425.

e. When a video signal does not coincide with the range gate, a voltage drop, equal in amplitude to the video signal, is developed across resistor R422 and across resistor R423. Since the maximum amplitude of the video signal is 4 volts, the voltage across resistors R422 and R423 is not sufficient to overcome the 9-volt charge (c above) on capacitors C412 and C413; diodes CR416 and CR414 do not conduct, the junction of diodes CR413 and CR414 remains at zero and the voltage on capacitor C418 does not change. Therefore, video signals that enter the detector circuit between range gates are not detected.

f. The voltage that is developed across capacitor C418 is negative and decreases the output voltage of emitter follower Q406. The decreased output voltage of emitter follower Q406 decreases the output voltage of emitter follower Q406. The boxcar detector voltage from emitter follower Q407 is developed across resistor R426 and is fed to the audio and age systems through pin A of plug P401 and jack J401 and pin N of jack J601 and plug P601.

Section VIII. AUDIO SYSTEM FUNCTION

2-54. General

a. The audio system receives and amplifies the boxcar detector voltage from the ranging system. A low-pass filter in the audio amplifier circuit smoothes the boxcar detector voltage which is then amplified. The amplified audio signals are then coupled to the headsets through RF filters. These filters block RF energy generated within the radar and thus prevent radiation from the headset leads.

b. The relationship of the audio system with respect to the other functional systems of the radar set is covered in paragraph 2-13.

2-55. System Block Diagram Discussion (fig. 2-30)

a. *Audio Amplifier Circuit.* The audio amplifier circuit consists of low-pass filter R601 and C602, amplifiers Q601 and Q609, push-pull emitter follower Q602 and Q603, audio filter FL3, and a limiting circuit composed of CR601, CR606, R606, R607, and C606. The low-pass filter removes the period-to-period steps of the incoming boxcar detector voltage from the ranging system and provides a smooth output (audio signal) to the amplifier Q601. The audio signal from the low-pass filter is applied through amplifier Q601 and audio filter FL3 to amplifier Q609. The output of audio filter FL3 is also returned to the input of amplifier Q601 through the limiting circuit. This negative feedback prevents overdriving of successive amplifier stages. The amplified output of Q609 is coupled through complementary emitter followers Q602 and Q603 to audio transformer T1.

b. *Audio Transformer and RF Filters.* Audio transformer T1 is a stepdown auto-transformer which couples the audio signal to the headsets. RF filters FL193 and FL104, inserted in series with the output lines, prevent RF radiation from the headset leads, which might cause interference in nearby receiving equipment.

2-56. Audio Amplifier Circuit (fig. 7-11)

a. The boxcar detector voltage from the detector circuit in the ranging system enters the audio system through pin N of jack J601 and plug P601. Capacitor C601 couples this voltage to the low-pass filter consisting of resistor R601 and capacitor C602. The filter attenuates the high frequencies generated by the step changes in the boxcar detector waveform and feeds the resultant signal through coupling resistor R602 to the base of amplifier Q601. The amplified signal from the collector of Q601 is developed across resistor R641 and

is routed through pin P of plug P601 w and jack J601 to audio filter FL3 on the receiver-transmitter center section. This filter attenuates signals above 1,000 Hz and is necessary to remove the 1,300-Hz signal generated by the power converter system. The filtered audio signal is returned through pin R of jack J601 and plug R601, and is coupled through capacitor C606 to the limiting circuit consisting of diodes CR601 and CR606, resistors R606 and R607, and capacitor C606. The filtered audio signal is also routed to the base of amplifier Q609 through capacitor C608.

b. The limiting circuit prevents large audio signals from overdriving amplifier Q609 and complementary emitter followers Q602 and Q603, but allows small signals to be sufficiently amplified. Large audio signals are produced when either the noise generated by the signal IF amplifiers or close range, slow moving targets are gated by the range gate. When the signal from audio filter FL3 exceeds the forward conducting voltage of either diode CR601 or CR606, that diode starts to conduct. During the negative half-cycles of the signal from audio filter FL3, corresponding to the positive half-cycles of the boxcar detector voltage from the ranging system, diode CR606 conducts. Resistors R606 and R607 and capacitor C606 form a low-pass filter which ensures that only the large low frequency signals will appear across resistor R604. The negative half-cycles are added across resistor R604 to the positive half-cycles of the boxcar detector voltage. The input to amplifier Q601 is thereby decreased enough so that overdriving of amplifier Q609 and push-pull emitter follower Q602 and Q603 will not occur.

c. During the positive half-cycles of the signal from audio filter FL3, corresponding to the negative half-cycles of the boxcar detector voltage from the ranging system, diode CR601 conducts. These positive half-cycles are filtered by the low-pass filter, and are added to the negative half-cycles of the boxcar detector voltage across R604, thus decreasing the input to amplifier Q601 and preventing overdriving of amplifier Q609 and complementary emitter followers Q602 and Q603.

d. Amplifier Q601 is forward-biased by current from the voltage divider network consisting

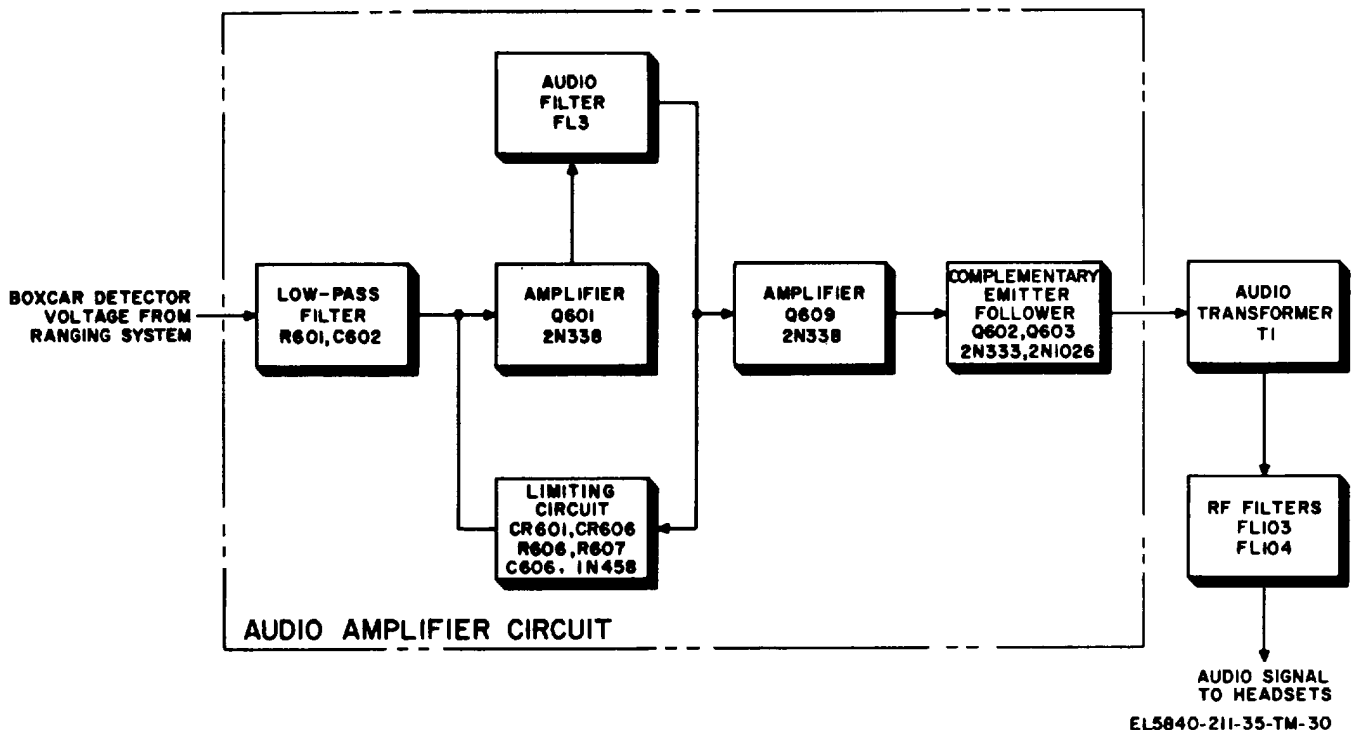

Figure 2-30. Audio system, block diagram

of resistors R603 and R604. Emitter resistor R605 provides degeneration which is necessary in order to maintain a relatively constant and predictable gain and a relatively stable dc operating point.

e. Capacitors C605 and C608 couple the audio signal from audio filter FL3 to the base of amplifier Q609. The de forward bias of divider network consists of resistors R622 and R623. Degeneration is provided by resistor R635.

f. The output signal of amplifier Q609 is developed across resistor R624 and is coupled through capacitor C604 to the base of emitter follower Q602 and to the base of emitter follower Q603. These stages form a complementary symmetry circuit since Q602 is an NPN transistor and Q603 is a PNP transistor. The complementary symmetry circuit is utilized in class B operation; that is, when no signal is present, emitter followers Q602 and Q603 are not conducting and there is no signal flow to audio transformer T1. When the signal from amplifier Q609 is positive, it forward biases emitter follower Q602, causing it to conduct. Emitter follower Q603 remains non-conducting. Signal flow is set up in the series circuit consisting of the +24-volt supply, resistor R608, emitter follower Q602, and audio transformer T1. Due to this action, the positive half-cycles of the signal from amplifier Q609 are passed to audio transformer T1. During the negative half-cycles of

the signal from amplifier Q609, emitter follower Q603 is forward-biased and is caused to conduct; emitter follower Q602 remains non-conducting. Therefore, the negative half-cycles are also passed to audio transformer T1.

g. The audio signal from emitter followers Q602 and Q603 is fed through pin S of plug P601 and jack J601 to terminal 5 of audio transformer T1. Resistor R609 biases audio transformer T1 so that with very low frequency signals (30 to 100 Hz), the transformer core saturates before the audio signal can reach its peak value. Because of this saturation, the audio signal is distorted; that is the wave shape of the audio, signal is clipped before it reaches its peak value. This type of distortion changes the original audio signal to a signal which contains harmonics of the original frequency. This increasing of the frequency makes an otherwise almost inaudible audio signal of a very low frequency (30 to 100 Hz) more audible in the headsets. Resistor R608, which is connected to +24 volts, limits the power dissipated in emitter follower Q602. Resistor R613, which is connected to -20 volts, is the power limiting resistor for emitter follower Q603. h. Resistor R637 and capacitor C611 remove the ripple from the +24-volt supply and prevent interaction of audio system circuits with other circuits in the radar set.

2-57. Audio Transformer and RF Filter

Audio transformer T1 is a stepdown autotransformer in which the secondary winding is not used. The output of the audio amplifier circuit is fed to terminal 5 of the

primary winding. The audio output signal from terminal 2 of audio signal T1 is fed through pin 21' of jack J101 and plug P101 to RF filter FL103. The filter removes any RF signals before feeding the audio signal

Section IX. AUTOMATIC GAIN CONTROL SYSTEM FUNCTION**2-58. General**

a. The automatic gain control (age) system generates a negative dc voltage (age voltage) which controls the gain of the signal IF amplifiers in the receiving system. The age system prevents output signals of the signal IF amplifiers from having an amplitude greater than the amplitude that can be passed by the limiting action of video amplifier Q506 in the receiving system. This limiting action would clip off the peaks of the amplified signals, causing them all to be at practically the same amplitude, and would destroy the amplitude modulation present in the useful output of the signal IF amplifier and detector which is necessary to achieve the desired audio signal for the headsets. Therefore, the age system controls the gain of the receiving system to keep the amplitude of signals at a level that will pass through video amplifier Q506 without being clipped. The age system receives the boxcar detector voltage from the ranging system and develops an age voltage which controls the gain of signal IF amplifiers Q501, Q502, Q503, Q504, and Q505 in the receiving system. The age voltage is also fed to the strobe circuit in the ranging system where it is used to cause a deflection of the needle on the RANGE EXTENSION METERS meter.

b. The relationship of the automatic gain control system with respect to other functional systems in the radar set is covered in paragraph 2-13. The physical location of the component parts of the age system is covered in paragraph 28.

2-59. System Block Diagram Discussion (fig. 2-31)

a. The age system consists of diode CR602, amplifier Q604, filter R619 and C607, and emitter follower Q605.

b. Prior to the boxcar detector voltage from the ranging system entering the age system, the 2-50 through pin J of jacks J102 and J103 to the headsets. The audio output reference (ground potential) is taken from terminal 1 of audio transformer T1 and is routed through pin 46 of jack J101 and plug P101 to RF filter FL104. This filter performs the same function as RF

filter FL103. The filtered audio output reference is fed through pin K of jacks J102 and J103 to the headsets. The following conditions exist: diode CR602 is not conducting, and amplifier Q604 is developing a steady negative dc voltage. This negative dc voltage is being fed as an age voltage through filter R619 and C607 and emitter follower Q605 to the strobe circuit in the ranging system, and to the signal IF amplifiers in the receiving system.

c. When the boxcar detector voltage from the ranging system is applied to diode CR602 as a negative voltage, the diode conducts, and a negative voltage is applied to the base of amplifier Q604. Diode CR602 is normally reverse-biased and will not conduct until the applied voltage is great enough to overcome this bias. The boxcar detector voltage has one step for each repetition rate.

d. The current in amplifier Q604 increases and causes a decrease in the voltage drop across filter R619 and C607. This filter delays the age action to the receiving system. The output across capacitor C607 is fed to the base of emitter follower Q605.

e. This decreased voltage on the base causes a decrease in the negative output of emitter follower Q605. This decreased output is fed as an age voltage to the strobe circuit in the ranging system, and to the signal IF amplifiers in the receiving system.

f. When no targets are being gated, the age voltage (the negative output of emitter follower Q605) is determined by the setting of VOLUME control R105 on the control panel which applies an age voltage level to the base of emitter follower Q605.

2-60. Diode CR602 (fig. 232)

a. Before the boxcar detector voltage is fed to emitter follower Q407 in the ranging system, electron flow from -20 volts causes voltage drops to appear across resistors R426 (ranging

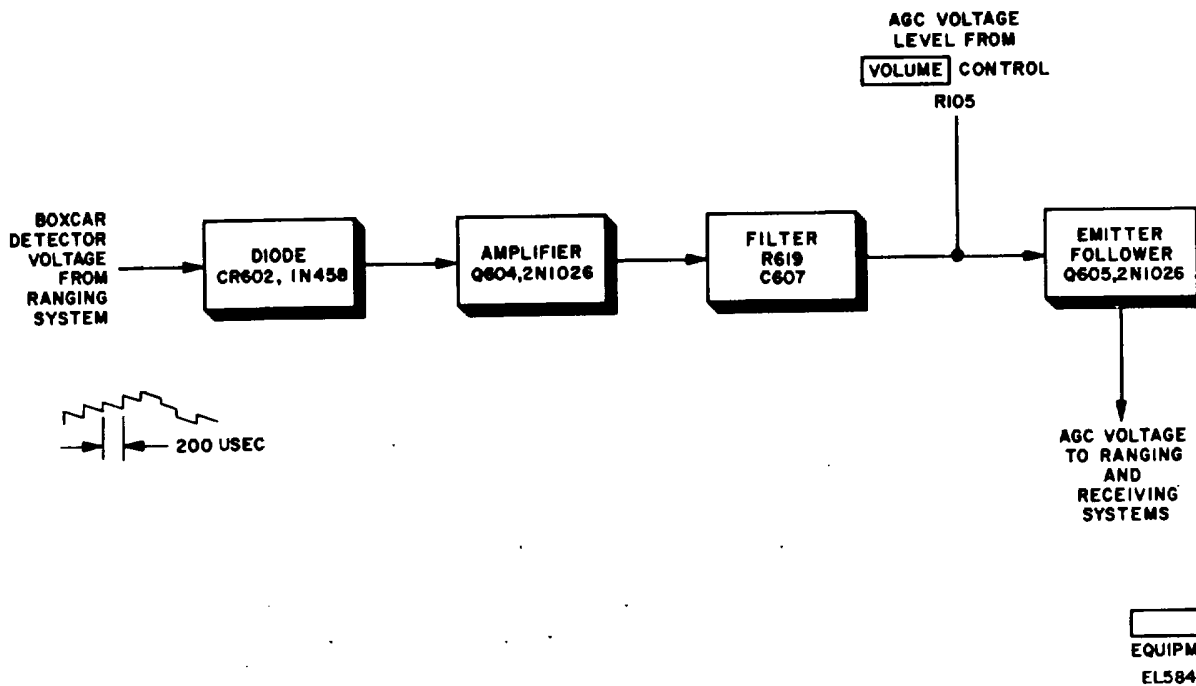

Figure 2-31. Automatic gain control system, block diagram

system), R610, R611, R6, 15, R616, and R612. The voltage drops across resistors R426, R610, and R611 are potentials which, due to their polarity, bias the cathode of diode CR602 positive with respect to the anode. The voltage drops across resistors R616 and R612 bias amplifier Q604 and the anode of diode CR602. Therefore, under these conditions, diode CR602 does not conduct.

b. When the boxcar detector voltage is applied to emitter follower Q407, electron flow through Q407 is decreased and, therefore, the drop across resistor R610 is decreased. When the voltage drop across resistor R610 is decreased, the cathode of diode CR602 becomes negative with respect to the anode, and diode CR602 conducts the negative signal to the base of amplifier Q604.

c. Variable resistor R615, connected between +24 volts and -20 volts, controls the reverse bias voltage level of diode CR602. As the wiper arm of variable resistor R615 is moved toward -20 volts, the voltage drops across resistors R611, R610, and R426 become less. This decrease in voltage across resistors R610 and R426 reduces the reverse bias on the cathode of diode CR602, and, therefore, a less negative boxcar detector voltage is required to cause diode CR602 to conduct.

2-61. Amplifier Q604

Amplifier Q604 is biased to conduction in approximately the center of its operating region by voltages developed

across resistors R616, R612, and R618 (fig. 232). The negative signal from diode CR602 increases the current in biasing resistor R612, thus increasing the forward bias and causing amplifier Q604 to conduct more current. This increased current causes a large voltage drop across resistor R617, and decreases the resultant total voltage drop across amplifier Q604 and resistor R618. Since amplifier Q604 and resistor R618 are connected in parallel with a filter consisting of resistor R619 and capacitor C607, the voltage on capacitor C607 decreases. This decrease is not instantaneous since capacitor C607 discharges slowly to reach the lower voltage. This slow discharge acts as a delay in functioning of the age system to prevent distortion or blocking of the doppler pulses passing through the receiving system. These pulses, of varying amplitude, form the doppler envelope wave form which determines the pitch of the audio signal heard in the headsets.

2-62. Emitter Follower Q605

a. When diode CR602 (fig. 232) is not conducting, the output of emitter follower Q605, a negative dc voltage of approximately 3 volts, is developed across resistor R621. VOLUME CONTROL potentiometer R105 on the control panel, connected in series with resistor R109 and +24 volts, acts as a voltage divider and develops a voltage-to-bias emitter follower Q605 through re-

sistor R620. This voltage adjusts the age voltage level when diode CR602 is not conducting. When potentiometer R105 is adjusted counterclockwise, more positive voltage is obtained from the voltage divider and the forward bias on emitter follower Q605 is decreased.

b. When diode CR602 conducts, the decrease in the voltage across capacitor C607 decreases the forward bias on emitter follower Q605. Therefore, current flow in emitter follower Q605 is decreased and the output developed across resistor R621 decreases.

c. The afc voltage output of emitter follower Q605 is applied to the strobe circuit in the ranging system and to the signal IF amplifiers in the receiving system. When the output of the age system decreases toward ground (becomes more positive), the gain of signal IF amplifiers Q501, Q502, Q503, Q504, and Q505 in the receiving system is decreased. A decrease in the output of emitter follower Q605 also causes a backward deflection of the needle of the RANGE EXTENSION METERS meter.

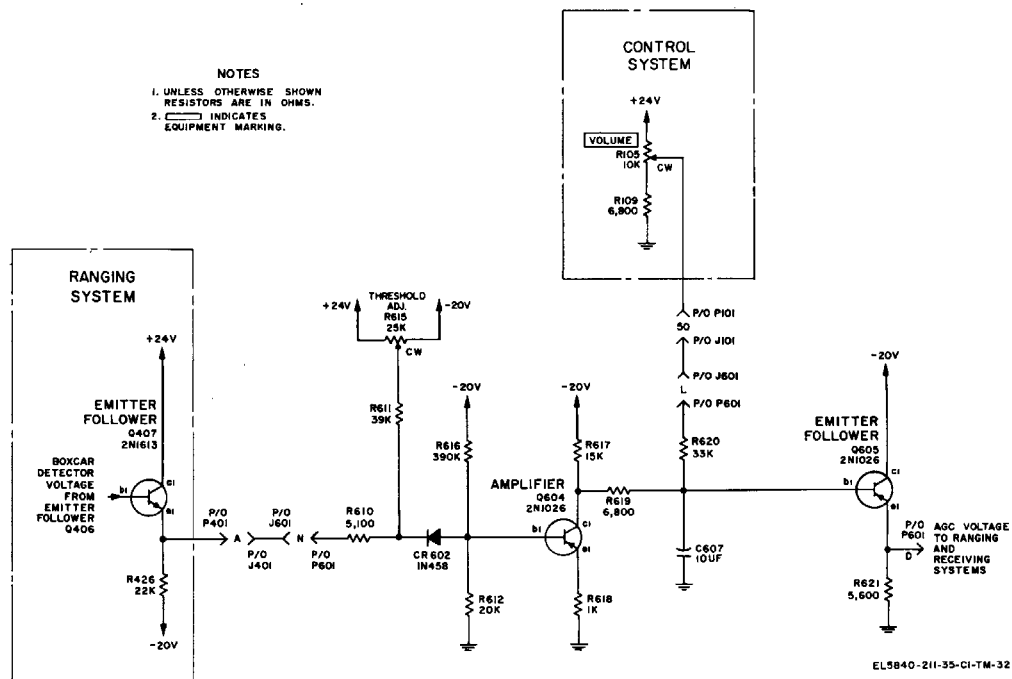

Figure 2-32. Automatic gain control system, simplified schematic design

Section X. POWER CONVERTER SYSTEM FUNCTION

2-63. General

a. The power converter system furnishes ac and dc voltages for the operation of Radar Set AN/PPS-4A. The power converter system operates on a nominal voltage of +24 volts dc from an external power source. The voltage may be as low as +22.5 and as high as +27.5 volts for satisfactory operation of the radar set. The power converter system is not regulated, but the voltages it furnishes can be kept at the proper value by adjustment of VOLTAGE ADJ switch S102 in the control system. The output voltages of the power converter system are +270, +250, -150, +120, +24, and -20 dc and 7, 6.3, and 2.7 volts rms.

b. The relationship of the power converter system with respect to other functional systems of the radar set is described in paragraph 2-13.

- (2) Positive 250 volts to receiving system.
- (3) Negative 150 volts to the afc system.
- (4) Positive 120 , volts the ranging system.
- (5) Positive 24 volts to the ranging, receiving, audio, agc, and afc systems.
- (6) Negative 20 volts to the ranging, receiving, agc, audio, and afc systems.

2-64. System Block Diagram Discussion
(fig. 2-33)

a. *Power Converter System.* The power converter system consists of a flip-flop circuit, rectifiers, and filters.

b. *Flip-Flop Circuit.* The flip-flop circuit, consisting of multivibrators Q801 and Q802, transformers T801 and T802, and switch S102 (control system), receives its energizing dc voltage from an external power source, and produces a square wave output at the secondary winding of transformer T801. Oscillations of approximately 1, 400 Hz are produced due to the characteristics of saturating iron core transformer T802. The primary of transformer T801 provides the load for multivibrators Q801 and Q802. The turns ratio between the primary and secondary of transformer T801 can be adjusted by VOLTAGE ADJ switch S102 which selects the primary taps. This allows the radar to operate over an input voltage of +22.5 to +27.5 volts. Transformer T801 has three windings which produce square waves of 7, 6.3, and 2.7 volts rms to supply the filaments and lamps of the radar. The outputs from the remainder of the secondary taps of transformer T801 are rectified and filtered.

c. *Rectifiers and Filters.* In order to produce dc voltages for the operation of the radar set, the square wave outputs of the multitapped secondary of transformer T801 are rectified and filtered by diodes and capacitors. The outputs of the rectifiers and filters are

- (1) Positive 270 volts to the transmitting system.

2-65. Flip-Flop Circuit

a. Dc input of +22.5 to +27.5 volts is supplied from POWER switch S101 through pin 26 of plug P101 and jack J101 (fig. 7-13) and through pin 14 of jack J801 and plug P801 (fig. 7-12), by means of an external power source having its negative terminal grounded through interlock switch S1 in the center section of the receiver-transmitter. The positive dc voltage is applied to the emitter of multivibrators Q801 and Q802. The collectors of multivibrators Q801 and Q802 are returned to ground through the primary windings of T801. Voltage divider R801 and R802 established the initial starting bias required for the bases of multivibrators Q801 and Q802.

b. Starting oscillation of the circuit depends on the unbalance existing between the apparently identical circuits of multivibrators Q801 and Q802. This is due mainly to transistor unbalance. Because of this unbalance, when the two transistors start to conduct, one will conduct with a slightly higher current.

c. Assume that multivibrator Q801 conducts more than multivibrator Q8(02 at the start of operation. This action would cause electrons to flow from terminal 1 of transformer T801, making terminal 1 positive with respect to terminal 8. Electrons will also flow from terminal 2 to terminal 1 of transformer T802, making terminal 1 positive with respect to terminal 2. The polarity of transformer T802 is such that terminal 3 will then be positive %with respect t3 terminal 5. The negative voltage at terminal 5 will cause multivibrator Q801 to conduct more and the positive voltage at terminal 3 will drive multivibrator Q802 toward cutoff.

d. The flux in the core of transformer T802 increases at a relatively constant rate until saturation of the core is reached. At core saturation, further increase in current does not increase the flux in the core. Since the flux remains comparatively constant, no voltage is induced in windings 3-5. The induced voltages quickly fall to zero,

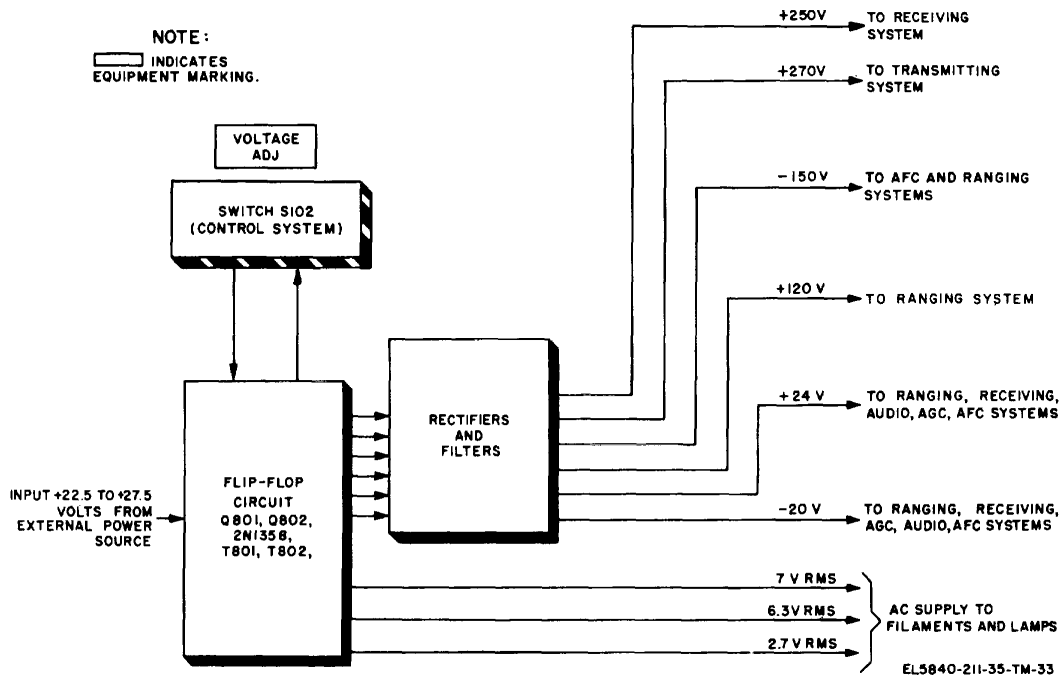

Figure 2-33. Power converter system, block diagram

reducing the base current so that multivibrator Q801 can no longer be held in saturation. This causes the voltage to increase across multivibrator Q801, thus decreasing the current flow through winding 1-2 of transformer T802.

e. As the current flow in winding 1-2 of transformer T802 decreases, the flux in the core decreases and a negative voltage is induced across winding 1-2 of transformer T802. Due to the polarity of the transformer, terminal 3 of the transformer becomes negative and terminal 5 becomes positive. The positive voltage at terminal 5 drives multivibrator Q801 further into cutoff: the negative voltage at terminal 3 drives multivibrator Q802 to conduction. Multivibrator Q801 is maintained at cutoff and multivibrator Q802 conducts heavily until the core of transformer T802 saturates. The saturation which takes place under this condition will be in the opposite direction to the saturation which occurred in *d* above. Once this saturation takes place, the current in winding 1-2 will decrease and the polarity of the induced voltages will reverse, thereby switching multivibrator Q801 from cutoff to conduction and multivibrator Q802 from conduction to cutoff. The cycle continues to repeat itself at a rate of 1, 400 Hz.

f. When multivibrator Q801 starts to conduct and multivibrator Q802 starts to cut off, electron current flow from terminal 8 to terminal 1 of transformer T801 increases and electron current flow from terminal 8 to terminal 15 decreases. Therefore, the flux developed by winding 8-1 and the flux developed by winding 8-15 add to induce square wave voltages across T801. Terminal 16 is positive with respect to terminal 33. When multivibrator Q802 starts to, conduct and multivibrator Q801 starts to cut off, a square wave voltage is induced across the secondary windings of transformer T801. However, on this half of the cycle, terminal 33 is positive with respect to terminal 16. The output square wave , voltage is determined by the turns ratio of the primary and secondary windings of transformer T801. This 510-ohm feedback loop resistors (fig. 7-12) are current limiting resistors of particular importance when transformer T802 is saturated. When this transformer is saturated, it will have almost zero impedance; therefore, the 510-ohm resistors are used to prevent the impedance in the feedback loop from becoming zero and thereby causing damage to the transformers, or blowing fuses.

g. The amount of transformer load in the collector circuit of the transistors is determined by the terminal of transformer T801 which has been selected by VOLTAGE ADJ switch S102 in the control system. The purpose of this switch is to obtain the proper secondary-to-primary turns ratio, so that when the external power source is a battery, the voltage of which has decreased with use, it may still supply the proper voltages for the radar set without the use of a regulated supply.

2-66. Rectifiers and Filters

a. The voltages tapped from the secondary to transformer T801 (fig. 7-12) are ac voltages. For use in the radar set, these ac voltages are changed to dc voltages by means of full-wave rectifier diodes CR801 through CR810 and CR812 and CR813.

b. Diodes CR809 and CR810 form a full-wave rectifier to produce the +270-volt output. Electrons will flow freely from the cathodes of diodes CR809 and CR810 to the anodes when the anodes are positive with respect to the cathodes. Therefore, diode CR809 will conduct when terminal 16 is positive (during the positive half of the square wave); diode CR810 will conduct when terminal 16 is negative (during the negative half of the square wave). This flow of electrons produces a positive dc voltage. Full-wave rectifiers CR803 and CR804, CR805 and CR806, and CR812 and CR813 function in the same manner as full-wave rectifier CR809 and CR810.

c. Diodes CR807 and CR808 form a full-wave rectifier to produce the 150-volt output. Electrons will flow freely from the cathodes of diodes CR807 and CR808 to the anodes when the cathodes are negative with respect to the anodes. Therefore, diode CR807 will conduct when terminal 16 is negative (during the negative half of the square wave); diode CR808 will conduct when terminal 16 is positive (during the positive half of the square wave). This flow of electrons produces a negative dc voltage across the output load. Full-wave rectifier CR801 and CR802 functions in the same manner as full-wave rectifier CR807 and CR808.

d. As discussed in b and c above, energy is supplied from a rectifier in pulses. The fluctuations can be reduced considerably if some energy can be stored in a capacitor while the rectifier is putting out its pulse and allowed to discharge from the capacitor between pulses.

e. Pulses conducted by full-wave rectifier CR803 and CR804 charge capacitor C802 to the peak voltage of rectifier diodes CR803 and CR804 within a few cycles. The charge on capacitor C802 represents a storage of energy. When the output of full-wave rectifier CR803 and CR804 falls, the voltage across capacitor C802 does not fall immediately. Instead, the energy stored in capacitor C802 is discharged through its load during the time that full-wave rectifier CR803 and CR804 is not supplying energy. The voltage across capacitor C802 decreases very slowly due to the large value of the capacitor (60 af). Full-wave rectifier CR803 and CR804 does not begin to pass current until its output voltage exceeds the voltage across capacitor C802. Therefore, the amplitude of the fluctuations is greatly decreased and the output is a relatively steady dc voltage.

f. Capacitors C801, C804, C805, and C806 function as filters in the same manner as capacitor C802. Resistors R803 and R804 divide the voltage across capacitors C805 and C806 so that individual voltage ratings are not exceeded. Resistor R808 is the bleeder resistor for capacitor C804.

g. Capacitor C807 is part of a pi-type filter circuit for the +270-volt line. Capacitor C6 and inductor L1 located in the center section of the receiver-transmitter (fig. 2-34) constitute the rest of the pi-type filter circuit. The function of capacitors C807 and C6 is the same as that of capacitors C807 and C6 is the same as that of capacitor C802. Inductor L1 supplies its stored energy to the load, thus maintaining a constant current source to the load and eliminating ripple. Resistor R807 is the bleeder resistor for capacitor C807.

h. The rectifiers and filters in the power converter system deliver the following outputs:

Output (volts de)	Current (ma)	Maximum ripple peak to peak, under resistive load (volts)
+ 270	26	0.3
+ 120	12	1.5
+ 250	3	0.3
+24	60	0.4
+20	40	0.4
+150	8	0.4

NOTE

In the radar set, the ripple voltages will be equal to, or less than, those shown above.

i. The voltages listed in the chart in h above are used in the following functional systems of the radar set:

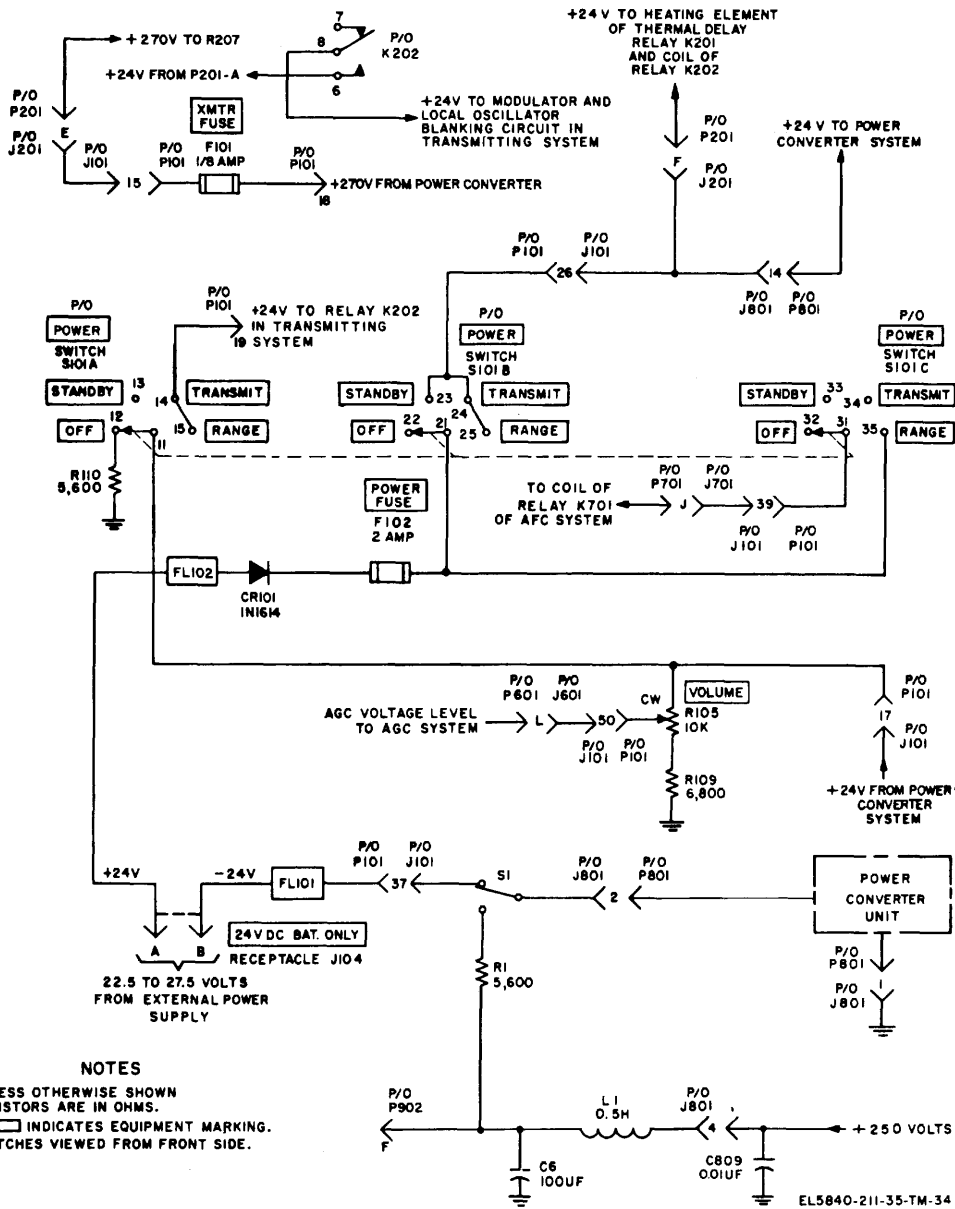

Figure 2-34. Control circuit power distribution, simplified schematic diagram

(1) Positive 270 volts is applied through terminal board TB1, in the center section of the receiver-transmitter, to P101 and J101, through control system fuse F101, through P101 and J101, to the transmitter system through J201 and P101 to R207.

(2) Positive 250 volts is applied through terminal board TB1, in the center section of the receiver-transmitter, to local oscillator V902 of the receiving system.

(3) Negative 150 volts is applied through terminal board TB1, in the center section of the receiver-transmitter, to the strobe unit of the ranging system at resistors R1002 and R1022 and to the afc system at internal test point E601, and to the control system.

(4) Positive 120 volts is applied through terminal board TB1, in the center section of the receiver-transmitter, to the ranging system at resistor R405.

(5) Positive 24 volts is applied through terminal board TB1, in the center section of the receiver-transmitter to the following points:

(a) To the range unit of the ranging system at resistors R410, R415, R417, and R425 and emitter follower Q407.

(b) To the strobe unit of the ranging system at resistors R1012 and R1013 and diode CR1007.

(c) To the IF signal amplifier of the receiving system at resistor R523 and capacitor C548 and resistor R544.

(d) To the audio system at resistors R637 and R608.

(e) To the afc system at resistors R707,

R711, R713, and R716, emitter follower Q703, and inductor L705.

(f) To internal test points E615 and E613 of the agc system.

(g) To the search and control circuit of the afc system at pin 2 of relay K701 in the afc unit.

(6) Negative 20 volts is applied through terminal board TB1, in the center section of the receiver-transmitter, to the following points:

(a) To the range unit of the ranging system at resistors R407, R412, and R426 and internal test point E428.

(b) To the strobe unit of the ranging system at double emitter follower Q1001 and Q1002.

(c) To the IF signal amplifier of the receiving system at resistors (R522, R527, R528, and R529).

(d) To the audio system at resistor R613 and internal test point E603.

(e) To the afc system at internal test point E731.

(f) To the agc system at resistors R616 and R617 and internal test point E616.

j. The three ac secondary windings of transformer T801 (terminals 30-31, 32-33, and 34-35) produce the following voltages:

(1) A voltage of 6.3 volts rms is supplied to the filament of local oscillator V902 of the receiving system.

(2) A square wave 14 volts peak to peak is supplied to the filament of magnetron V901 of the transmitting system.

(3) A voltage of 2.7 volts rms is supplied to the various lamps on the receiver-transmitter control panel, tripod, and telescope.

Section XI. CONTROL SYSTEM FUNCTION

(

2-67. General

a. The control system contains all the switches, controls, indicators, and receptacles which enable the radar operator to control, monitor, and adjust the radar set. Two cartridge-type fuses in the control system protect the radar set from short circuits or overloads.

b. The relationship of the control system with respect to other functional systems in the radar set is covered in paragraph 2-13.

2-68. Power Receptacle, Power Fuse, Power Switch, and Transmitter Fuse

a. The external power source is connected by a power cable to 24 VDC BAT. ONLY receptacle

fig. 2-34) of the receiver-transmitter. The negative output of the external power source passes through low-pass filter FL101, pin 37 of plug P101, jack J101, interlock switch S1, pin 2 of jack J801 and plug P801 of the power converter unit, pin 1 of plug P801, and jack J801, and grounded in the center section of the receiver-transmitter. Low-pass filter FL101 is a sealed unit containing a pi-network of capacitance and inductance to attenuate the ac components generated by the power converter system and prevent them from feeding back out of the power cable to cause radio interference with other electronic equipment in the area. The positive output of the external power source is connected

through low-pass filter FL102, reverse polarity diode CR101, and 2-ampere POWER FUSE F102 to wafer B and C of three-wafer POWER switch S102. Low-pass filter FL102 functions similarly to filter FL101. Fuse F102 prevents damage to the radar set that might result from accidental short circuits or overloads.

b. If the POWER switch is set at STANDBY, TRANSMIT, or RANGE, +24 volts will be applied through wafer B of the POWER switch, through pin 26 of plug P101 and jack J101, through pin 14 of jack J801 and plug P801 to the power converter system, and will energize this system. Positive 24 volts will also be applied through wafer B of the power switch, through pin 26 of plug P101 and jack J101, through pin F of jack J201 and plug P201 to the heating element of thermal delay relay K201 in the transmitting system. Thermal delay relay K201 provides a 90-second delay in operating relay K202. At the same time that the + 24 volts from the external power supply is applied to the heating element of thermal delay relay K201, the same +24 volts is applied to the coil of relay K202 in the transmitter system. The +24 volts from the external power supply will also be applied through wafer C, when the POWER switch is at the RANGE position, through pin 39 of plug p101 and jack J101, through pin C of jack J70F1 and plug P701 to the coil of relay K701 in the afc system. If the POWER switch is set at STANDBY, TRANSMIT, or RANGE +270 volts from the power converter system will be applied through pin '5 of plug P801' and jack J801, through pin 18 of jack J101 and plug P101', through XMTR FUSE F101, through pin 15 of plug P101, and jack J101, through pin E of jack J201' and plug P201 to resistors R207 and R229 in the transmitting system.

c. When the POWER switch is set at TRANSMIT or RANGE, +24 volts from the power converter system will be applied through pin 8 of plug P801 and jack J801, pin 17 of jack J101 and plug P101, shorted pins 14 and 15 of wafer A of the POWER switch, pin 19 of plug P101 and jack J101, pin A of jack J201 and plug P201', and to pin 6 of relay K202 in the transmitting system. When relay K202 becomes operated, +24 volts will then be applied through pins 6 and 8 of relay K202 to the modulator and the local oscillator blanking circuit in the transmitting system.

d. If the POWER switch is set at TRANSMIT and if the 90-second delay has elapsed, the radar will transmit and receive RF energy.

e. If the POWER switch is set at RANGE and if the 90-second delay has elapsed, the radar will transmit normally but the signal IF amplifier stages will not receive the returned RF energy. Twenty-four volts will be applied from the external power supply through wafer C of the POWER switch, through pin 39 of plug P101, and jack J101, through pin J of jack J701 and plug P701, to the coil of relay K701 of the afc system. When relay K701 becomes operated, +24 volts is removed from the signal IF preamplifiers in the receiving system, thus preventing target echoes from passing through the receiving system; rangemarks from the delay line in the afc system are connected to the signal if amplifier stages in the receiving system for range calibration and testing procedures.

f. If the POWER switch is set at STANDBY and if the 90-second delay has elapsed, the radar set will not transmit but will be ready for operation or testing with no time delay when switched to TRANSMIT or RANGE. The tube filaments will be heated and relay K202 will be operated.

2-69. VOLTAGE ADJ Switch and BATTERY TEST Switch

a. VOLTAGE ADJ switch S102 (fig. 7-13) is a two-deck seven-position switch which compensates for long-term voltage variations of the external power source, such as a battery, where voltage output varies with condition of charge and with environmental conditions. This compensation, accomplished by varying the primary-to-secondary turns ratio of transformer T801 in the power converter system, maintains constant operating voltages for the radar set circuits. Position 1' of the VOLTAGE ADJ switch is used for a +27.5-volt input, which is normally provided by a fully charged 24-volt battery. This position of the switch makes use of the entire primary of transformer T801. Switch position 2 utilizes less of the transformer primary, this increasing the ratio of secondary-to-primary turns. This position is for a +26.5 volt battery output. Each numerically higher position of the VOLTAGE ADJ switch utilizes fewer primary turns, thus increasing proportionately the ratio of secondary-to-primary turns. Position 7 corresponds to a +22.5 volt input.

b. BATTERY TEST switch S104 (fig. 2-35), when depressed, permits RANGE EXTENSION METERS meter M101 to indicate the level of the +24-volt line from the power converter system. When the switch is not depressed, meter M101

indicates the summed agc and strobe voltages which pass through pin W of plug P105 and jack J105 or the constant dc voltage which passes through pin V of plug P105 and jack J105 from the strobe circuit (para 2-50). The +24-volt output of the power converter system is applied through pin Y of jack J105 and plug P105, across a battery test circuit consisting of zener diodes CR1006 and CR1007 and voltage divider R1005 and R1006. Diodes CR1007 and CR1006 are 9-volt Zener diodes which maintain a constant voltage drop across themselves once they have had sufficient bias applied to make them conduct in the Zener region (para 2-49). When switch S104 is depressed, the output of the battery test circuit, the difference in potential between the +24-volt output of the power converter system and the 18-volt drop across diodes CR1006 and CR1007, is applied through resistor R1019 and pin X of plug P105 and jack J105 to the positive side of meter M101; the negative side of meter M101 is grounded. The battery test circuit makes meter M101 more sensitive to changes in the power converter system output voltage, since approximately only 6 volts must be measured across resistor R11005 instead of the +24-volt output. Resistor R1019 limits current flow through meter M101, thereby providing meter protection and setting meter M101 for an approximate half-scale deflection when the output voltage of the power converter system is correct.

2-70. STROBE Switch S105 and RANGE EXTENSION METERS Meter M101

a. STROBE switch S105 is a three-pole, three throw wafer switch which can be set at one of three positions: LONG, SHORT, or OFF.

b. When set at LONG, the STROBE switch (pin contacts 3 and 4, fig. 2-26) connects a 10second sweep from the strobe circuit (through pin U of plug P105 and jack J105) through pin 23 of plug P101 and jack J101' to the comparator circuit in the ranging system. This 10-second (or long strobe) sweep moves the range gate at a linear rate through a 500-meter range (beginning at the range indicated on the RANGE METERS indicator) and quickly returns it to the original range to begin strobing again. The STROBE switch also connects the 10-second sweep through pin M of jack J105 and plug P106 to resistor R1014 in the strobe circuit where the agc and the strobe voltages are summed to provide an output to RANGE EXTENSION METERS meter M101. The summed age and strobe voltages pass 2-60 through pin W of plug P105 and jack J105, and cause the needle of

meter M101 to deflect from 0 to 500 meters during a period of 10 seconds, at the end of which the meter needle quickly returns to zero. Thus meter M101 indicates the strobing of the range gate. If a large target enters the range gate as the range gate is strobing, the age voltage decreases and provides a slight deflection to the left of the needle of meter M101.

c. When set at SHORT, the STROBE switch, pin contacts 1 and 4, (fig. 2-27), connects a 5second sweep from the strobe circuit (through pin T of plug P105 and jack J105) through pin 23 of plug P101 and jack J101, to the comparator circuit in the ranging system. This short strobe sweep functions in the same manner as the long strobe sweep except that, since the short strobe sweep has only a 5-second period, it causes the needle of meter M101' to deflect from 0 to 500 meters in 5 seconds and moves the range gate through a 500-meter sector in 5 seconds.

d. When set at OFF, the STROBE switch, pin contacts 2 and 4, (fig. 2-28), connects a constant dc voltage (through pin V of plug P105 and jack J105) through pin 23 of plug P101 and jack J101 (fig. 2-27), to the comparator circuit in the ranging system. This voltage allows the range gate to remain at the range indicated on the RANGE METERS indicator. The STROBE switch also connects the constant dc voltage through pin M of jack J105 and plug P105 to resistor R1014 in the strobe circuit where the age and the constant dc voltages are summed to provide an output to meter M101. This output passes through pin W of plug P105 and jack J105, and causes an approximate midscale deflection of the needle of meter M101. If a large target enters the range gate, the age voltage decreases and causes a deflection to the left of the needle of meter M101.

2-71. RANGE CONTROL Handwheel, 1st MARK and 7th MARK RANGE CALIBRATION Controls

The RANGE CONTROL handwheel and RANGE CALIBRATION controls (fig. 2-36) vary the range voltage input to the ranging system by ordinary voltage divider action.

a. *Range Control Handwheel.* The RANGE CONTROL handwheel varies the position of the wiper arm of 50k potentiometer R103 and registers the position of the range gate on the RANGE METERS indicator (para 2-74). Poten-

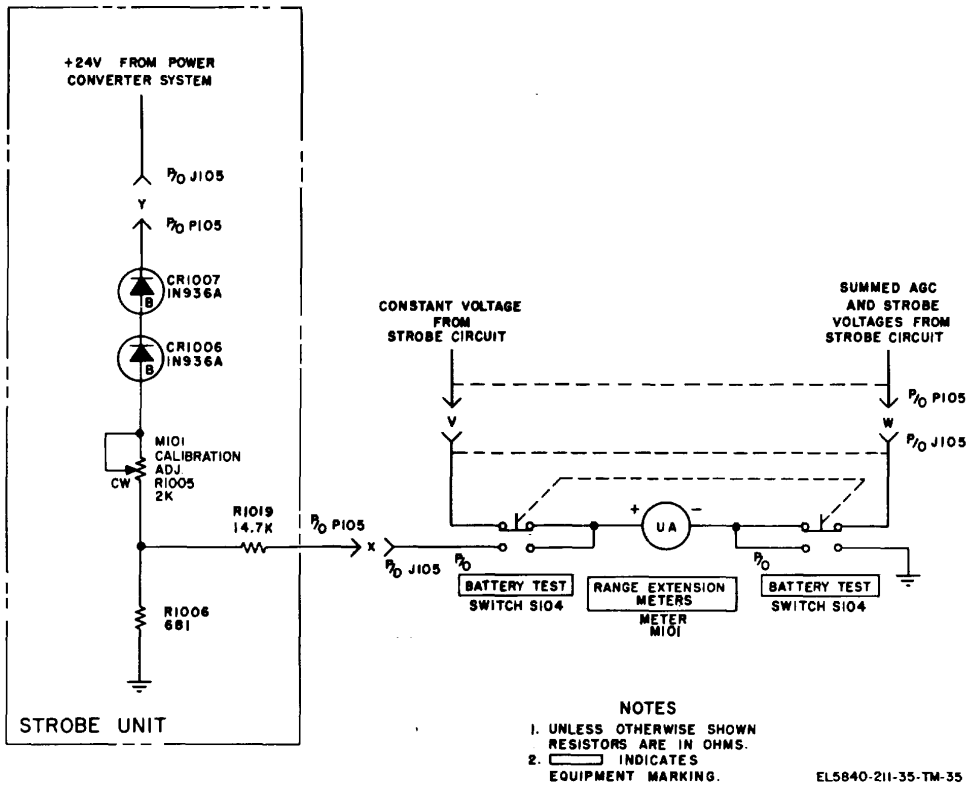

Figure 2-35. BATTERY TEST switch, simplified schematic diagram.

tiometer R103 is part of a voltage divider, consisting of series resistors R1021, R101A, R101B, R102A, and R102B, and parallel resistors R108 and R107. The voltage divider is connected between the +60 volts supplied through pin D of jack J105 by the ranging system, and range ground. The range voltage obtained from the wiper arm of potentiometer R108 is routed through pin 48 of plug P101 and jack J101 to the ranging system where it is used to determine the range of the range gate. The range gate is at minimum range when the wiper arm of potentiometer R103 is closest to ground (RANGE CONTROL handwheel in the completely counterclockwise position); while maximum range is attained when the arm is closest to the +60-volt source (RANGE CONTROL handwheel in the completely clockwise position). Capacitor O1, 0020 in the strobe unit, which is shunted across the series resistors, provides additional filtering for the +60-volt line. Resistors R107 and R108, connected in parallel with potentiometer R108, provides a nonlinear output from the wiper arm of potentiometer R103 to correspond with

the slight nonlinearity of the range sweep. The degree of nonlinearity of the range voltage output is determined by the setting of variable resistor R107.

b. *RANGE CALIBRATION 1st MARK and 7th MARK controls.* The RANGE CALIBRATION 1st MARK and 7th MARK controls are used to calibrate the RANGE METERS indicator with range marks developed by delay line DL701 in the afc system when the POWER switch is set at RANGE. The RANGE CALIBRATION 1st MARK control varies variable resistor R101A and R101B. The RANGE CALIBRATION 7th MARK control varies variable resistors R102A and R102B. Varying these resistors increases or decreases the resistance in voltage divider R1021, R101A, R101B, R102A, R102B, R103, R108, and R107 and thereby varies the output voltage, (range voltages of potentiometer R108. In this manner, the range voltage can be increased or decreased without changing the setting of potentiometer R103.

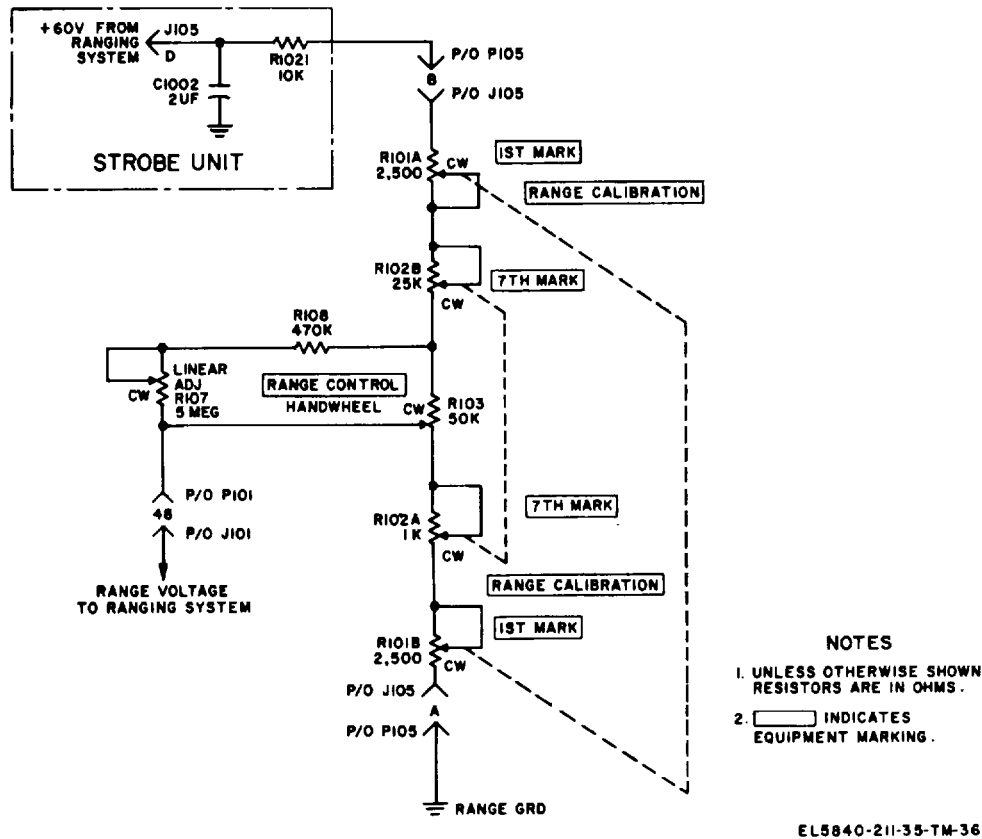

Figure 2-36. RANGE CONTROL handwheel and RANGE CALIBRATION controls, simplified schematic diagram.

2-72. VOLUME Control and HEADSET Receptacles

a. *VOLUME Knob.* The VOLUME knob varies the wiper arm of potentiometer R100 (fig. 7-13) which forms voltage divider with resistor R1019. This voltage divider varies the output of the gain system, which controls the gain of the signal IF amplifiers in the receiving system

b. *HEADSET Receptacles.* Two HEADSET receptacles (fig. 237), mounted on the radar control panel, are connected in parallel across audio output autotransformer T1. The audio signal from T1 is passed through low-pass filter. FL103 and FL104 before being applied to pin, J and K of HEADSET receptacles J102 and J103 Low-pass filters FL103 and FL104 are sealed by pass units containing pi-networks of capacitance and inductance to attenuate high frequency audio signal components.

2-73. Lamp Switches

The control panel of the radar set has three controls that adjust the illumination of the telescope, dials, and indicators of the radar: The TELESCOPE LIGHT switch, the TRIPOD LIGHTS switch, and the PANEL RIGHTS switch.

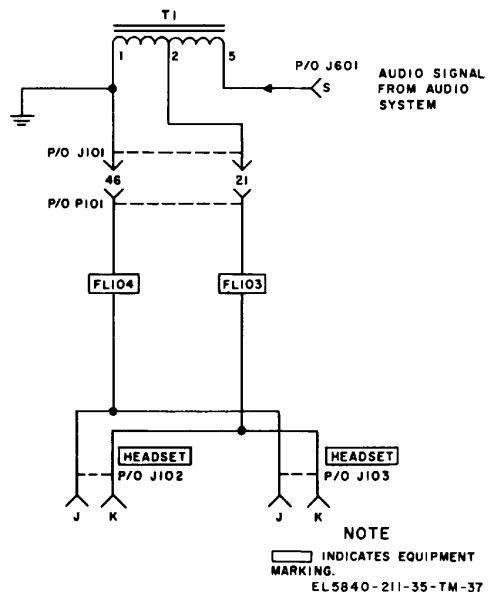

Figure 2-37. HEADSET receptacles, simplified schematic diagram.

a. *TELESCOPE LIGHT Switch.* TELESCOPE LIGHT switch S103 (fig. 7-13) is a simple pushbutton switch which, when depressed, connects the 2.7-volt rms output of the power converter system to the telescope lamp. The 2.7-volt rms output passes through pin 10 of jack J101 and plug P101, through switch S103, through pin 11 of plug P101 and jack J101, and through filter FL1 to the telescope lamp. This lamp is used to illuminate the reticule pattern of the telescope. RF filter FL1 prevents any RF interference with other electronic equipment in the area

b. *TRIPOD LIGHTS Switch.* The TRIPOD LIGHTS switch is used to switch the tripod lamp on and off as well as to vary the intensity of the lamp. The control is attached to the shaft of variable resistor R106 and integral on-off switch S106. Variable resistor R106 is in series with the 2.7-volt rms supply and the tripod lamps so that adjustment of the variable resistor varies the voltage across the lamps. The full counterclockwise position opens switch S106; clockwise rotation from this position closes switch S106 and removes resistance from the circuit to provide increasing illumination from the lamps. The output from switch S106 passes through pin 36 of plug P101 and jack J101, and through RF filter FL2 which prevents any radio interference with other electronic equipment in the area.

c. *PANEL LIGHTS Switch.* The PANEL LIGHTS switch is used to switch the panel lamps on and off as well as to vary the intensity of the lamps. The PANEL LIGHTS switch is attached to the shaft of variable resistor R104 and integral on-off switch S107. Variable resistor R104 is in TM 115840-211-35 series with the

2.7-volt rms supply and the panel lamps, so that adjustment of the variable resistor varies the voltage across the lamps. The five panel lamps (DS101, DS102, DS103, DS104, and DA105) are connected in parallel. The full counterclockwise position opens switch S107; clockwise rotation from this position closes switch S107 and removes resistance from the circuit to provide increasing illumination from the lamps.

2-74. RANGE METERS Indicator

a. The RANGE METERS indicator (fig. 2 38) displays the range of the range gate in meters when the radar is operating in the normal mode. If the radar is operating in either the long or the short strobe modes, the indicator displays the starting point of the range gate strobe. The actual position of the range gate in this case is equal to the indication on the RANGE METERS indicator plus the indication on the RANGE EXTENSION METERS meter.

b. The RANGE METERS indicator is a four digit indicator which is mechanically connected to the shaft of the RANGE CONTROL handwheel through 4-to-1 ratio bevel gears. In addition to the RANGE METERS indicator, the RANGE CONTROL handwheel shaft is also connected to the wiper arm of potentiometer R103 (para 271') through 1-to-2 antiback lash gearing. When the RANGE CONTROL handwheel is rotated through 20 complete turns, the wiper arm of 10turn potentiometer R103 travels from one extreme to the other, and the RANGE METERS indicator varies from 0 to 8, 000 meters.

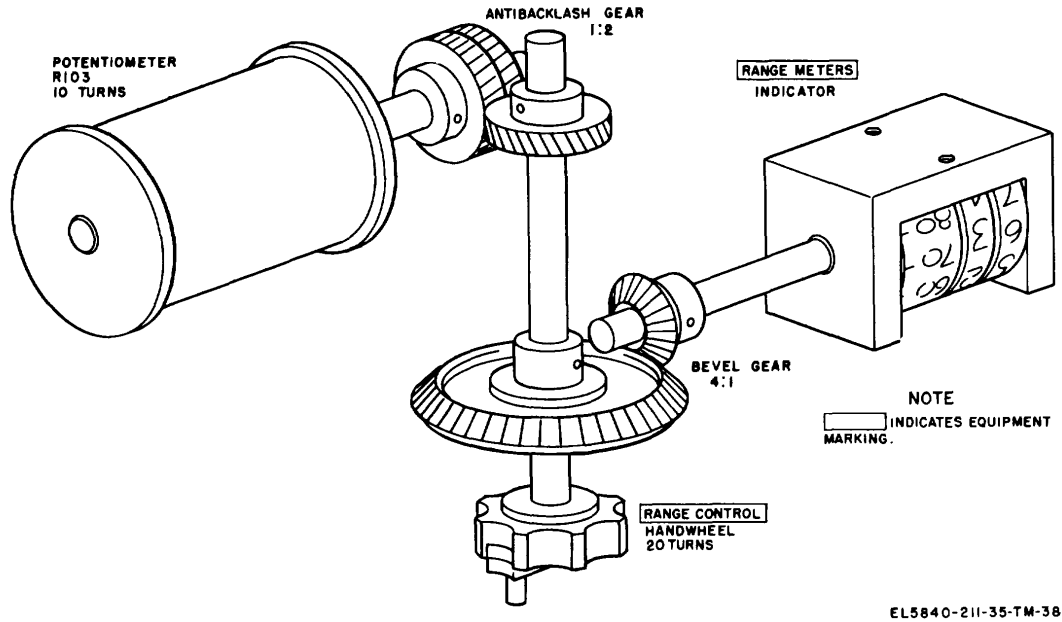

Figure 2-38. RANGE METERS indicator, mechanical diagram.

CHAPTER 3

DIRECT SUPPORT MAINTENANCE

Section I. GENERAL

3-1. Scope of Maintenance

The maintenance duties assigned to the direct support repairman of Radar Set AN/PPS-4A are listed below together with references to the paragraphs covering the specific maintenance functions.

a. Localization of trouble to

- (1) Control Panel (para 3-16)
 - (2) Strobe Unit (para 3-21)
 - (3) Automatic Frequency Control Unit C311'5/PPS-4 (para 3-23).
 - (4) Audio Unit MX-2925/PPS-4 (para 322).
 - (5) Amplifier, Intermediate Frequency AM-41s75/PPS-4A (para 3-19).
 - (6) Power Converter CV-1803/PPS-4A (para 3-24).
 - (7) Range Unit MX-2924/PPS-4 (para 321).
 - (8) Transmitter, Radar T-967/PPS-4A (para 3-17).
 - (9) Microwave unit (para 3-18)
- b. Adjustment and alignment of---*
- (1) Radar Set, AN/PPS-4A (TM 11-5840 21, 1-12).
 - (2) Receiver-Transmitter, Radar RT-752/PPS-4 (paras 3-26 through 3-52).
 - (3) Center Section (paras 3-30 through 352).
 - (4) Strobe unit (para 3-45) (5) Automatic Frequency Control Unit C3115/PPS-4 (paras 340 and 3-41).
 - (6) Audio Unit MX-2925/PPS-4 (para 351).
 - (7) Amplifier, Intermediate Frequency AM-4175/PPS-4A (para 834).
 - (8) Power Converter CV-1803/PPS-4A (para 3-47).
 - (9) Range Unit MX-2924/PPS-4 (para 342).
 - (10) Transmitter, Radar T-967/PPS-4A (para 3-30).

(11) Microwave unit (paras 333 and 3-41)

c. Repair of -

- (1) Case, Receiver-Transmitter CY-2733/PPS-4 (paras 356).
- (2) Radar Set AN/PPS-4A (par 3-53)
- (3) Cable Assembly, Special Purpose CX4934/U (para 354).
- (4) Cable Assembly, Special Purpose CX4935/U (para 3-54).
- (5) Headset, Electrical H-183/PPS-4 (para 85).
- (6) Receiver-Transmitter, Radar RT-752/PPS-4 (paras 3-53).
- (7) Strobe unit (para 3-57)
- (8) Microwave unit (para 3-8)

d. Removal and replacement of--

- (1) Center section (paras 3-60 through 369).
- (2) Strobe unit (para 3-60)
- (3) Automatic Frequency Control Unit C31'1'5/PPS-4 (para 365).
- (4) Audio Unit MX-2925/PPS-4 (para 364).
- (5) Amplifier, Intermediate Frequency AM-4175/PPS-4A (para 3-63).
- (6) Power Converter CV-1803/PPS-4A (para 3-66).
- (7) Range Unit MX-2924/PPS-4 (para 362)
- (8) Transmitter, Radar T-967/PPS4A (para 3-61).
- (9) Microwave unit (para 3-67)
- (10) Radome (para 359)
- (11) Control panel (para -59)
- (12) Indicator, azimuth (para 3-70)
- (13) Tripod leg assembly (para 3-71,)

3-2. Tools, Test Equipment, and Materials Required

Refer to the basic issue items list (BIIL) and the maintenance allocation chart (MAC) in TM 11-840-211-12.

Section II. DS TROUBLESHOOTING1

WARNING

When servicing Radar Set AN/PPS-4A, be extremely careful of the high voltages supplied to the receiver-transmitter. Always set the POWER switch S101 to the OFF position when working inside the receiver-transmitter.

3-3. General Troubleshooting Procedures

The direct support troubleshooting procedures in this section supplement the procedures described in TM 11-5840-211-12. The systematic troubleshooting procedures that can be performed at organizational maintenance category are carried to a higher maintenance category in this section. Troubleshooting procedures begin with operational and sectionalization checks. Localizing techniques used in the direct support troubleshooting procedures are more advanced. The following information will aid in performing procedures necessary to determine the faulty operation.

a. General. The first step in troubleshooting a defective Radar Set AN/PPS-4A is sectionalization of the fault. Sectionalization means tracing the fault to the battery, the tripod, the headsets, or to the receiver-transmitter. Sectionalization is usually accomplished at the organizational maintenance echelon as outlined in TM 11-5840-21112. The second step is to localize the fault. Localization means tracing the fault to a removable and replaceable unit or part as outlined in this section. When the trouble has been localized, the defective unit is removed and referred to higher category of maintenance for repair. A known good unit is substituted for the defective unit.

b. Troubleshooting Aids. The following aids are designed to reduce work and aid in localizing the trouble:

(1) *Visual inspection.* The purpose of the visual inspection is to locate faults without testing or measuring circuits. All visual signs should be observed and an attempt made to localize the fault to a particular unit of the radar set.

(2) *Performance tests.* Performance tests frequently indicate the general location of trouble. In many cases the tests will help in determining the exact nature of the fault. Performance tests are given in TM 11-5840-211-12.

(3) *Block diagrams.* The individual system block diagrams (ch. 2), the functional block diagram (fig. 7-4), and the complete block diagram (fig. 7-5) give the electrical and mechanical relationship among the systems, components, and stages of the radar set. By observing symptoms and reasoning possible causes, it is possible to trace the trouble to a particular block.

(4) *Schematic diagrams.* The schematic diagrams are useful in tracing troubles between components or to individual stages within a component.

(5) *Location of parts illustrations.* The location of parts illustrations show location of units authorized to be removed and replaced by the direct support repairman.

3-4. Voltage Measurements

a. Purpose. Voltage measurements are an aid in determining circuit conditions and in evaluating clues in the course of troubleshooting. Carefully read the notes on the voltage charts and exactly duplicate the conditions under which the normal readings were obtained.

b. Equipment and Conditions. The component voltages and test point voltages listed below were made with a 20, 000-ohm-per-volt meter. All voltage measurements were made with respect to ground unless otherwise stated. In making voltage measurements, insulate the entire test probe except for the extreme tip with tape or sleeving. A momentary short circuit can ruin a transistor.

NOTE

The normal variations of transistor characteristics may cause the emitter, base, and collector voltage readings to vary considerably between radar sets. If the voltage measurements obtained fall within the values listed below, it may be assumed that the circuit is operating properly.

c. Precautions. Observe the following precautions when measuring voltages greater than 500 volts:

- (1) Shut off the power.
- (2) Discharge the high voltage capacitors.
- (3) Connect the multimeter leads to the test points.
- (4) Step away from the multimeter.
- (5) Turn on the power.
- (6) Note the reading on the multimeter.

- (7) Turn off the power
- (8) Discharge the high voltage capacities.
- (9) Remove the multimeter leads.

d. *Transmitter Unit.* Voltage measurements in the transmitter unit are made at relays K201, K202, and at pulse Z201.

Component	Test point	Voltage to ground	Remarks
K201	Pin 3	+23 to +28	Power switch at TRANSMIT
K202	Pin 6	22.8 to 25.2	
K202	Pin 8	22.8 to 25.2	V901 filament voltage measured between pins.
Z201	Pins 8 and 9	6.7 rms to 7.3 rms	

e. *Range Unit.*

Transistor	Voltage to ground			Remarks
	Emitter	Collector	Base	
Q401	-3 to -7	-0.8 to -1.6	-2.5 to -6.5	POWER switch at STANDBY
Q402	-0.8 to -1.8	55 to 60	-0.4 to -0.8	
Q403	-4.75 to -5.25	-0.8 to -1.8	-4.25 to -5.25	POWER switch at TRANSMIT
Q404	0	22 to 25	0.4 to 0.8	
Q405	0	23.8 to 25.2	0	
Q406	0.4 to 1	2.15 to 2.65*	0.8 to 2*	
Q407	-1 to -3	22.8 to 25.2*	0.4 to 1*	

*Measure with respect to jack J405.

f. *IF Amplifier Unit.*

Transistor	Voltage to ground				Remarks
	Emitter	Collector	Base 1	Base 2	
Q501	-0.4 to -1	18.8 to 21.2	0	-0.3 to -0.8	POWER switch at TRANSMIT.
Q502	-0.4 to -1	18.8 to 21.2	0	-0.3 to -0.8	
Q503	-0.4 to -1	18.8 to 21.2	0	-0.3 to -0.8	Adjust VOLUME control for age voltage of -3 volts.
Q504	-0.4 to -1	18.8 to 21.2	0	-0.3 to -0.8	
Q506*	-0.4 to -1	18.8 to 21.2	0	-0.3 to -0.8	
Q505	-0.8 to -1.9	1.5 to 3.5	-0.7 to -1.2	-0.7 to -2.0	
Q507*	17 to 20	10.5 to 19.5	1.5 to 3.5		
Q508	5.7 to 6.1	0	5.1 to 5.9		

*Connect a 1,000- μ f capacitor between the negative side of capacitor C626 (fig. 8-16) and ground when taking voltage measurements at transistors Q506 and Q507.

g. *Audio Unit.*

Transistor	Voltage to ground			Remarks
	Emitter	Collector	Base	
Q601	0.3 to 0.8	8 to 17	0.9 to 1.6	POWER switch at TRANSMIT
Q602	0 to \pm 1	15 to 25.2	0 to \pm 1	
Q603	0 to \pm 1	-12 to -20	0 to \pm 1	
Q604	-0.2 to -1.3	-1.5 to -11	-0.7 to -2	
Q605	0 to -6	-19 to -21	1 to -5.5	
Q606	2 to 5*	-80 to -160	2.5 to 6*	
Q607	0.5 to 3*	2 to 22*	1.5 to 3.5*	
Q609	0.3 to 0.8	8 to 17	0.9 to 1.6	

*Measure with respect to -150-volt supply.

h. *Afc Unit.*

Transistor	Voltage to ground				Remarks
	Emitter	Collector	Base 1	Base 2	
Q701	-0.4 to -1	22.8 to 25.2	0	-0.3 to -0.8	POWER switch at STANDBY.
Q702	-0.4 to -1	22.8 to 25.2	0	-0.3 to -0.8	
Q703	11 to 21	22.8 to 25.2	10 to 20		
Q704	4 to 9.5	12 to 18	5 to 10		
Q705	0	22.8 to 25.2	0		

i. Power Converter Unit.

TB1 (terminals)	Voltage to ground	Remarks
1	22.8 to 25.2	Pin 4 voltage adjusted by external power source. Ground potential Measure with respect to pin 12 Measure with respect to pin 14 Dependent on external power source
2	-3	
3	237 to 262	
4	269 to 271	
5	114 to 126	
6	22.8 to 25.2	
7	0	
8	0	
9	-19 to -21	
10	-140 to -158	
11	12 to 13.2 peak to peak	
12		
13	13 to 14.5 peak to peak	
14		
15	19 to 27.5	

j. Strobe Unit.

Transistor	Voltage to ground			Remarks
	Emitter	Collector	Base	
Q1001	0.4 to 0.8 with respect to base Q1001.	-19 to -20	0 to -16 maximum sweep. -5 to -11 sweep.	POWER switch at STANDBY
Q1002	0.4 to 0.8 with respect to base of Q1002.	-19 to -20	0.4 to 0.8 with respect to base of Q1001.	STROBE switch at LONG

3-5. Waveform Analysis

a. Waveforms may be observed at various test jacks and at other significant points in the circuits of the radar set by using Oscilloscope AN/USM-281 or equivalent. Detailed instructions for operating the oscilloscope are included with the test equipment. The normal waveforms that should be obtained at test jacks and at other significant points are shown on waveform illustrations located in each system maintenance paragraph. By comparing observed waveforms with the normal waveforms, trouble can sometimes be quickly located.

b. Before comparing the waveforms with the normal waveforms, carefully read the notes on the waveform illustrations and exactly duplicate the conditions under which the normal waveforms were obtained. If an observed waveform does not resemble the normal waveform, trouble is indicated.

c. A departure from the normal waveform indicates trouble between the point at which the waveform is

observed to be normal and the point at which the waveform is observed to be abnormal. For *example*, if a waveform is observed to be normal at the grid/base of a stage, and abnormal at the plate/collector of the same stage, it is an indication that the trouble is in that stage.

d. When a waveform at a certain point is observed to be abnormal, the cause may be the absence of signal from another unit. The point at which to start checking waveforms is at the unit input jack.

3-6. Replacing Parts

Careless replacement of parts often creates new troubles. When replacing parts, observe the following precautions:

a. Before a part is unsoldered, note the positions of the leads. If a part, such as a transformer or a switch, has a number of connections, tag each of the leads in order to make the proper connections when replacing the part. Be careful not to damage other leads by pulling or pushing them away

b. Make well-soldered joints. A carelessly soldered joint may create a new trouble and is one of the most difficult troubles to locate. Be careful not to allow drops of solder to fall into the equipment; they may cause short circuits.

c. When replacing a part in the RF or IF circuits, place it in exactly the same position as the original part. A part that has the same electrical value but different physical size may cause trouble in high frequency circuits. In such circuits, use the same type capacitor for replacement and the same length lead because of the self-resonant frequencies of different brands of capacitors. When replacing parts in high frequency circuits, give particular attention to proper grounding; use the same ground as in the original wiring. Failure to observe these precautions when replacing parts in high frequency circuits may result in decreased gain or possibly in unwanted oscillations.

d. Whenever a part has been replaced, make any necessary adjustments and check the performance of the equipment to be sure that the original trouble has been remedied and that no new trouble has developed in the equipment as a result of the repair.

3-7. Interlock Switch 51 (fig. 3-1)

The radar set has one interlock switch that opens when the radome is pulled approximately 1 inch from the receiver-transmitter center section. When open, the interlock switch disconnects the +24-volt external power source input from the power converter systems and transmitting system and also discharges capacitor C6 (fig. 3-1) in the power converter system.

WARNING

The primary function of the interlock switch is to protect personnel against injury from voltages greater than 500 volts.

To disable the interlock switch, pull the interlock switch full forward. When the interlock switch is disabled, observe the following precautions:

a. Avoid personal contact with all parts of the radar set as carefully as if you were servicing a piece of rotating machinery with the safety guards removed.

b. Do not permit any part of your body to make direct contact with the radar set ground potential.

c. Make a habit of keeping both hands in your pockets or behind your back when making observations of energized circuits.

3-8. Fuses

Radar Set AN/PPS-4A contains a POWER fuse and a XMTR fuse. The fuses protect vital circuits within the radar set. Fuse replacement procedures are given in TM 11-5840-211-12.

3-9. Testing and Replacing Tubes, Transistors, and Diodes

a. *Tube Testing and Replacement.* The tubes in Radar Set AN/PPS-4A are the magnetron (V901-) in the transmitting system and the klystron (V902) in the receiving system. These tubes should be tested by observing their performance in the circuits. If a tube is suspected of being defective, it should be replaced.

b. *Testing and Replacing Transistors and Diodes.* Transistors are tested and replaced at higher category, of maintenance. Diodes however are checked for forward and backward resistance. Place the multimeter leads across the diode, then reverse the leads across the diode. A low resistance reading should be obtained in one direction and a 'high resistance reading should be observed in the reverse direction. Testing of the four-layer diodes is described in paragraph 3-10.

3-10. Testing Four-Layer Diodes

- a. Connect the test apparatus as shown in A, figure 3-2. Make sure that the variable autotransformer is turned to the minimum voltage position. Set the oscilloscope at external sweep.
- b. Apply 115-volt, 50-Hz power to the variable autotransformer.
- c. Turn the variable autotransformer to increase the voltage until a vertical trace twice nominal V_s of the diode is obtained on the oscilloscope.

NOTE

The oscilloscope trace may be slightly elliptical because of the unbalance of capacitance and resistance.

d. Eliminate effects of unbalance by depressing switch S1, and adjusting variable resistor R_i' and variable capacitor C1 to obtain a single vertical line. Release switch S1 and remove the input power by turning the variable autotransformer to the minimum voltage

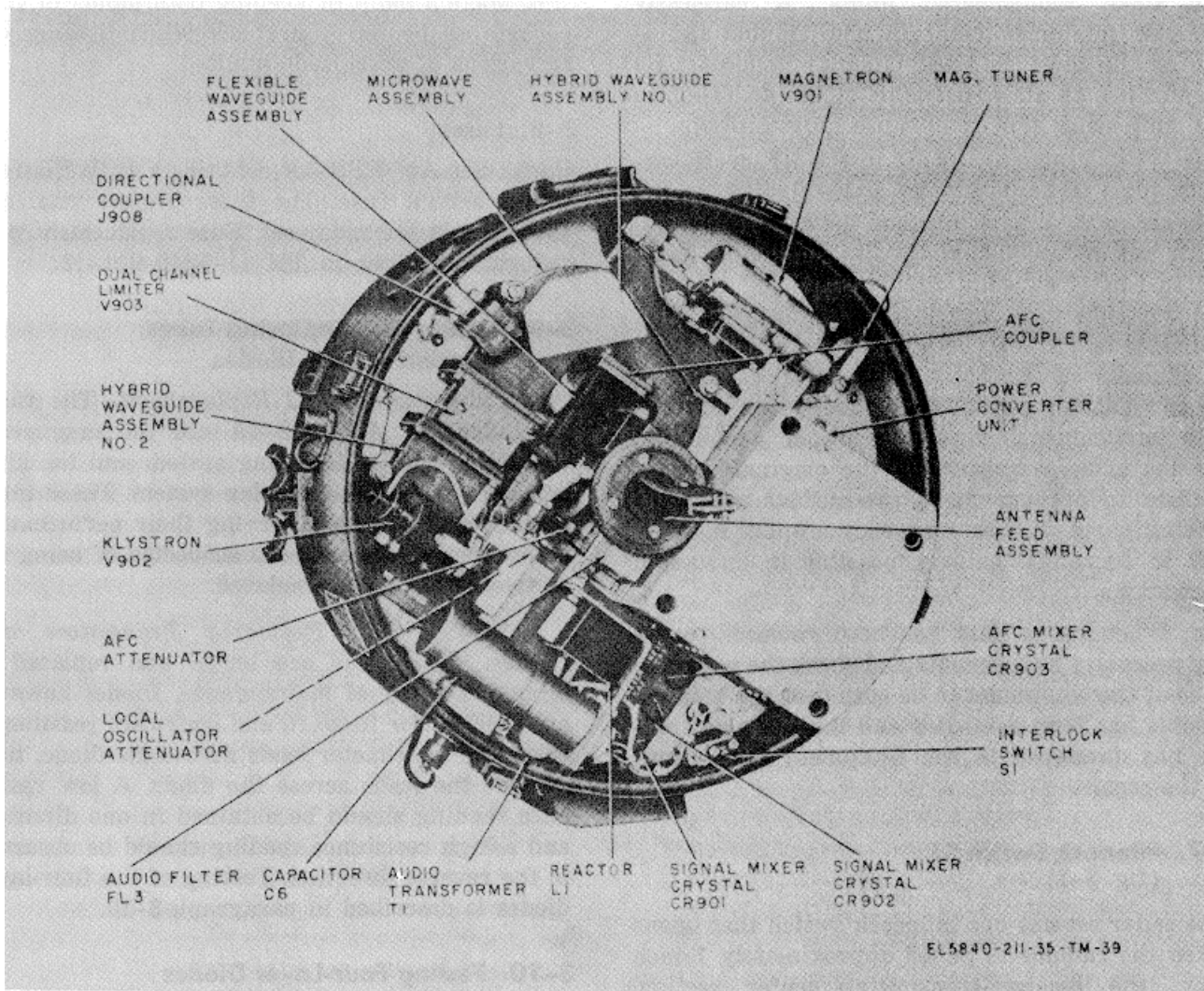

Figure 3-1. Receiver-transmitter, center section, front side.

e. Depress switch S1 and adjust the variable autotransformer such that the equivalent vertical deflection is 1 1/2 times nominal VS of the four layer diode under test. Release switch S1.

f. Calibrate the full horizontal deflection of the oscilloscope for 50 volts.

g. Insert the four-layer diode to be tested, and depress switch S1. The oscilloscope display should be similar to that shown in B, figure 3-2.

h. Determine breakdown voltage VS and holding current I_h from the oscilloscope display, indicated by the vertical and horizontal traces: horizontal deflection (volts)

$$I_h \text{ (ma)} = \frac{\text{horizontal deflection (volts)}}{1,000}$$

i. Release switch S1 and remove the input voltage by turning the variable autotransformer to the minimum voltage position.

3-11. Check and Repair of Power Cable, Headsets, Telescope Light Cable, and Telescope

a. *Continuity.* When measuring for continuity, the ohmmeter leads sometimes are not long enough to be connected to the end of the cable. The following procedure is given as a convenient method of determining the condition of a cable:

- (1) Place a resistor of known value (50, 000 ohms or more) from one end of the cable to ground.
- (2) Connect the ohmmeter leads between the cable and ground at the other end of the cable.
- (3) If the meter indicates approximately 50, 000 ohms, the cable has continuity.
- (4) If the meter indicates infinite resistance, the cable is open.

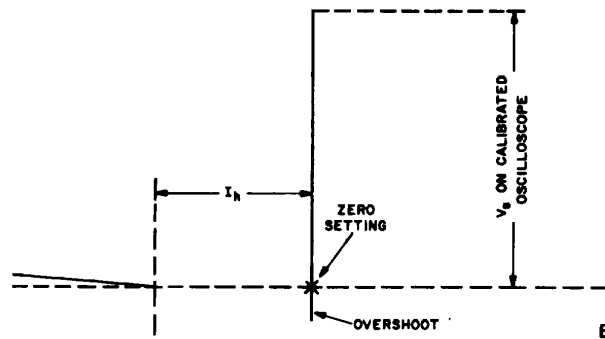
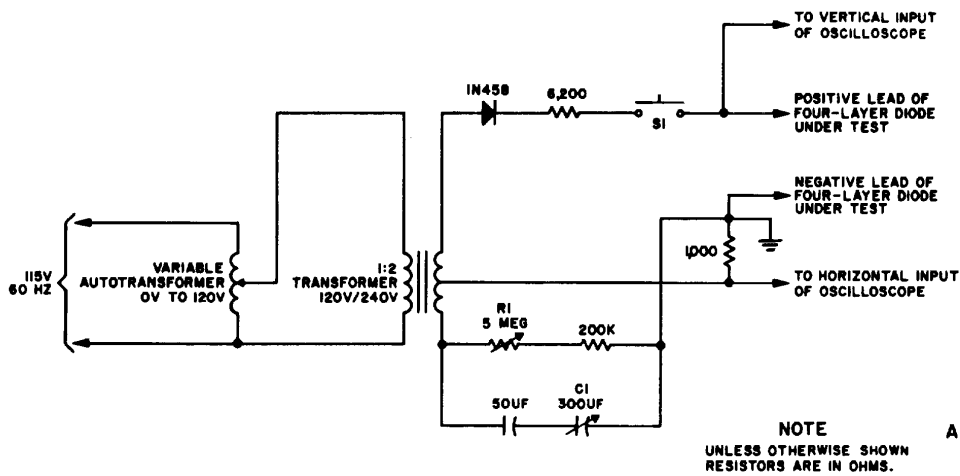

EL5840-211-35-TM-40

Figure 3-2. Four-layer diode tester.

(5) If the meter indicates zero resistance, the cable is shorted to ground.

(6) If the meter indicates much less than, 50,000 ohms, but not necessarily zero, the cable has a dc leakage path to ground.

b. Power Cable.

(1) Using Multimeter TS-352B/U, check the continuity of the power cable between pin A on one connector and pin A on the connector at the other end of the cable. Repeat the procedure for pin B.

(2) Damaged connectors may be unscrewed, pulled back, and disconnected from the cable with a soldering iron. The two connectors are not molded but have watertight glands.

(3) If the cable is damaged, replace it with a new cable.

c. Headset. Using Multimeter TS-352B/U, check for continuity between pin J and pin K on plug P102 or plug P103. (The other eight pins are open.) If there is no continuity, the headset is defective. Defective headsets should be replaced.

d. Telescope Light Cable.

(1) Place POWER switch S101 in the STANDBY position.

(2) Depress the TELESCOPE LIGHT button; if the telescope lamp does not light, replace with a new lamp. (Refer to the replacement procedure for the telescope lamp in TM 116-840211-12.)

(3) Depress the TELESCOPE LIGHT button if the lamp still does not light; check the 2.7volt rms output of the power converter unit (para

3-24). If a 2.7-volt rms level is present, the telescope light cable has a break, or one of its connectors is damaged.

(4) Damaged connectors may be unscrewed, pulled back, and disconnected from the cable with a soldering iron. The two connectors are not molded but have watertight glands.

(5) If the cable is damaged, replace it with a new cable.

e. *Telescope.* Refer defective telescopes to ordnance maintenance for repair.

3-12. Parts Substitution

a. Do not substitute parts indiscriminately. Substitute only when the following conditions are satisfied:

- (1) The trouble has been isolated to a specific stage.
- (2) The tube or transistor has been replaced.

b. When an open capacitor is suspected, connect a known good capacitor of equal value across the capacitor and check the operation of the component.

c. When all other possibilities of trouble are ruled out, substitute a good part for the one which is suspected of being defective.

3-13. Intermittents

a. If the operation of a component is intermittently faulty, the trouble may be impossible to locate when the component is functioning normally. Such trouble can often be found by connecting an oscilloscope to appropriate test points and lightly tapping each part in the suspected stage or portion of the component with a nonmetallic pencil or insulated rod and, at the same time, watching the oscilloscope. Lightly tap all the parts, tubes, transistors, and wiring. If the oscilloscope presentation remains normal, repeat the tapping process at adjoining stages.

b. Intermittent operation can be caused by loose connections, broken wires, or parts (including tubes and transistors) with internal defects. Sometimes intermittent trouble can be located by observing erratic behavior of one of the controls.

3-14. Special Test Equipment Required but not Supplied With Radar Set AN/PPS4A

The following chart lists the special test equipment that is not supplied with Radar Set AN/ PPS-4A, but is required to maintain the radar set. The chart also lists a reference that covers each item and gives a brief description of the use of each item.

NOTE

Certain items of special test equipment listed in the chart below may be available in Maintenance Kit, Electronic Equipment MK-541/PPS4.

Test equipment	Reference	Use
* Afc Unit Bench Test Cable C XV121 /PPS , 4Pars 3-15	To connect afc unit to center section mounting plate.
* Audio Unit Bench Test Cable CX8123/PPS 4Para 3-15	To connect audio unit to center section mounting plate.
*F Amplifier Unit Bench Test Cable *CX1 2 4/PPSPara 3-15 4	To connect IF amplifier unit to center section mounting plate.
Power Converter Unit Bench Test Cable. CX81 22/PPS-4Para 3-15	To connect power converter unit to center section mounting plate.
* Range Unit Bench Test Cable CX119/PPS-4Para 3-15	To connect range unit to center section mounting plate.
Transmitter Unit Bench Test Cable IF Amplifier Unit Alignment CoverPara 8-16Fig. :3-3	To connect transmitter unit to center section mounting plate. To provide access to tuning adjustments for gain and bandwidth adjustment procedures and trouble shooting in the IF amplifier unit.
Terminated Test CablePara 3- 15	To apply a signal to IF amplifier unit between stages during alignment.
*Coaxial Cable 'BNC to Clip Lead CX8118/PPS-4Para 3-15	To connect afc crystal jack J9.(on microwave unit to dc meter for measurement of crystal current.
Clip Leads.....	To extend multimeter leads for making voltage measurements where convenient.

Test equipment	Reference	Use
* Coaxial Cable BNC to Banana Plug CX8117/PPS-4	Para 3-15	To connect sweep generator to variable attenuator for IF amplifier unit alignment and troubleshooting.
-Afc Unit to IF Amplifier Unit Test Cable. CG24Jo6/PFS-4	Para 3-15	To connect range mark circuit between IF amplifier unit and afc unit, when one of these units has been removed from center section during troubleshooting.
*Coaxial Cable with Amphenol Con- nectors (male-female). CG2497/PP S-4	Para 8-16	To troubleshoot IF amplifier unit and/or transmitter unit, and to connect blanking pulse from the transmitter unit to the IF amplifier unit input.
* Coaxial Cable with Amphenol Con- nectors (female-female). CX8120/PF PPS-4	Para 3-15	To troubleshoot IF amplifier unit and/or range unit. To connect IF amplifier unit to the range unit.
Corner Reflector	TM 11-5840-211-12	To conduct radar performance test.
Dummy Mixer	Fig. 3-4	To align and troubleshoot afc unit and IF amplifier unit.
Four-Layer Diode Tester	Para 3-10)	To test four-layer diodes CR608 of the audio unit, CR1002 of the strobe unit, CR204 of the transmitter unit.
* Coaxial Cable Uhf to Banana Plug - CX81 1 (PPS-4	Para 3-15	To connect the sweep generator to the horizontal input of the oscilloscope for IF amplifier unit alignment and troubleshooting.
Ground Plane	4-foot by 3-foot sheet of copper, 1/16 inch thick. Size is dependent upon placement of test equipment and size of work area,	To provide a ground for units being tested.
Group 'Strap	Birnback Co., No. 868 or equivalent. Length dependent upon arrangement of test equipment,	To connect test equipment and IF amplifier unit to ground plane.
Insulated Tuning Tools:		
Tool A	Cambridge Thermionic Corporation, Part No. 220.	To make tuning adjustments for the afc unit.
Tool B	Cambridge Thermionic Corporation, Part No. 0383.	To make tuning adjustments for the IF amplifier unit.
Plugs for Tip Jacks	Herman H. Smith, Inc. Part No. 200 or equivalent.	To permit access to test jacks with a voltmeter for voltage measurements and with an oscilloscope for wave form analysis.
Repair Pathcord	Para 3-15	To connect plug P101 to jack J101 when the control panel is separated from the receiver-transmitter center section.
Small Phone Plug and Wire	Herman H. Smith Inc., Part No. 480 or equivalent. No. 22 wire, 2 feet long.	To provide a connection between crystal current jacks on the IF amplifier unit and a dc meter.
		To permit measurement of crystal current during system alignment and troubleshooting.
Control Panel Support Fixture	Fig. 3-5	To prevent damage to control panel when separated from the radar set.
Test Capacitor	Ceramic 1,000 μμf capacitor with alligator clips soldered to each lead.	To align and troubleshoot the IF amplifier unit.
*Part of MIK-541/PPS-4Change 4		

Test equipment	Reference	Use
Test Resistor	Carbon, 33, 000 ohms, 1/4 watt	To provide isolation between test point E2 on the IF amplifier unit and the oscilloscope during IF amplifier unit alignment and troubleshooting.

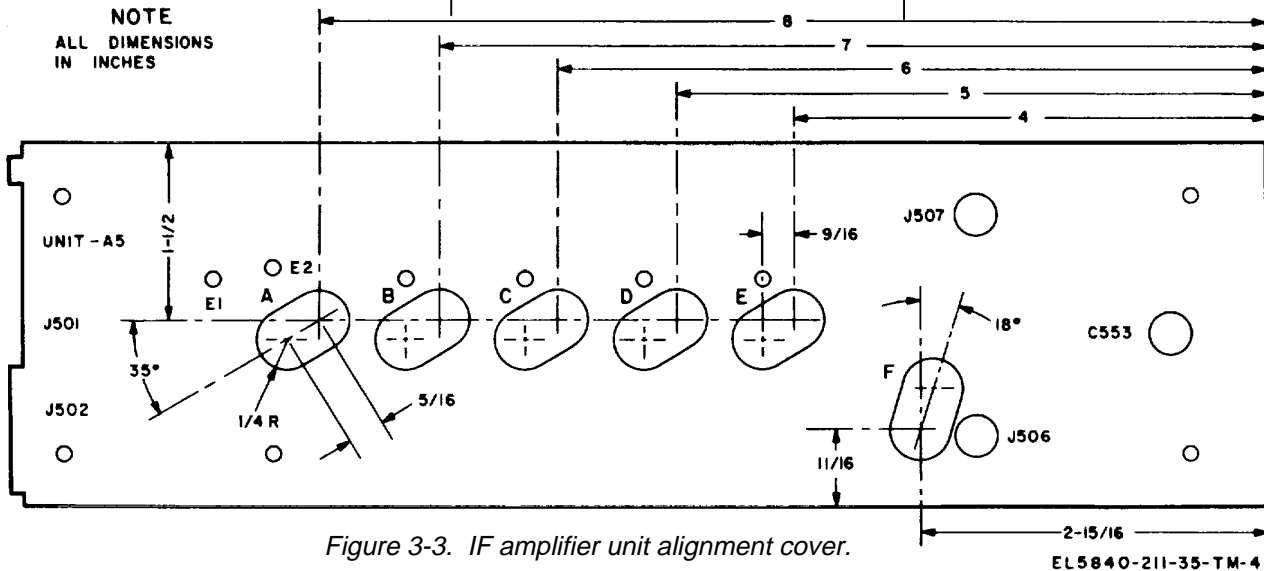

Figure 3-3. IF amplifier unit alignment cover.

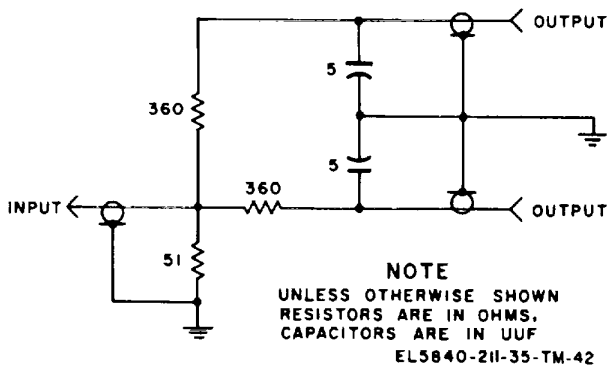

Figure 3-4. Dummy mixer, schematic diagram

3-15. Fabrication Information for Special Cables

The following chart lists the special cables required for testing and aligning Radar Set AN/ PPS-4A and provides the necessary information for fabricating the cables. Certain cables listed in the chart below may be available in Maintenance Kit, Electronic Equipment MK-541/PPS-4.

NOTE

All conductors are connected between corresponding pins of connector 1 and connector 2, and must be protected at each pin termination with a 1/2-inch length of sleeving.

Special cable	Conductors	Connectors	
		1	2
Afc Unit Bench Test Cable	7 conductors, No. 20 hookup wire. MILW-16878, type E, 18 inches long.	SM-D-336958-9	SM D-3370089
Audio Unit Bench Test Cable	14 conductors, No. 20 hookup wire; MIW-1678, type E, 18 inches long.	SM-D-102720-16	SM-D-1 02720-16'
IF Amplifier Unit Bench Test Cable.	7 conductors, No. 20 hookup wire; MIL-W-16878, type E; 18 inches long.	SM-CD 3369000	SM-C4336727-9 1

Special cable	Conductors	Connectors	
		1	2
	5935-00-729-0862	J701	5935-00-058-1641 P701
	5935-00-755-3426	P601	5935-00-735-3433 J601
	5935-00-754-8787	P501	5935-00-823-0769 J501
	5935-00-687-2205	J801	5935-00-474-6109 P801
	5935-00-755-3432	J401	5935-00-7553431 P401
	5935-00-754-8727	J201	5935-00-823-0769 P201
	5935-00-866-3010	J101	5935-00-617-8255 P101
	5330-00-650-9476		5935-00-655-4186 J206
	5330-00-640-9476		5330-00-640-9476

Special cable	Conductors	Connectors	
		1	2
Power Converter Unit Bench Test Cable.	.24 conductors, No. 20 hookup wire; MIL-W16878, type E; 18 inches long.	SM-D-336776-36	SM-C336855-36
Range Unit Bench Test Cable	.9 conductors, No. N2 hookup wire; MIL-W16878, type E; 18 inches long.	SM-D-3369583	SM-D-337008-3
Transmitter Unit Bench Test Cable	.9 conductors, No. 20 hookup wire; MILW-16878, type E; 18 inches long.	SM-C4369009	SM-C-336956
Repair Patchcord	.37 conductors, No. 20 hookup wire; MIL--W-16878, type E; 18 inches long.	SM-C-336855-50	SM-D-336776-50
Coaxial Cable with Amphenol Connectors (male-female).	RG-156/U, -MIL-C-1TB; 18 inches long.	SM-D-33'6959	SM-D-336956
Coaxial Cable with Amphenol Connectors (female-male).	RG-196/U, MI'17B; 18 inches long.	SM-D-336959.	SM-D-336959
Afc Unit to IF Amplifier Unit Test Cable.	RG-62/U, MIL-C 17B; .18 inches long.	MS-35170	FS-35171
Coaxial Cable BNC to Banana Plug	RG-62/U, MIL-C-17B, 18 inches long.	BNC (male)	General Radio Co., Type 274-MB.
Coaxial Cable BNC to Clip Leads	RG-2/U, -MIL-C-17B, 18 inches long.	Figure 3-6	
Terminated Test Cable	RG-58A/U, 2 feet long. Refer to A, figure 3-7.	Refer to B, figure 3-7.	
Coaxial Cable Uhf to Banana Plug	RG-62/U, MIL-C-17B, 18 inches long.	Amphenol, 83-ISP Type 974-MB.	General Radio Co.,

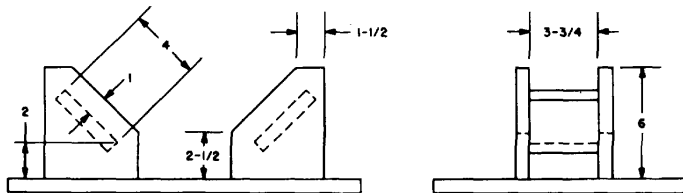
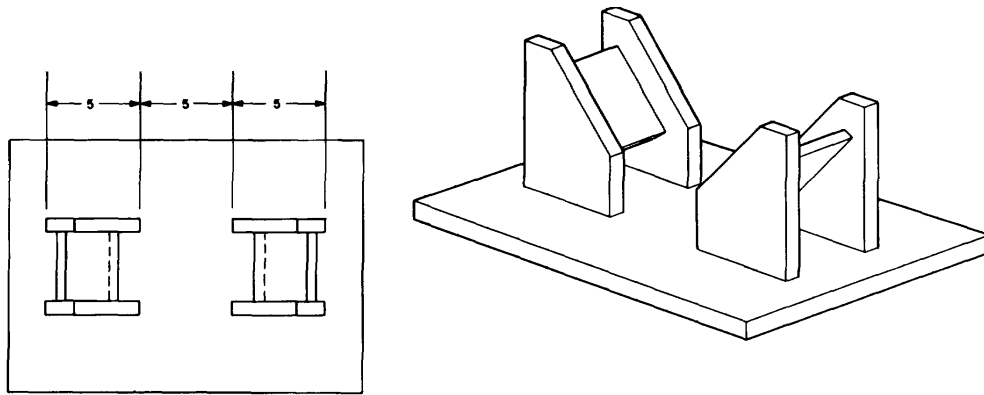

- NOTES**
1. TO BE FABRICATED FROM 3/4-INCH PLYWOOD.
 2. ALL DIMENSIONS IN INCHES.
 3. SIDES AND BOTTOM OF EACH SHELF LINED WITH SPONGE RUBBER GLUED TO PLYWOOD.

EL5840-211-35-TM-43

Figure 3-5. Control panel support feature
3-11

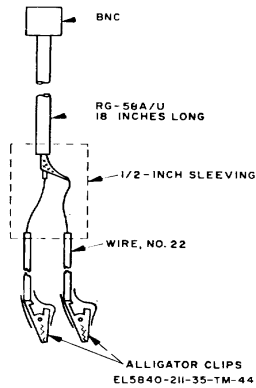
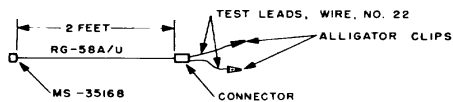
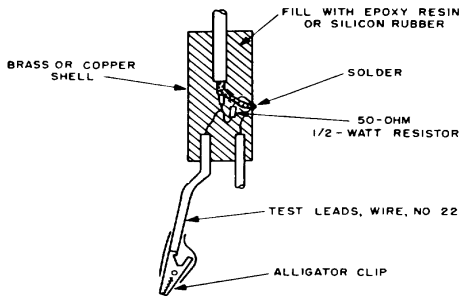

Figure 3-6. Coaxial cable BNC to clip load.



A. CABLE, BNC TO CLIP LEADS, TERMINATED IN 50-OHM RESISTOR



B DETAILED DRAWING OF CONNECTOR
EL5840-211-35-TM-45

Figure 3-7. Terminated test cable.

3-16. Troubleshooting Based on Starting Procedures

a. General. Troubleshooting based on starting procedures will aid in detecting the cause of abnormal operation of Radar Set AN/PPS-4A.

b. Preliminary Checks and Adjustments.

(1) Additional damage may be caused if power is applied to equipment in which a complete or partial short circuit exists. When any of the following conditions apply, check for short circuits before applying power to the radar set:

- (a) A replaced fuse has blown.
- (b) Smoke observed.
- (c) Overheated parts observed or smelled.
- (d) Abnormal symptoms reported from operational tests indicating the possibility of a partial or complete short circuit.

(2) Check the input power cable.

(3) Set the control panel switches as follows:

- (a) POWER switch S101 at OFF.
- (b) VOLTAGE ADJ switch S102 at position 1.
- (c) STROBE switch S105 at OFF.

c. Removal and Replacement of Control Panel.

(1) In order to perform items 11 and 12 of the troubleshooting chart, it is necessary to remove the control panel from the receiver-transmitter. Proceed as follows: set the POWER switch at OFF; release the four trunk-type latches that secure the control panel to the receiver-transmitter, and remove the control panel.

NOTE

Jack J101 on the receiver-transmitter and plug P101 on the control panel are separated when the control panel is removed.

CAUTION

Care should be taken in handling the control panel to prevent damage to meter M101 (fig. 3-8), strobe unit, and exposed wiring. Set the control panel in an upright position and secure it in place with the support fixture. Connect the repair patchcord between plug P101 at the bottom portion of the control panel (fig. 3-8) and jack J101 at the bottom of the receiver-transmitter center section (fig. 3-9). Use an oscilloscope at the test points indicated, and synchronize the oscilloscope from jack J1 of the range unit.

NOTE

In order to synchronize the oscilloscope, the radar set POWER switch must be set at TRANSMIT or RANGE.

(2) After completion of the troubleshooting procedures, perform the following procedures to reassemble the control panel to the receiver-transmitter.

(a) Make sure that the POWER switch is set at OFF. Remove the repair patchcord between plug P101 on the control panel (fig. 3-8) and jack J101 on the receiver-transmitter center section (fig. 3-9).

(b) Install the control panel on the receiver-transmitter by aligning the locating pin at the bottom of the control panel with the corresponding hole at the bottom of the center section and fastening the four trunk-type latches that secure the control panel in place.

Item No.	Trouble symptom	Probable trouble; checks; and corrective measures
1	RANGE EXTENSION METERS meter needle indicates zero or below half-scale deflection when the POWER switch is at TRANSMIT, STROBE switch is at OFF, VOLUME ADJ switch is at position 1 and the BATTERY TEST button is depressed and held after a delay of 90 seconds.	<ul style="list-style-type: none"> a. Defective external power supply. Set the VOLTAGE ADJ switch at positions 2 through 7 in progressive steps until the meter needle indicates in center of red zone. Check external power source; if battery is being used, it may be discharged. b. Defective POWER FUSE F102. Replace the blown POWER FUSE (TM 11-5840-211-12). c. Defective interlock switch Si. Check the interlock switch S1 (para 3-25). d. Defective power cable or connections. Check for continuity and for proper mating. e. Defective power converter unit. Check +r24-volt output of power converter unit. If +24-volt output is not present, refer to the power converter troubleshooting chart (para 3-24). f. Defective meter circuit. Check meter circuit components R1005, R1019, R1006, CR1006, CR1007 in the strobe unit and meter NI101. Replace faulty resistors or diodes. If meter M 101 is defective, refer the control panel to higher category of maintenance.
2	After 90-second delay, the RANGE EXTENSION METERS meter needle indicates less than 100 meters and no sound is heard in the headsets when the RANGE EXTENSION METERS indicator is set at R, 000 meters and VOLUME control is rotated to full clockwise position.	<p>Potentiometer R615 in the audio unit out-of-adjustment. Perform threshold adjustment (para 3-51). If symptoms persist, refer to agc system troubleshooting chart (para 313), receiving system troubleshooting chart (para 3-19), or ranging system troubleshooting chart (para 3M1). If corrective action corrects meter needle indication but no sound is heard in the headsets, refer to the audio system troubleshooting chart (para 3-29). If corrective action provides sound in the headsets, but does not correct the meter needle indication, check meter M101. Check the strobe unit of the ranging system; refer to the ranging system troubleshooting chart (para 3-21). If the rushing sound heard in the headsets varies approximately 5 Hz, refer to afc system troubleshooting chart (para 3-20).</p>
3	RANGE EXTENSION METERS meter needle does not deflect when range calibration procedures (TM 11-5840-211--2) are performed.	<ul style="list-style-type: none"> a. Potentiometer RL15 out-of-adjustment. Perform threshold adjustment (para 3-51). b. XMTR FUSE F101 blown. Replace blown XMTR FUSE F101. c. Afc system out-of-adjustment. Perform afc system adjustments (paras 340 and 3-41). d. Defective range mark circuit in afc system or no sweeping action. Refer to afc system troubleshooting chart (para 3-20). e. Defective age system. Refer to age system troubleshooting chart (para 3-23). f. Defective power cable or connections. Check power cable for continuity (TM 11-5840-211-12) and for proper mating. g. Defective ranging system. Refer to ranging system troubleshooting chart (para 3-21).

Item No.	Trouble symptom	Probable trouble; checks; and corrective measures
4	RANGE EXTENSION METERS meter needle deflection is very small when range calibration procedures (TM 11-5840-211-1-1) are performed.	<ul style="list-style-type: none"> a. Afc system out-of-adjustment. Perform afc system adjustments (paras 340 and 341). b. Defective afc system. Refer to the afc system troubleshooting chart (para 320).
5	No moving target sounds heard in headsets during radar performance test (TM 11-5840-211-12-).	<ul style="list-style-type: none"> a. Defective audio system. Refer to audio system troubleshooting chart (para -3-22). b. Defective afc system. Refer to afc system troubleshooting chart (para 3-20). c. Defective receiving system. Refer to receiving system troubleshooting chart (para '319). d. Defective ranging system. Refer to ranging system troubleshooting chart (para 3-21). e. Defective transmitting system. Refer to transmitting system troubleshooting chart (para 3-17).
6	RANGE EXTENSION METERS meter needle does not advance from 0 +50-10 meters to 50(0+10-50 meters in 4 to 6 seconds when the POWER switch is at TRANSMIT, the STROBE switch is at SHORT, and the RANGE METERS indicator is set to approximately 5, 000 meters adjustment.	<ul style="list-style-type: none"> a. Potentiometer R1035 in the strobe unit out-of-adjustment. Perform RANGE EXTENSION METERS meter zero adjustment R10, 25 (para 3-44). b. Potentiometer RQ1'7 in the strobe unit out-of-adjustment. Perform strobe amplitude adjustment (para 3-45). c. Potentiometer t11004 in the strobe unit out-of-adjustment. Perform strobe period adjustment (para 3-45). d. Defective STROBE switch S1(5. Check contacts of STROBE switch S105. If defective, remove and replace the control panel. Refer the defective control panel to higher category of maintenance. e. Defective meter M010I. Check for defective meter M101. If defective, remove and replace the control panel. Refer the defective control panel to higher category of maintenance. f. Defective ranging system. Check strobe unit of ranging system; refer to ranging system troubleshooting chart (para 3-21).
7	RANGE EXTENSION METERS meter needle does not advance from 0+W4-10 meters to '500 + 10-0 meters in 8 to 1'2 seconds when the POWER switch is at TRANSMIT, the STROBE switch is at LONG, and the RANGE METERS indicator is set to approximately 5, 000 meters.	Same as item 6 above.
8	RANGE EXTENSION METERS meter and RANGE METERS indicator lamps do not light or vary in brightness when the PANEL LIGHTS switch is rotated clockwise.	<ul style="list-style-type: none"> a. Defective lamps. Replace the defective lamps (TM 11-4021, t2). b. Defective resistor R104 or control knob. Check resistor R104, control knob, and switch S107. If defective; remove and replace the control panel. Refer the defective control panel to higher category of maintenance. c. Defective power converter system. Check 2.7-volt rms output of the power converter system at pin .10 of connector J101. If not present, refer to the power converter system troubleshooting chart (para S-24).
9	Tripod lamps do not light and vary in brightness when the TRIPOD LIGHTS switch is rotated clockwise.	<ul style="list-style-type: none"> a. Defective lamps. Check for defective lamps. Replace the defective lamps. If wiring is defective, remove and replace the control panel (para 3-59). Refer the defective control panel to higher category of maintenance. b. Defective resistor R106 or control knob. Check resistor P1106, control knob, and switch S10. If defective, remove and replace the control panel (para 3-59). Refer the defective control panel to higher category of maintenance. c. Defective tripod lamp cable or connection. Check tripod cable and connections.

Item No.	Trouble symptom	Probable trouble; checks; and corrective measures
10	Telescope reticule does not illuminate when the TELESCOPE LIGHT button is depressed.	a. Defective telescope lamp. Check telescope lamp; replace if defective (T:M 11-5840-21L1-t2). b. Defective telescope lamp cable or connection. Check for proper mating of lamp cable connector. c. Defective TELESCOPE LIGHT switch S103. Check switch 9103. If defective, remove and replace the control panel (para 3-9). Refer the defective control panel to higher category of maintenance.
11	Either no waveform is observed on oscilloscope or range gate waveform observed on oscilloscope does not move when STROBE switch is at OFF, and RANGE CONTROL handwheel is rotated. (Oscilloscope is connected to J404 on range unit.)	a. Wiring or range unit defective. Refer to ranging system troubleshooting chart (para 3-1). b. Defective potentiometer R103. Check potentiometer R103. If defective, remove and replace the control panel (para 3-59). Refer the defective control panel to higher category of maintenance. c. Defective potentiometers R10t, R102, and R107, or resistor B108. Check potentiometers R101, R102 and R107 and resistor R108. If defective, remove and replace the control panel (para 3-59). Refer the defective control panel to higher category of maintenance.
12	Less than 10 rangemarks appear on oscilloscope with POWER switch at RANGE and oscilloscope connected at J404 on range unit.	a. Afc system out-of-adjustment. Perform afc system tuning adjustment (paras 3-40 and 341). b. Defective receiving system. Refer to receiving system Troubleshooting chart.

3-17. Transmitting System Troubleshooting

connecting the magnetron with the pulse unit.

WARNING

Extremely dangerous voltages exist in the transmitting system of Radar Set AN/PPS-4A. High voltages are developed in pulse unit Z201, on magnetron V901, and on the cable

a. Dc Resistance of Transformers, Coils, and Relays in Transmitting System. The following chart lists the transformers, coils, and relays in the transmitting system:

Transformer, coil, or relay	Location Fig. No.	Terminals Terminals	DC Resistance (ohms)
K201	3-14	2-3	150 max
K202	3-14	1-5	15K max
Z201 charging choke	3-14	5-10	20 max
Z201 pulse transformer, primary		2-6	0.02 max
Z211 pulse transformer, secondary		1-8	2.10 max
Z201 bifilar secondary (II)		3-9	2.20 max
Z201 range trigger winding		4-11	0.02max

b. Transmitting System Waveforms. Waveforms obtained during performance of troubleshooting procedures should be as illustrated in figure 3-11. If the desired waveform is not obtained, proceed as directed in the troubleshooting procedures.

(1) Release the four trunk-type latches that fasten the control panel on the receiver-transmitter, and remove the control panel.

WARNING

Before following the procedure below, check to see that POWER switch S101 is in the OFF position.

CAUTION

Care should be taken in handling the control panel to prevent damage to meter M101, the strobe unit, and exposed soldered connections.

c. Preparation of System Components for Troubleshooting. To make the transmitting system accessible for troubleshooting or alignment

(2) Place the Control panel in the support fixture.

(3) Connect the repair patch cord between plug P101 on the control panel and receptacle J101 on the rear of the center section.

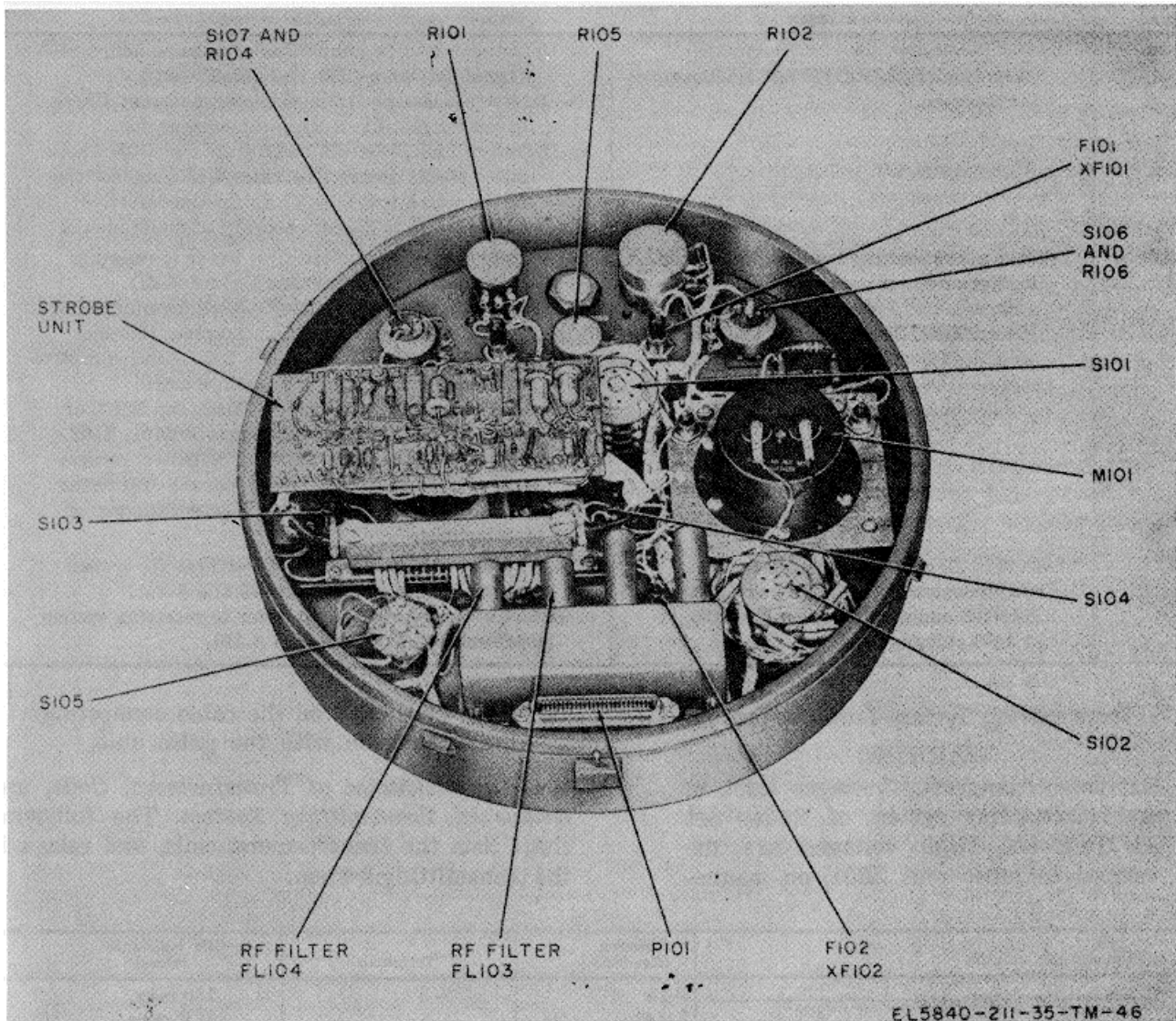

Figure 3-8. Strobe unit on rear of control panel

(4) Release the four trunk-type latches that fasten the front section (radome) on the receiver transmitter, and remove the radome.

CAUTION

Care should be taken to prevent denting the reflector or damaging the dipoles of the antenna feed.

(5) Disable interlock switch S1 (fig. 3-1) by pulling the interlock shaft to the full forward position. Refer to the warning notice in paragraph 3-7.

(6) Remove the cover of the transmitter unit by unscrewing four binding head screws, and lifting off the cover (fig. 3-12).

(7) Remove the antenna feed assembly (fig. 3-1) from hybrid waveguide assembly No. 1 by

removing the four No. 8-32 x 1/2 binding head screws and four No. 8 lockwashers from the antenna feed assembly flange.

(8) Secure the dummy antenna to the flange of hybrid waveguide assembly No. 1 with the four No. 8-32 x 1/2 binding head screws and four No. 8 lockwashers removed in (7) above

NOTE

When it is necessary to make voltage measurements in the transmitter unit, perform (9) below.

(9) Remove the transmitter unit from the center section of the receiver-transmitter (para 361). Connect the transmitter bench test cable between plug P201 on the transmitter unit and jack J201 (fig. 3-13) on the center section plate.

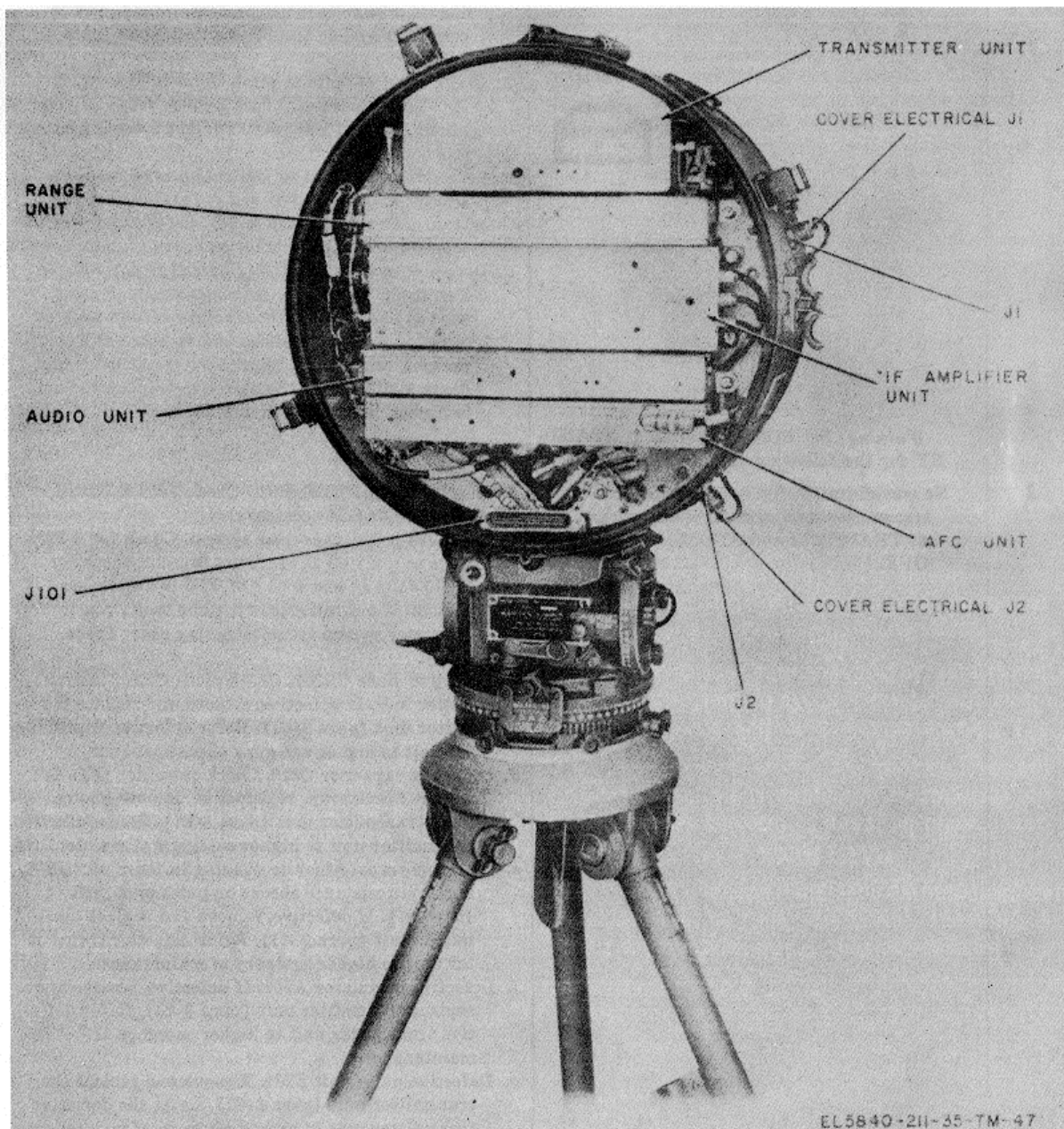

Figure 3-9. Receiver-transmitter, center section, rear side.

d. Transmitting System Troubleshooting Chart.

WARNING

Extremely dangerous voltages exist in the transmitting system. Positive 270 volts exists at pulse unit Z201 and at modulator A201. Voltages from 300 to 5, 000 volts are developed in pulse unit Z201.

Item No.	Trouble symptom	Probable trouble; checks; and corrective measures
1	No waveform (A, fig. 3-11) at pin 2 of modulator A201 on the transmitter unit with POWER switch at TRANSMIT and STROBE switch at OFF.	a. Defective power converter system. Check for +24 volts at local oscillator circuit board (fig. 3-13). If +214 volts is not present, check for +124 volts at terminal 6 of TB1 in the center section (fig. 3-

Item	Trouble symptom	Probable trouble; checks; and corrective measures
2	<p>Warning: Set POWER switch at STANDBY for the following checks in item 2. No waveform (B, fig. ~3-1i1) at J203 on transmitter unit with POWER switch at TRANSMIT and 1STROBE switch at OFF.</p>	<p>13). If + 24 volts is not present, refer to power converter system troubleshooting chart (para 8-24).</p> <p>b. Check for +24 volts at pin 1 on modulator A201. If +24 volts is not present, check for +24 volts at pins 1 and 8 of relay K2012. If not present proceed to c below.</p> <p>c. Defective relay K11 or K202. Check relays KCO1 and K201. If defective, remove and replace the transmitter unit (para 3-61). Refer the defective transmitter unit to higher category of maintenance.</p> <p>d. Defective modulator A20. Check waveform at pin 8 on modulator A201 (negative 2 volts, 5 μsecs wide at baseline). If satisfactory results were obtained in a, b, and c above and no waveform is present, remove and replace the transmitter unit (para 3-61). Refer the defective transmitter unit to higher category of maintenance.</p> <p>a. Blown XMTR FUSE F101. Check XMTR FUSE F101; replace if necessary.</p> <p>b. Defective power converter system. Check for +270 volts at pin 5 on Z201. If not present, check for +270 volts at terminal 4 of TB1 in the center section. If not satisfactory, refer to the power converter system troubleshooting chart (para 3-24).</p> <p>c. Defective diode CR2C. Check diode CR203 in transmitter unit. If defective, remove and replace transmitter unit to higher category of maintenance.</p> <p>d. Defective capacitor 0216. Check capacitor 0216 for voltage breakdown. If defective, remove and replace transmitter unit (para 3-61). Refer defective transmitter unit to higher category of maintenance.</p> <p>e. Defective transformer or winding in pulse unit Z201. Perform resistance checks on pulse unit Z201 (a above). If defective, remove and replace transmitter unit (para 3-61). Refer defective transmitter unit to higher category of maintenance.</p> <p>f. Defective modulator A201. If defective, remove and replace transmitter unit (para 3-1). Refer defective transmitter unit to higher category of maintenance.</p> <p>g. Defective pulse unit Z201. Remove and replace the transmitter unit (para 34). Refer the defective transmitter unit to higher category of maintenance.</p>
3	<p>Pulse width is greater or less than 0.2 +0.02 μsec of 50%/c points at directional coupler J908 (fig. 3-1) with PLOWER switch at TRANSMIT and STROBE switch at OFF.</p>	<p>a. Defective power converter system. Check for +270 +1 volts at terminal 4 of TB1 in the center section. If not satisfactory, refer to the power converter system troubleshooting chart (para 3-24).</p> <p>b. Potentiometer R207 out-of-adjustment. Check for +0.4 to +1.7 volt at jacks J204 and J205 on the transmitter unit. If voltage is not correct, adjust potentiometer R207 to obtain proper pulse width (para 3--2).</p> <p>c. Defective pulse unit Z'201. Remove and replace the transmitter unit and refer the transmitter unit to higher category of maintenance for repair. If replacement of the transmitter unit does not correct the trouble, proceed to step d below.</p> <p>d. Defective magnetron V9011. Replace magnetron V901 (para 3-7).</p>

Item No.	Trouble symptom	Probable trouble; checks; and corrective measures
4	Power output is greater or less than 27-30 dbm at directional coupler J908 with POWER switch at TRANSMIT and STROBE switch at OFF.	a. Pulse repetition rate unsatisfactory. Perform pulse repetition rate adjustment (para 3-32). b. Defective magnetron V901. Replace magnetron V901 (para 3-67).
5	Pulses are missing in the frequency spectrum with 10-MHz bandwidth when the POWER switch is at TRANSMIT and the STROBE switch is at OFF.	Defective magnetron V901. Replace magnetron V901, (para 3-67).
6	No waveform (C, fig. 3-1s1) at the junction of CRe65 and C05 (fig. 3-14) on rear of Circuit board with the POWER switch at TRANSMIT and the STROBE switch at OFF.	a. Defective transistor QW1. Remove and replace the transmitter unit (para 3-61). Refer the defective transmitter unit to higher category of maintenance. b. Defective pulse unit Z01. Check output at jack J206 (fig. 3-12) with oscilloscope. A negative waveform, , 5 to 70 volts in amplitude, should be present. If waveform is not present, remove and replace the transmitter unit. Refer the transmitter unit to higher category of maintenance.

3-18. RF System Troubleshooting

a. *General.* The RF system troubleshooting chart is based on operation of the radar set in an area having stationary targets at close range.

Item No.	Trouble symptom	Probable trouble; checks; and corrective measures
1	Target echoes from the close stationary targets are extremely weak.	Defective dual-channel limiter. Replace the dual-channel limiter (para 3-48).
2	Crystals CR901 and OR90 buried out	Defective dual-channel limiter. Replace the dual-channel limiter (para 3--8) and crystals CR901 and CR902 (para 3-69).
3	Target echoes are weaker than those normally obtained.	a. Low magnetron output. Refer to transmitting system troubleshooting chart (para 3-17). b. Misalignment of afc system. Refer to afc system troubleshooting chart (para 3-20). c. Defective or unbalanced signal mixer crystals. Refer to receiving system troubleshooting chart (para 8-19). d. Damaged antenna feed assembly. Replace antenna feed assembly (para 3-68). e. Foreign matter in RF system waveguide. Disassemble and clean RF system (para 3-68). f. Misaligned or defective signal IF amplifiers. Refer to receiving systems troubleshooting chart (para 3-19).

3-19. Receiving System Troubleshooting

a. *Controls and Adjustments.* The following chart lists the controls and adjustments that are functional parts of the receiving system:

Controls and adjustments	Location (fig. no.)	Function
L526, L525, 524 L523, L522, _____ L510, L507. _____	3-16	Primary tuning inductors for IF amplifiers.
L521, L535, L536, L537, L538, L539 _____	3-16	Secondary tuning inductors for IF amplifiers.
C533, C526, C524, C521, C515, C576 _____ C553 _____	3-16 3-15	Variable coupling capacitors for IF amplifiers. Secondary tuning capacitor for IF amplifiers.
Tuning knob of klystron V902 _____	3-1	Adjusts the size of the cavity in the headsets.
VOLUME control R105 _____	3-8	Adjusts level of signal heard in headsets.
	TM 11-5840-211-12	

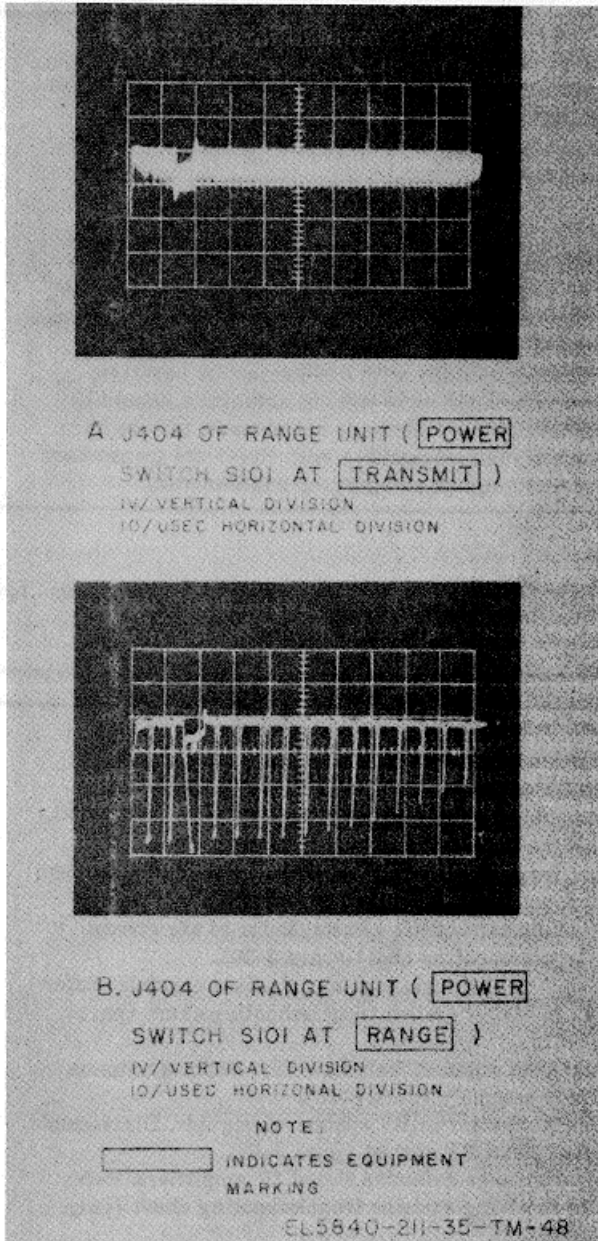
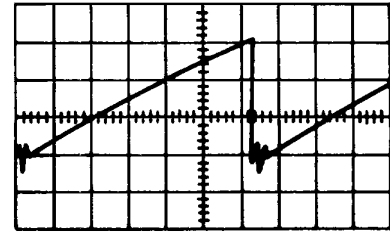
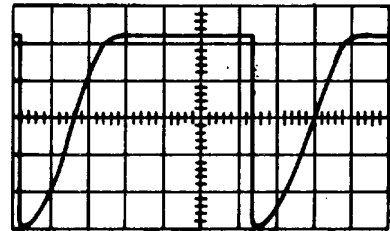

Figure 3-10. Waveforms for troubleshooting based on starting procedures.

b. Normal Indications at Receiving System Test Jacks. Test jacks J506 and J507 (fig. 3-3) provide a means for measuring the current for signal mixer crystals CR901 and CR902. The normal current measured (crystal current sweeps) is between 0.5 and 1.0 milliamperes at each test jack. In-lock current is variable with the position of the range gate.



A. PIN 2, MODULATOR A201
 2V/VERTICAL DIVISION
 50 USEC/HORIZONTAL DIVISION



B. J203
 100V/VERTICAL DIVISION
 50 USEC/HORIZONTAL DIVISION

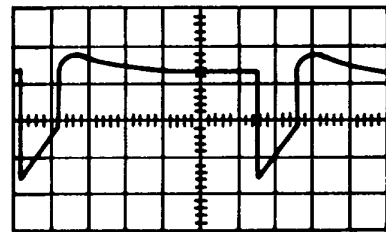

C. E213
 10V/VERTICAL DIVISION
 50 USEC/HORIZONTAL DIVISION
 EL5840-211-35-TM-49

Figure 3-11. Transmitting system waveforms.

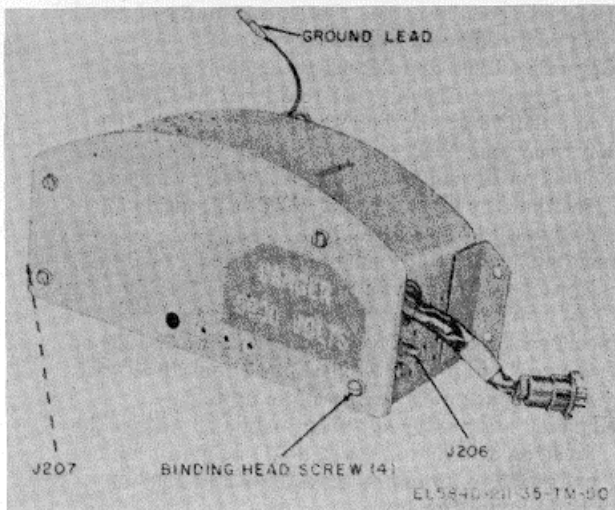

Figure 3-12. Transmitter unit, cover attached.

tron, and the signal mixer crystals. The IF amplifier unit is located on the rear of the center section of the receiver-transmitter (fig. 3-9). The klystron and the signal mixer crystals are attached to the microwave assembly which is located on the front section of the receiver transmitter (fig. 3-1).

WARNING

Before following the procedures described below, make sure that the POWER switch is in the OFF position.

CAUTION

Care should be taken in handling the control panel to prevent damage to meter M101, the strobe unit, and exposed soldered connections.

(2) To make the receiving system accessible for troubleshooting, proceed as follows: (a) Release the four trunk-type latches that fasten the control panel on the receiver transmitter, and remove the control panel.

CAUTION

Care should be taken to prevent denting the reflector or damaging the dipoles of the antenna feed.

(b) Release the four trunk-type latches that , fasten the front section (radome) on the receiver-transmitter, and remove the radome with the reflector attached.

(c) Place the control panel in the support fixture.

(d) Connect the repair patch cord between plug P101 on the control panel and jack J101 on the center section.

(e) Disable interlock switch S1 (fig. 3-1) by pulling the interlock shaft to the full forward position. Refer to warning notice in paragraph 3-7.

f. Receiving System Troubleshooting Chart.

c. *Dc Resistance of Coils.* The following chart lists the coils in the receiving system, references a figure that shows the location of each, and gives the dc resistance of every winding:

Coil	Location (fig. no.)	Maximum dc resistance (ohms)
L501 through L511	3-16	1
L513, L514	3-16	1
L515 through L520	3-17	1
L521 through L526	3-16	1
L529 through L532	3-16	1
L535 through L539	3-16	1
L-533, L534, L540	3-16	5
L541, L544	3-16	5
L542, L543	3-17	1

d. *Waveforms.* Figures 3-19 and 3-20 illustrate waveforms for a normal receiving system.

e. *Preparation of System Components for Troubleshooting.*

(1) The receiving system consists of the components in the IF amplifier unit, the klys

Item No.	Trouble symptom	Probable trouble; checks; and corrective measures
1	Crystal currents at jacks J506 and J507 on the IF amplifier unit have the same polarity with the POWER switch at TRANSMIT.	Defective crystals CR901 and CR902 in the microwave assembly. Remove crystals CR901 and CR902 and insert crystals designated on the stencil next to the crystal holder (para 8).
2	No current at either jack J606 or J507 on the IF amplifier unit with the POWER switch at TRANISMIT.	a. Plugs P504 and P505 which terminate the coaxial cables attached to the IF amplifier unit are not connected to jacks J905 and J906 on hybrid waveguide assembly No. 2 (fig. 3-, t). Check to see that plugs P504 and P505 are properly connected to jacks J905 and J906.

Item No.	Trouble symptom	Probable trouble; checks; and corrective measures
3	Current at only jack J506 or J507 on the IF amplifier unit with the POWER switch at TRANSMIT.	<ul style="list-style-type: none"> b. Defective coaxial cables. Check continuity of coaxial cables; replace if defective. c. Crystals CR901 and CR902 not in their respective receptacles. Check to see that crystals CR901 and CR902 are in their receptacles. d. Klystron plug P902 not connected to klystron jack J902 on hybrid waveguide assembly. Check to see that the klystron plug P902 is properly connected to jack J902. e. Incorrect voltage at klystron anode (outer case of klystron). With a multimeter, check for 260 (+t0, -0) volts at the outer case of klystron. f. Incorrect klystron reflector voltage at jack J604 on the audio unit (fig. 3-58). Check for -70 to -145 volts at jack J604 on the audio unit. g. Klystron attenuator out-of-adjustment, Adjust the klystron attenuator (para 3-41) to obtain an output of 0.5 to 1.0 ma at jacks J506 and J507 on the IF amplifier unit. a. Plug P504 or P505 not connected to jacks J905 or J906 (2a above). Check to see that plugs P504 and P505 are connected to jacks J905 and J906. b. Defective coaxial cables (2b above). Check continuity of coaxial cables; replace if defective. c. Crystals CR901 and CR902 not in receptacles. Check to see that crystals CR901 and CR902 are in their receptacles. d. Defective crystals CR901 and CR9(Y2. Check crystals CR901 and CR902; replace if defective. e. Defective capacitors C549, C504, C503 (fig. 3-15). If there still is no current at jack 3J507 on the IF amplifier unit, disconnect the milliammeter from the phone plug cord; check to see that the plug on the phone plug is inserted in jack J507 on the IF amplifier unit. One wire from the phone plug cord should measure continuity from the center conductor of plug P504 on the IF amplifier unit; the other wire should measure continuity to ground. If they do not, remove and replace the IF amplifier unit and refer the defective IF amplifier unit to higher maintenance category for repair. f. Defective capacitors C550, C506, C505 (fig. 3-15), or inductors L513, L504, and L503 (fig. 3-6). If there still is no current at jack J506 on the IF amplifier unit, disconnect the millimeter from the phone plug cord; check to see that the plug on the phone plug is inserted into jack J506 on the IF amplifier unit. One wire from the phone plug cord should measure continuity to the center conductor of plug P505 on the IF amplifier unit; the other wire should measure continuity to ground. If they do not, remove and replace the IF amplifier unit and refer the defective IF amplifier unit to higher maintenance category for repair.
4	Current at jacks J506 and J507 on the IF amplifier unit is less than 0.4 ma with POWER switch at TRANSMIT.	<ul style="list-style-type: none"> a. Klystron requires tuning. Tune the klystron (para 3-41). b. Klystron attenuator out of adjustment. Adjust the klystron attenuator (para 3-41) to obtain a crystal current of 0.5 to 1.0 ma. c. Incorrect voltages being applied to the klystron. Check to see that 6.3 volts rms, +, 250 volts, and the negative dc voltages are being supplied to the klystron.

Item No.	Trouble symptom	Probable trouble; checks; and corrective measures
5	<p>Current at Jacks J5N0 and J507 on the IF amplifier unit is greater than 1.1 ma. with POWER switch at TRANSMIT.</p> <p><i>Note.</i> Install the IF amplifier unit alignment cover (para 8-14) on the IF amplifier unit. Connect the oscilloscope vertical input to J408 and sync Input to J401 on the range unit.</p>	<p>d. Crystals CR901 and CR902 defective. Check crystals CR901 and CR902; replace if defective.</p> <p>e. Defective klystron. If the klystron does not tune properly remove and replace the klystron (para 3-68).</p> <p>Local oscillator attenuator out of adjustment. Adjust the local oscillator attenuator (para 3-41).</p>
6	<p>No transmitter pulse and no receiver noise (fig. 3-19) at jacks J403 and J4(01 on range unit (fig. 3-56) will the POWER switch at TRANSMIT, the RANGE METERS indicator at the value specified on the RANGE CALIBRATION plate for the 7th MARK, and the VOLUME control rotated fully clockwise,</p>	<p>a. Defective power converter system. Insert one lead of a 33, 000-ohm resistor into test point E2 (IF amplifier unit alignment cover). Connect the other lead of the 33, 000 - ohm resistor to the oscilloscope probe. Check for an inverted version of the waveform (fig. S-19) at test point E2. If the waveform is not present, disconnect plug P501 from the IF amplifier unit and check for +120, +24, and -20 volts de, 6.3 volts ac rms, and agc voltage at appropriate terminals of TB1 (para 3-4). If the voltages are not present, refer to the power converter system troubleshooting chart (para 3-24).</p> <p>b. Defective age system. If the age voltage cannot be adjusted between 2.5 and 5.5 volts by varying VOLUME control R105, refer to the age system troubleshooting chart (para 3-23).</p> <p>c. Defective interconnecting cable between the range unit and the IF amplifier unit. Disconnect plug P407 from the range unit and jack J6502 from the IF amplifier unit and check the interconnecting cable for continuity; replace the defective cable.</p> <p>d. Defective IF amplifier unit. Remove and replace the IF amplifier unit (para -63). Refer the defective IF amplifier unit to higher category of maintenance.</p>
7	<p>Transmitter pulse displayed on the oscilloscope but no receiver noise (fig. 3-19) at jacks J403 and J401 on range unit (fig. 3-55) with the POWER switch at TRANSMIT, the RANGE METERS indicator at the volume specified on the 7th MARK, and the VOLUME control rotated fully clockwise.</p>	<p>a. Volume control R105 out of adjustment. Check VOLUME control R105 adjustment (para 3-49). If 1.065 is defective, remove and replace the control panel (para 3-59). Refer the defective control panel to higher category of maintenance.</p> <p>b. Defective IF amplifier unit. Remove and replace the IF amplifier unit (para 3-63). Refer the defective IF amplifier unit to higher category of maintenance.</p>
8	<p>Transmitted pulse approximately 2 μsec wide at jacks J403 and J401 on the range unit (fig. 3-55) with the P POWER switch at TRANSMIT and the RANGE METERS indicator at the value specified on the 7th MARK.</p>	<p>a. Defective transmitter unit. Disconnect plug P508 from jack J206 on the transmitter unit. With oscilloscope, measure the blanking pulse at jack J206. The pulse should be between 54 and 70 volts. If not, refer to the transmitting system troubleshooting chart (para 3-17).</p> <p>b. Defective blanking pulse subchassis. Remove and replace the IF amplifier unit (para 3-63). Refer defective IF amplifier unit to higher category of maintenance.</p>
9	<p>Transmitter pulse displayed but no rangemarks observed on the oscilloscope (waveguide fig. 3 20) at jacks J403 and J401 of the range unit (fig. 53i5) with the POWER switch at RANGE and the RANGE METERS indicator at the value specified on the RANGE CALIBRATION plate for the 7th MARK.</p>	<p>a. Defective interconnection cable. Remove plug P503 from jack J702 on the afc unit and check the cable.</p> <p>b. Afc system out of alignment. Refer to afc system alignment procedures (para 3-38).</p>

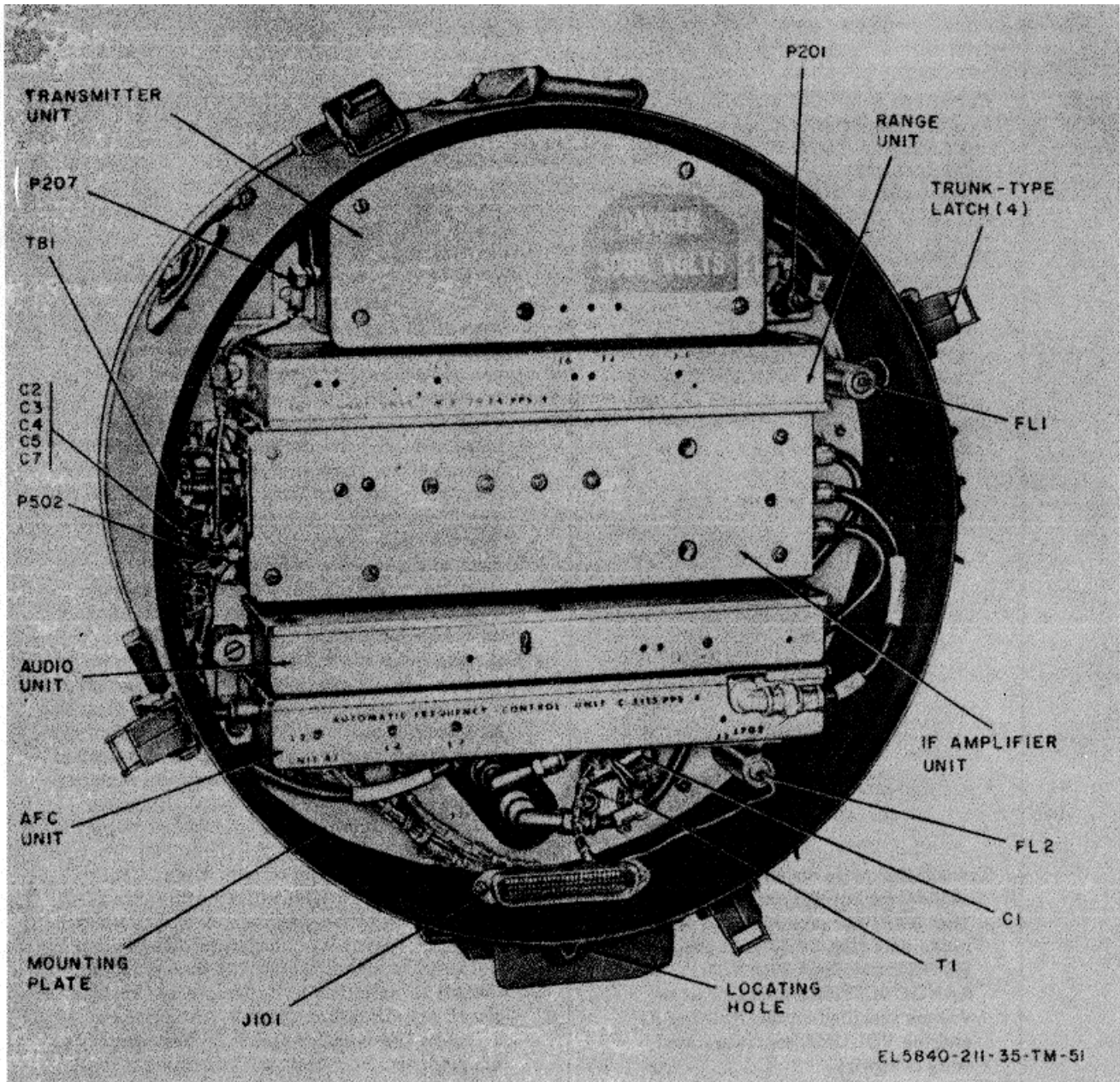

Figure 3-13. Receiver-transmitter, rear side, panel removed.

3-20. Automatic Frequency Control System Troubleshooting

chart lists the controls and adjustments that are functional parts of the afc system.

a. *Controls and Adjustments.* The following

Controls and adjustments	Location (fig. no.)	Function
AFC/MFC switch S601	3-58	Selects automatic frequency control or manual frequency control of local oscillator
Potentiometer R632	3-58	Controls the reflector voltage of klystron local oscillator V902
Klystron tuning knob	3-50	Controls the frequency of oscillation of klystron local oscillator V902

Controls and adjustments	Location (fig. no.)	Function
MAG. TUNER	3-50	Controls the frequency of oscillation of magnetron V901
Inductors L702, L704, and L707	3-59	Tune the af IF amplifier and afc discriminator

b. *Normal Voltages at Test Points in the 4, fc System.* The following chart lists normal voltages at test points in the afc system:

Test point	Location (fig. no.)	Normal voltage to ground
708	3-25	-1 to 1.6
E709	3-25	0 to -0.5
E713	3-25	0
E717	3-25	22.8 to 25.2(power switch at range).
E719	3-25	114 to 126
E720	3-25	0
E721	3-25	0
E722	3-25	0
E724	3-25	0
E726	3-25	0
E729	3-25	114 to 126
E731	3-25	-19 to -21
E601	3-26	-145 to -158.3
E604	3-26	-145 to -150
E623	3-26	-6 to -11

c. *Dc Resistance of Coils and Relays in the Afc System.* The following table lists the coils and relay in the afc system, references a figure that shows the location of each, and gives the dc resistance of every winding

Coil or relay	Location (fig. no)	Terminals,	Maximum de resistance (ohms)
L701	3-22		1
L702	3-22		1
L703	3-22		1
L704	3-22		1
L705	3-22		1
L706	3-22		1
L707	3-22		1
K701	3-22	3 and 7	600 and 700

d. *Waveforms.* Waveforms for a normal afc system are illustrated in figures 3-27 through 3-30

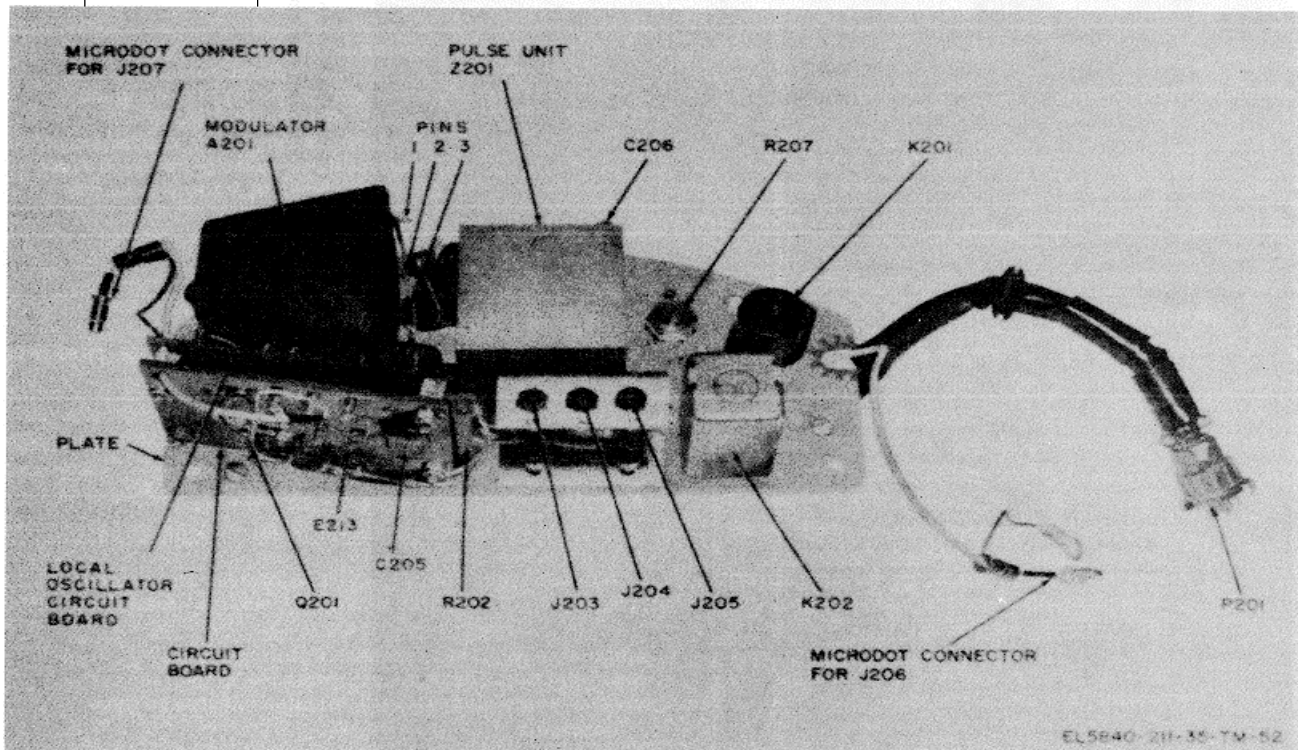

Figure 3-14. Transmitter unit removed from chassis.

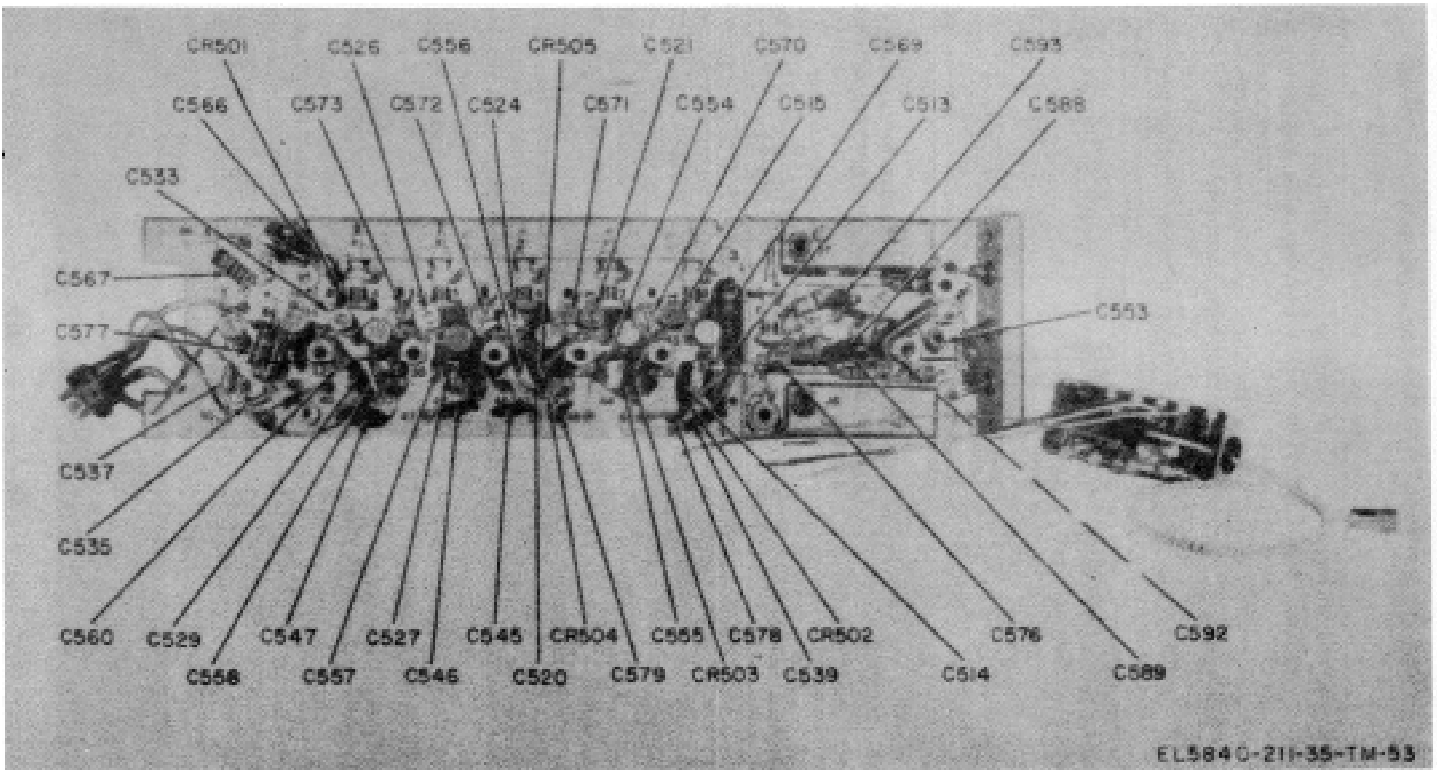

Figure 3-15. IF amplifier unit circuit board capacitors and diodes.

Change 1, 3-26

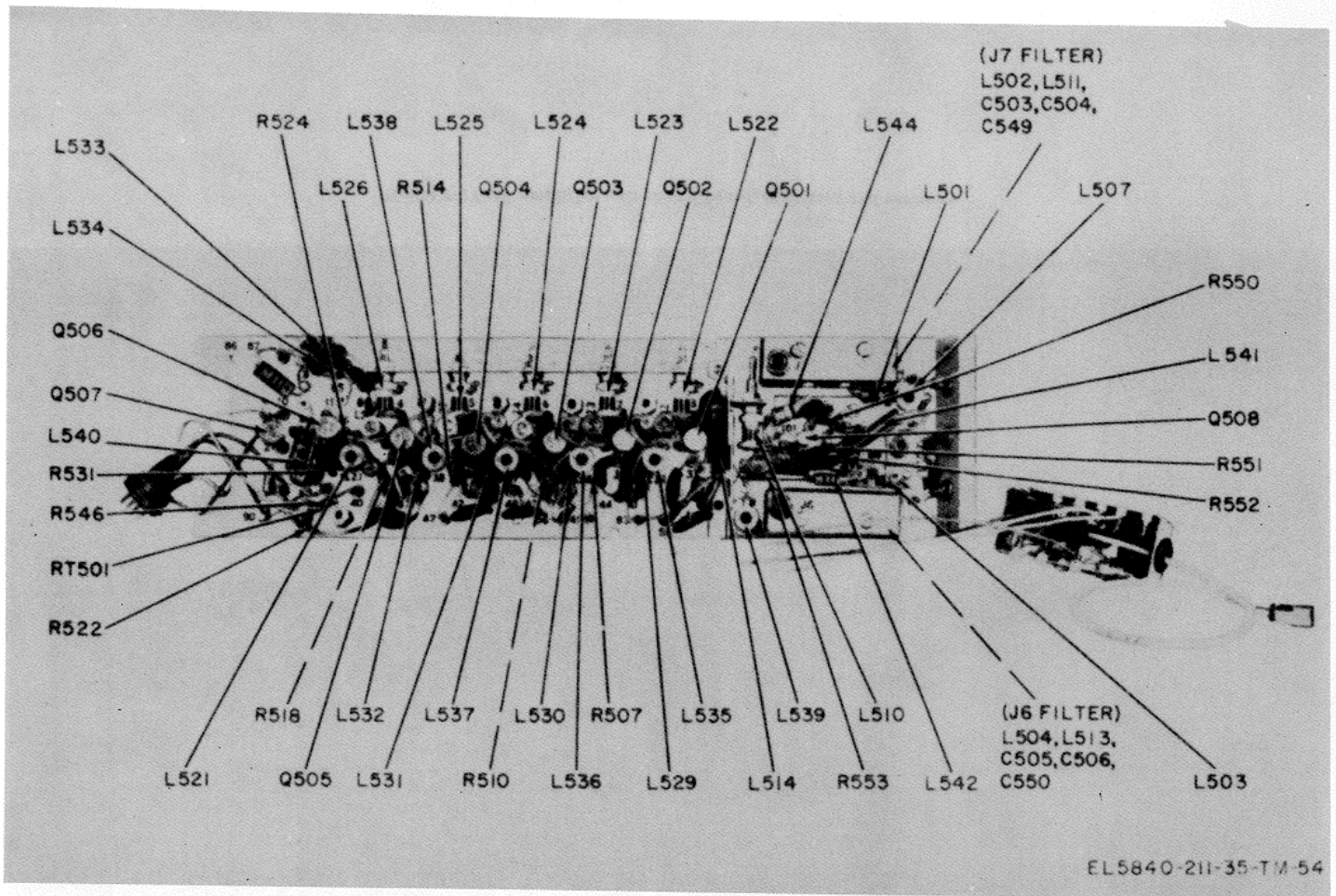

Figure 3-16. IF amplifier unit circuit board, inductors, resistors, and transistors.

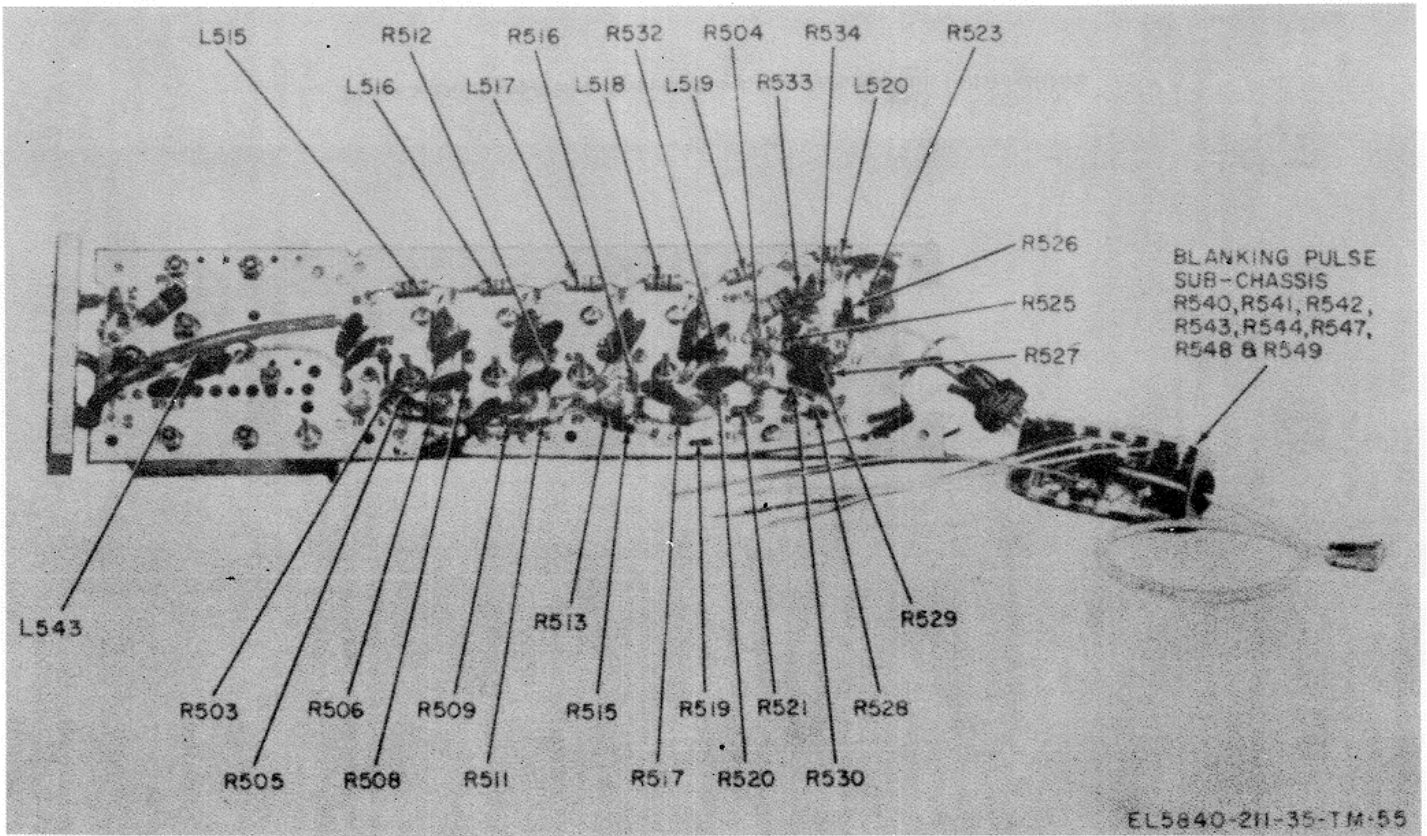

Figure 3-17. IF amplifier unit circuit board, inductors and resistors.

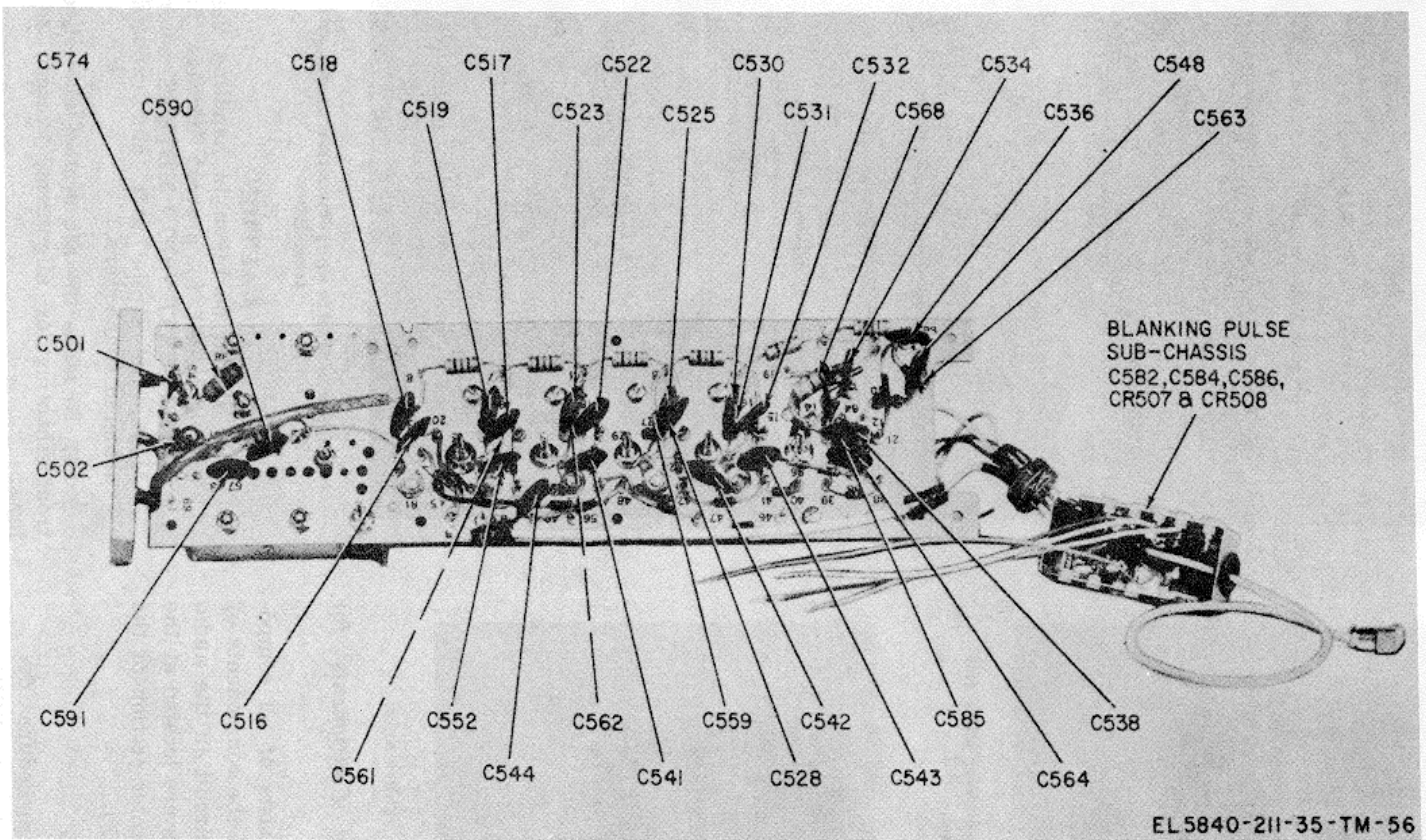

Figure 3-18. IF amplifier unit circuit board, rear view, capacitors.

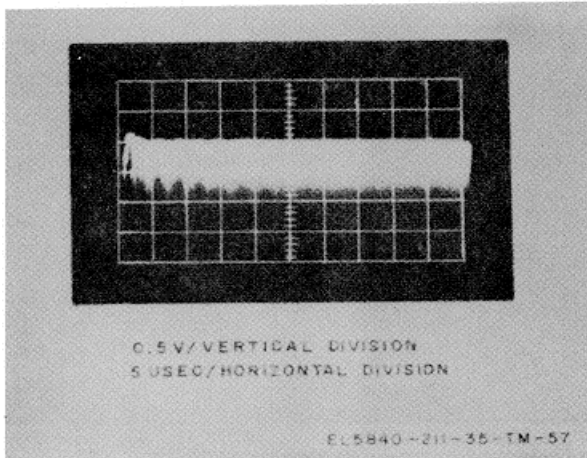

Figure 3-19. Waveform, transmitter pulse and receiver noise.

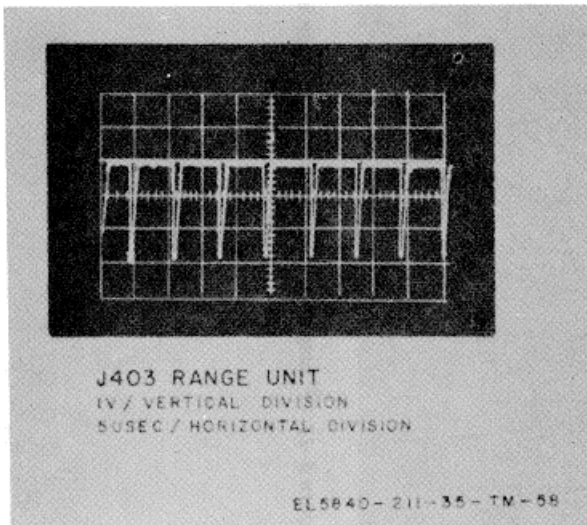

Figure 3-20. Waveform, rangemarks,

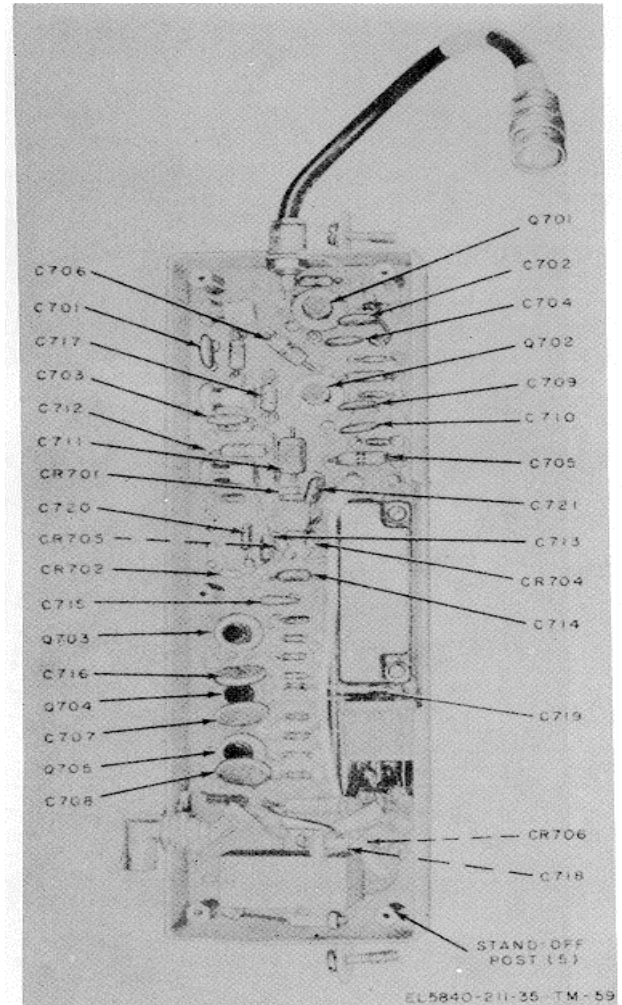

Figure 3-21. Afc Unit, capacitors, diodes, and transistors.

e. Preparation of System Components for Troubleshooting.

(1) The afc system consists of all components in the afc unit and all the components of the afc search and control circuit in the audio unit. The afc and audio units are located at the bottom rear portion of the center section of the receiver-transmitter (fig. 3-13).

WARNING

Before following the procedure described below, make sure that the POWER switch is in the OFF position.

CAUTION

Care should be taken in handling the control panel to prevent damage to RANGE EXTENSION METERS meter MI101, the strobe unit, and exposed soldered connections.

(2) To make the afc system accessible for troubleshooting or alignment, proceed as follows:

- (a) Release the four trunk-type latches (fig. 3-13), that secure the control panel to the

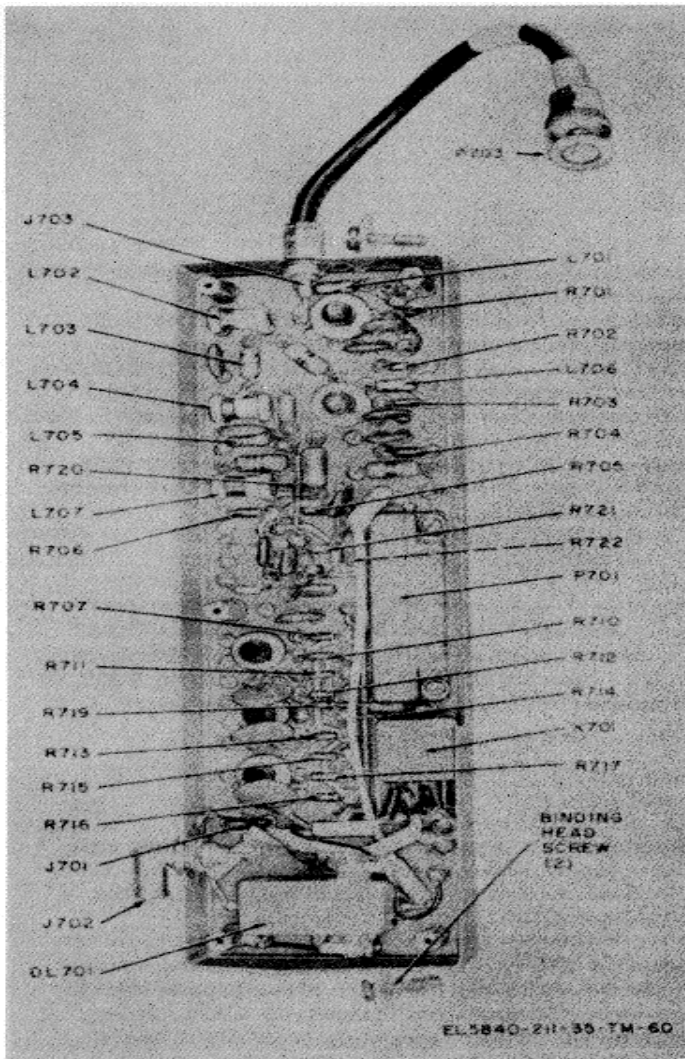

Figure 3-22. Afc unit, resistors and inductors

receiver-transmitter housing. Remove the control panel, and place it in the support fixture.

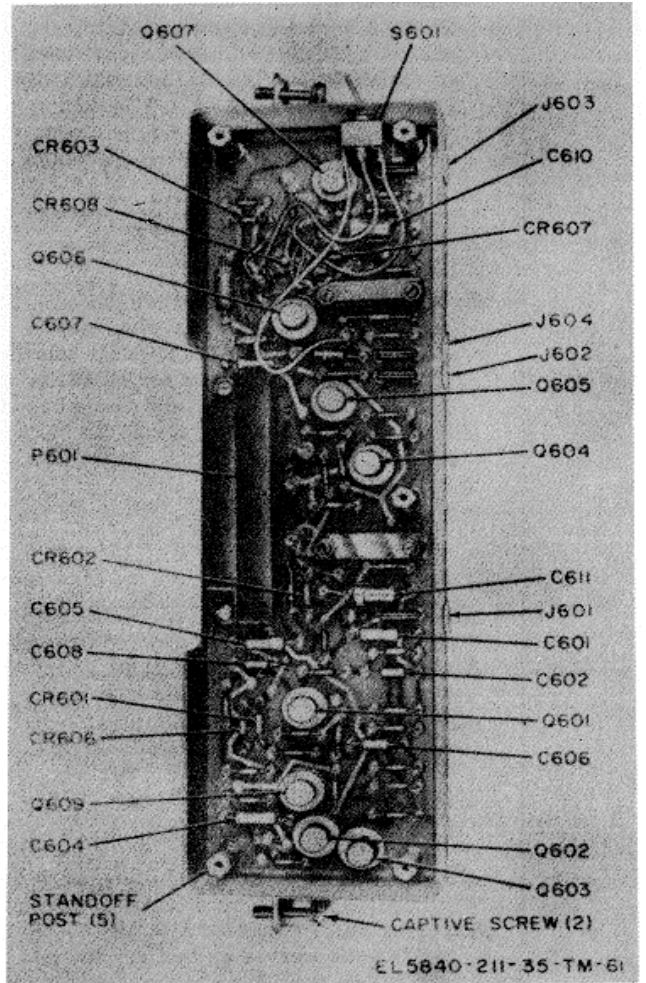

Figure 3-23. Audio unit, capacitors, diodes, transistors, and jacks.

- (b) Install the repair patch cord between plug P101 at the bottom portion of the control panel (fig. 3-31) and jack J101 at the bottom rear of the center section (fig. 3-13).

f. Afc System Troubleshooting Chart.

Item No.	Trouble symptom	Probable trouble; checks; and corrective measures
1	<p>Note. Whenever components are replaced in the, afc system, the afc sweep adjustment, klystron and magnetron tuning adjustments, testing procedures for the afc system, and range calibration adjustment procedures must be performed.</p> <p>Voltage between jack J604 on the audio unit (fig. 3-58) and ground does not measure -70 to -146 volts with the POWER switch at TRANSMIT and the AFC/MFC switch S601 (on the audio unit) at 'MFC.</p>	<ul style="list-style-type: none"> a. Potentiometer R632 in audio unit out of adjustment. Adjust potentiometer R632 in audio unit to obtain normal indication. b. Defective power converter system. Check for -150 volts at test point E601 in the audio unit (fig. 3-26). If not present, refer to the power converter system troubleshooting chart (para 3-4). c. Defective afc search and control circuit in audio unit. Refer the entire receiver-transmitter to higher category of maintenance.

Item No.	Trouble symptom	Probable trouble; checks; and corrective measures
2	<p>Voltage does not oscillate between -70 and -145 volts at approximately 5 Hz. at jack J604 on the audio unit with the POWER switch at STANDBY, the AFC/MFC switch S601 on the audio unit at AFC, and the multimeter connector between jack J604 and ground.</p> <p><i>Note.</i> For the following check, remove the cover from the directional coupler J908 access hole and remove the directional coupler cap (fig. 3-63). Place the pickup horn of the spectrum analyzer over the directional coupler access hole.</p>	<p>Defective afc search and control circuit in the audio unit. Refer to item 1c above.</p>
3	<p>Lock-on (klystron spectrum stops sweeping) does not occur when the magnetron frequency is 30 MHz below klystron frequency with the POWER switch at TRANS.MIT and the AFC/M.NFC switch S601 (on the audio unit) at AFC,</p> <p><i>Note.</i> For the following check connect oscilloscope between jack J603 on the audio unit and ground, using tip jack plug at jack J603.</p>	<p>Klystron local oscillator V902, afc attenuator and inductor L707, and potentiometer R632 out of alignment or adjustment. If lock-on does not occur proceed to items 4 and 5 below. If lock-on does occur farther away than +0.5 MHz from 30 MHz, adjust the afc attenuator (para 3-38). If the afc attenuator is near either extreme of its positions, also adjust L707 (para 3-38) in the afc unit. If lock-on occurs with the klystron frequency 35 MHz below the magnetron frequency, adjust potentiometer R632 (para 3-41).</p>
4	<p>Afc error pulse (waveform A, fig. 3-2) not observed on oscilloscope at jack J603 on the audio unit (fig. 3-58) with the POWER SWITCH AT TRAKNSMIT and the AFC, MIFC switch S601, on the audio unit, at MFC.</p> <p><i>Note.</i> For the following check, connect the oscilloscope between jack J701 on the afc unit and ground, using tip plug at jack J603.</p>	<p>Klystron local oscillator V902, magnetron V901 frequency out-of-adjustment and potentiometer R632 improperly tuned or improperly adjusted. Perform the afc sweep adjustment R632 and klystron V902 and magnetron V901 tuning adjustments (para 3-4-1).</p>
5	<p>Afc error pulse (waveform B, fig. 3-27) not observed on oscilloscope at J701 on the afc unit (fig. 3-59) with the POWER switch at TRANSMIT and the AFC/MFC switch S601 (on the audio unit) at MIFC.</p>	<ol style="list-style-type: none"> Inductor L707 improperly tuned. Perform afc unit tuning adjustment (para 3-40b(1) through (9)). Pull out afc attenuator (fig. 3-1) and retune inductor L707. Defective mixer crystal CR903. Replace afc mixer crystal CR903 and check the afc crystal current (para 3-19 above). Replace crystal if necessary. Low power output from magnetron V901. Check the power output from magnetron V901 (para 3-17). If the output is less than 27 to 33 dbm, replace and retune the magnetron (paras 3-66 and 3-41). Defective cable between the afc unit and the hybrid waveguide assembly no. 2 (fig. 3-1). Check continuity in the cable between afc unit and hybrid waveguide assembly No. 2 (fig. 3-1). Defective afc unit. Refer the entire receiver transmitter to higher category of maintenance.

3-21. Ranging System Troubleshooting

a. *Controls and Adjustments.* The following chart lists the controls and adjustments that are functional parts of the ranging system:

NOTE

When troubleshooting the ranging system with the oscilloscope, random noise

grass) will not be visible on the oscilloscope when a target is being gated. Therefore, in order to get an indication of random noise on the oscilloscope, vary the RANGE CONTROL handwheel until no target is being gated by the range gate. If noise is still not visible, adjust the VOLUME control clockwise.

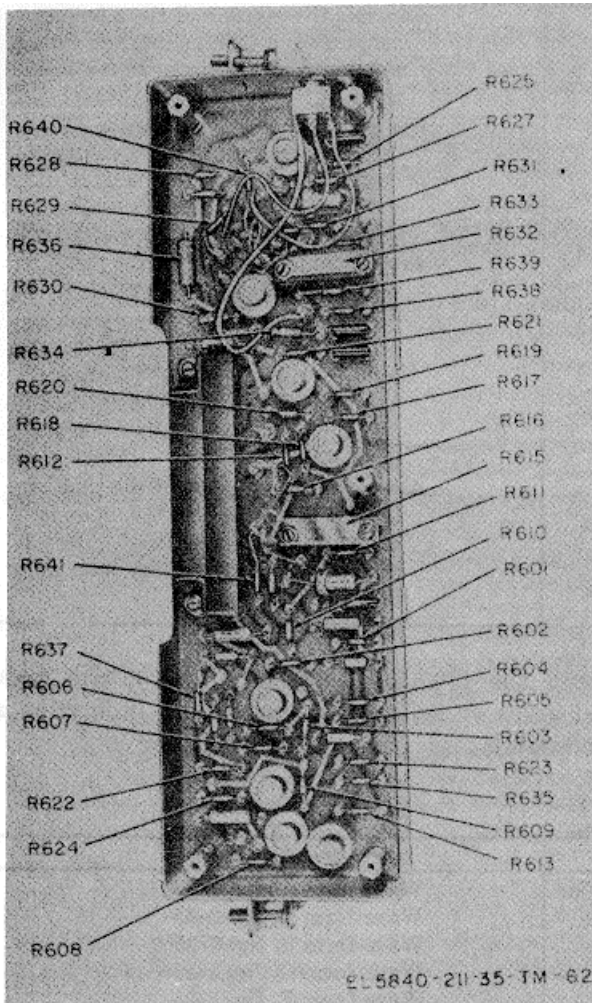

Figure 3-24. Audio unit, resistors.

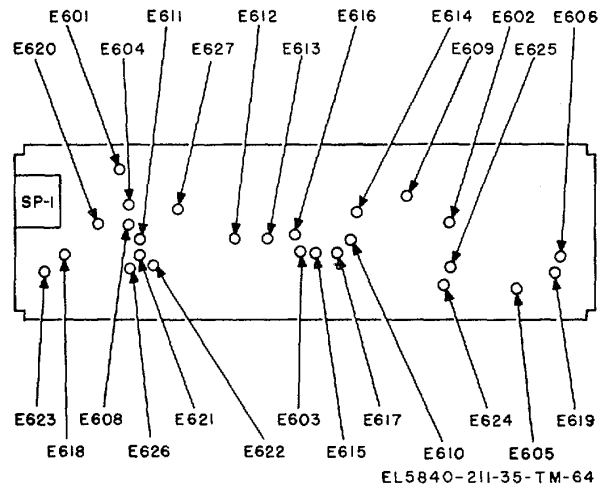

Figure 3-26. Audio unit, location of internal test points

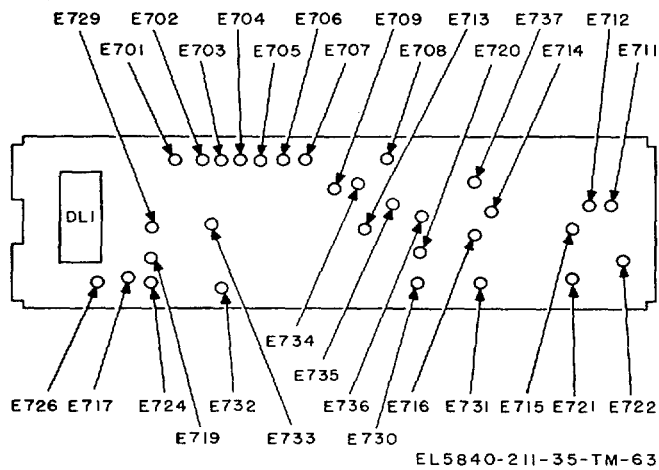

Figure 3-25. Afc unit, location of internal test points

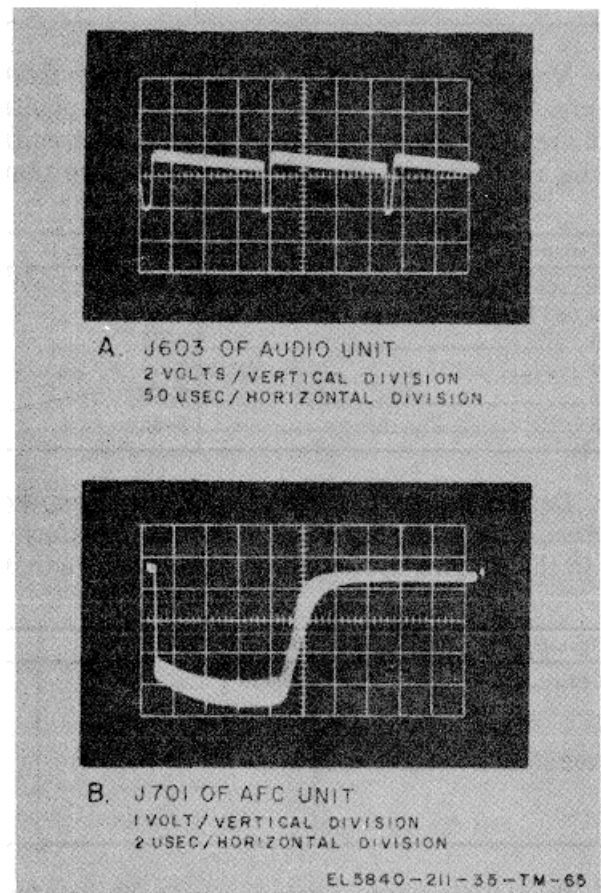

Figure 3-27. Afc system error pulse.

Controls and adjustments	Location (fig. no.)	Function
RANGE CONTROL hand wheel.....	TMI 11-58340-211-12	Controls the location of the 30-meter range gate by controlling the voltage at which pickoff diode CR4111 will conduct.
STROBE switch S105	3-31	Controls the mode of operation of the radar set by selecting the voltage to be coupled into the comparator circuit (one of two different sweeps or a reference voltage).
R1025.....	3-34	Allows the adjustment of the meter zero of the RANGE EXTENSION METERS meter by varying the dc level of the meter input.
R1017	3-34	Allows the adjustment of the strobe amplitude by varying the ratio of resistance in the voltage divider of the circuit.
R1004.....	3-34	Allows the adjustment of the time of the strobe by varying the amount of resistance in the charging circuit of capacitor C1003 which determines the rc time constant.

b. *Normal Indications at Ranging System Test Points.* The following chart lists the test points that are provided to test the operation of circuits in the

ranging system, references a figure that shows the physical location of each test point, and gives or references the normal indication at each point:

Test point	Location (fig. no.)	Normal indication
J41.....	3-5	Wave form A, fig. 3-35
J402 (STROBE switch at LONG)	3-55	Wave form B, fig. 3-35
J403	3-55	Wave form C, fig. 3-35
J404	3-55	Wave form D, fig. 3-35
J405	3-55	Wave form E, fig. 3-35
J406	3-5	Wave form F, fig. 3-35

c. *Dc Resistance of Transformers in Ranging System.* The following chart lists the transformers in the ranging system, references a figure that shows the

location of each, and gives the dc resistance of every winding:

Transformer	Location (fig. no.)	Terminals	Dc resistance (ohms)
T401	3-33	1-2	Less than 1
		3-4	Less than 1
		5-6	Less than 1
T402	3-33	1-2	Less than 1
		3-6	Less than 1
		5-6	Less than 1

d. *Preparation of System Components for Troubleshooting.*

(1) The ranging system is composed of the range unit and portions of the strobe unit. The range unit is located on the rear side of the center section of the receiver-transmitter (fig. 3-9). The strobe unit is located on the rear section (control panel of the receiver-transmitter (fig. 38). The procedures necessary to

prepare the 3-34 range and strobe units for troubleshooting are listed below.

WARNING

Before following the procedures below, check that the POWER switch is in the OFF position.

CAUTION

Care should be taken in handling the

- (d) Remove the five binding head screws that fasten the cover on the range unit, and remove the cover.

NOTE

The cover need not be removed to gain access to the test jacks.

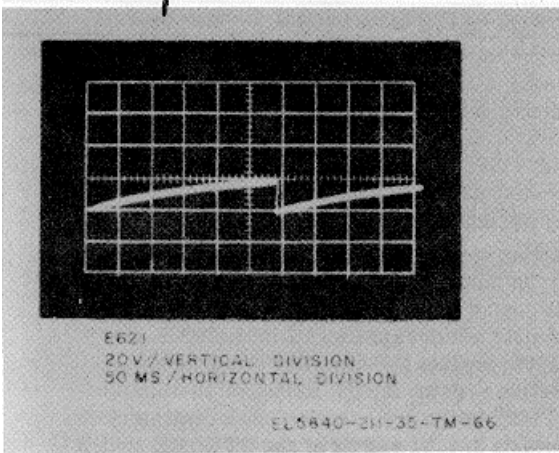

Figure 3-28. Afc sweep voltage control panel to prevent damage to meter M101, the strobe unit, and exposed soldered connections.

(2) To make the range and strobe units accessible for troubleshooting or alignment, proceed as follows:

(a) Release the four trunk-type latches that fasten the control panel on the receiver-transmitter, remove the control panel, and place it in the support fixture.

(b) Connect the repair patch cord between plug P101 on the control panel (fig. 3-8) and jack J101 on the rear of the receiver-transmitter center section (fig. 3-9).

(c) Remove the range unit from the center section (para 3-62). Connect the range bench test cable between plug P401 on the range unit and jack 401 on the center section mounting plate.

(d) Remove the five binding head screws that fasten the cover on the range unit, and remove the cover.

NOTE

The cover need not be removed to gain access to the test jacks.

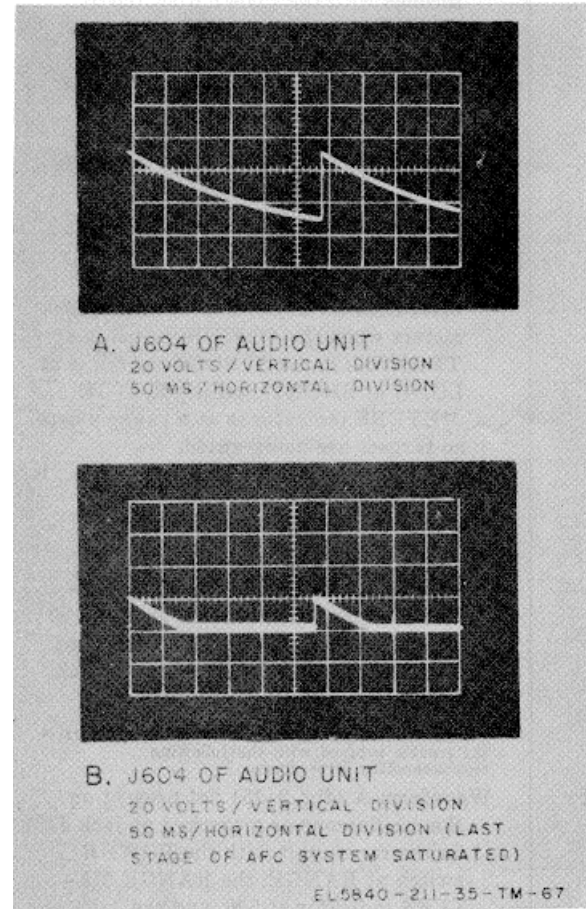

Figure 3-29. Amplified afc sweep voltage

Item	Trouble symptom	Probable trouble; checks; and corrective measures
1	No indication on RANGE EXTENSION METERS meter -MI01 when the POWER switch is at TRANSMIT, the RANGE METERS indicator is at 8,000, the STROBE switch is at OFF, and the VOLUME control R105 is rotated fully clockwise.	<p>a. Defective Zener diode CR1003 in strobe unit. Check CR1003 replace if defective.</p> <p>b. Defective meter M'101 circuit in strobe unit. Check meter circuit resistors R1015 and R1014 in the strobe unit; replace if defective.</p> <p>c. Defective age system. Refer to age system troubleshooting chart (para 3-23).</p>
2	As the RANGE CONTROL handwheel is varied from 1 to 7,5-00 meters, the needle on the RANGE EXTENSION METERS meter does not deflect to a minimum value near 500 meters and at approximately every 1,000 meters thereafter, with the POWER switch at	<p>a. Defective age system. Set the RANGE METERS indicator at 4,000. Check the output at jack J405 on the range unit (fig. 3-55). The output should be a waveform similar to E, figure 3-35. If this output is correct, refer to the age system troubleshooting chart (para 3-23).</p> <p>b. Defective strobe circuit. Remove and replace the</p>

Item	Trouble symptom	Probable trouble; checks: and corrective measures
3	<p>RANGE, the STROBE switch at OFF, and the VOLUME control R1105 rotated completely clockwise.</p> <p>Period of long strobe is not 10 ± 2 seconds with the POWER switch at TRANSMIT, the STROBE switch at LONG, and the RANGE METERS indicator at a range where no targets are being gated.</p>	<p>strobe unit (para 3-30) and refer the defective strobe unit to higher category of maintenance.</p> <p>c. Defective detector circuit, range gate circuit, comparator circuit, or linear sweep circuit. Remove and replace the range unit (para 3-62) and refer the defective range unit to higher category of maintenance.</p> <p>a. Defective capacitors C1001, C1003, or C1004 in the strobe unit. Perform the strobe period and amplitude adjustment (para 3-45). If the symptom persists, check capacitors C1001, C1003, and C1004; replace the defective components.</p> <p>b. Defective resistor R1004, R1022, or thermister RT1002 in the strobe unit. Check continuity to contacts 3, 4, 11 and 1'2 of the STROBE switch 9105. Check resistors R1004, and R1022 and thermister RT1002. Replace the defective components.</p>
4	<p>Needle on the RANGE EXTENSION METERS meter does not strobe to 500 meters when the POWER switch is at TRANSMIT, the STROBE switch is at LONG or SHORT, and the RANGE METERS indicator is at a range where no targets are being gated.</p>	<p>a. Potentiometers R1017 and R10125 in the strobe unit out-of-adjustment. Perform the strobe amplitude adjustment (para 3-4.5). Check the voltage at the junction of resistor R1012 and potentiometer R1017. If the voltage at this point is not 12 to 18 volts, adjust potentiometers R1017 and R1012.</p> <p>b. Defective Zener diode CR1001 or diode CR1002 in the strobe unit. If the measurement in the preceding step is 12 to 18 volts, check Zener diode CR1001; check four-layer diode CR1002 (para 3-10); remove and replace if defective.</p>
5	<p>Needle on RANGE EXTENSION METERS meter does not start at 0-10+50 meters when the POWER switch is at TRANSMIT and the STROBE switch is at SHORT.</p>	<p>Defective resistor R1007 or potentiometer R1025 in the strobe unit. Perform the RANGE EXTENSION METERS meter zero adjustment (para 3-27). Check resistor R1007 and continuity from R1007 to capacitor C1003; replace defective components.</p>
<p><i>Note.</i> If items 1 through 5 above do not correct the trouble proceed with the following troubleshooting procedures.</p>		
6	<p>Waveform -A (fig. 3-35) not present on the oscilloscope as measured at jack J401 on the range unit with the POWER switch at RANGE, the RANGE METERS indicator at 500, and the STROBE switch at OFF.</p>	<p>a. Multiar pulse not present at jack J408 on the range unit. Check for the multiar pulse at jack J408 (fig. 3-38). If not present, check at test point E407 for presence of a multiar pulse of approximately 15 volts in amplitude. If present, check transformer T401. If transformer T401 is defective, remove and replace the range unit and refer the defective range unit to higher category of maintenance.</p> <p>b. Defective cable between J408 on the range unit and P207 on the transmitter unit. Check for continuity of the interconnecting cable; replace if necessary.</p> <p>c. Defective transmitting system. Refer to transmitting system troubleshooting chart (para 3-17).</p>
7	<p>Waveform (B, fig. 3-35) not observed on the oscilloscope at jack J402 on the range unit with the POWER switch at RANGE, the RANGE METERS indicator at 500, and the STROBE switch</p>	<p>a. Faulty connections to strobe unit. Check connections to strobe unit.</p> <p>h. Defective strobe unit. Remove and replace the strobe unit (para 3-60). Refer the defective strobe unit to higher category of maintenance.</p>
8	<p>Dc voltage of 3.75 is not measured at jack J406 on the range unit with the POWER switch at RANGE, the RANGE METERS indicators at 500, and the STROBE switch at OFF.</p>	<p>a. Faulty connections between the control panel and the range unit. Check the connections between the control panel and the range unit.</p> <p>b. Positive 60 volts dc not present at test point E422 on the range unit (fig. 3-36). Check for +60 volts dc at test point E422.</p>

Item	Trouble symptom	Probable trouble; checks: and corrective measures
9	Waveform (C, fig. 3-35) not observed on the oscilloscope at jack J403 on the range unit with the POWER switch at TRANSMIT, the RANGE METERS indicator at a range where no targets will be gated, and the STROBE switch at OFF.	<ul style="list-style-type: none"> c. Defective diodes CR405 and CR417. Remove and replace the range unit (para 3-62) and refer the defective unit to higher category of maintenance. a. Faulty cable or connections between the receiving system and the range unit. Check the interconnecting cabling. b. Defective receiving system. Refer to receiving system troubleshooting chart (para 3-19).
10	Waveform (1, fig. 3-35) not observed on the oscilloscope at jack J404 on the range unit with the POWER switch at TRANSMIT, the RANGE -METERS indicator at a range where no targets will be gated, and the STROBE switch at OFF. Waveform observed is similar to A, fig. 3-37.	<ul style="list-style-type: none"> a. Negative 2.2 volts not present at jack J402 on the range unit. Check the connection between the strobe unit and the range unit. b. Voltage from 20 to 30 volts not present at jack J406 on the range unit. Check the connection between the control panel and the range unit. c. Positive 60 volts not present at test point E422 in the range unit. Check diodes C'R40,5 and CR417 in range unit; if defective, remove and replace the range unit (para 3-62) and refer the defective range unit to higher category of maintenance.
14	Waveform (D, fig. 3-3a5) not observed on the oscilloscope at jack J404 on the range unit with the POWER switch at TRANSMIT, the RANGE METERS indicator at a range where no targets will be gated, and the STROBE switch at OFF. Waveform observed is similar to B, fig. 3-37.	<ul style="list-style-type: none"> a. No video input at jack J403. Check at jack J403 on the range unit for video input from the IF amplifier unit. If not present, check the connections between the IF amplifier unit and the range unit. If the connection is satisfactory, remove and replace the IF amplifier unit (para 3-63) and refer the defective IF amplifier unit to higher category of maintenance. b. No video signals at jack J404. If there is no video at jack J404, check for continuity between jack J404 and test point E424. Check capacitor Cr17. If defective, remove and replace the range unit and refer the defective range unit to higher category of maintenance.
12	Waveform (E, fig. 3-35) not observed on oscilloscope at jack J405 on range unit with the POWER switch at TRANSMIT, the RANGE MIETERS indication at a range where no targets will be gated, and the STROBE switch at OFF.	Defective transistor Q406 or Q407, or defective diodes CR4'13 or CR414. Remove and replace the range unit (para 3-02) and refer the defective range unit to higher category of maintenance.

3-22. Audio System Troubleshooting

a. *Normal Indications at Audio System Test Points.*
The following chart lists the test points that are provided

in the audio system, reference a figure that shows the physical location of the test points, and references or provides the normal indications at the test points:

Test point	Location (fig. no.)	Normal indication
J601-----	3-58	Wave form A, fig. 3-41
E624 -----	3-96	Wave form B, fig. 3-41
E606-----	3-26	Wave form C, fig. 3-41
T1, pin 5-----	3-13	Wave form D or E, fig. 3-41
E603-----	3-26	-19V to -2.1V
E605-----	36	21V to 24V
E609-----	36	0.9V to 1.6V
E13-----	3-26	8V to 25.2V
E615-----	36	8V to 25.2V
E625-----	3-26	0.5V to 2.0V

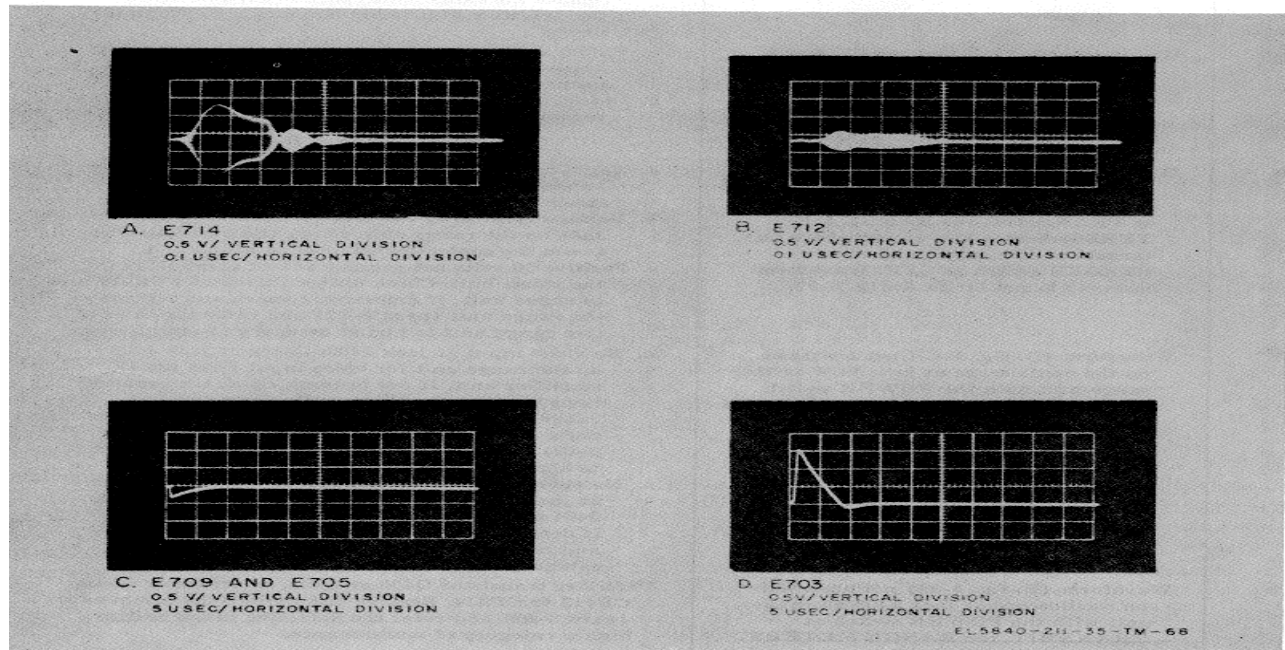

Figure 3-30. Afc unit waveforms.

b. Dc Resistance of Audio Transformer T1. The following chart gives the dc resistance of

audio transformer T1 and references a figure that show its location:

Transformer	Location (fig. No.)	Terminals	Dc resistance (ohms)
T1-----	3-13	1-5 1-2	50±5 8±1

c. Preparation of System Components for Troubleshooting.

(1) When the radar set is completely assembled, the audio unit, audio filter, audio transformer, and RF filters are inaccessible for troubleshooting, aligning, and field testing. To make these components accessible, follow

the procedure given below when troubleshooting, aligning, and/or testing the audio system.

WARNING

Before following the procedures in (2) below make sure that the POWER switch on the control panel is in the OFF position.

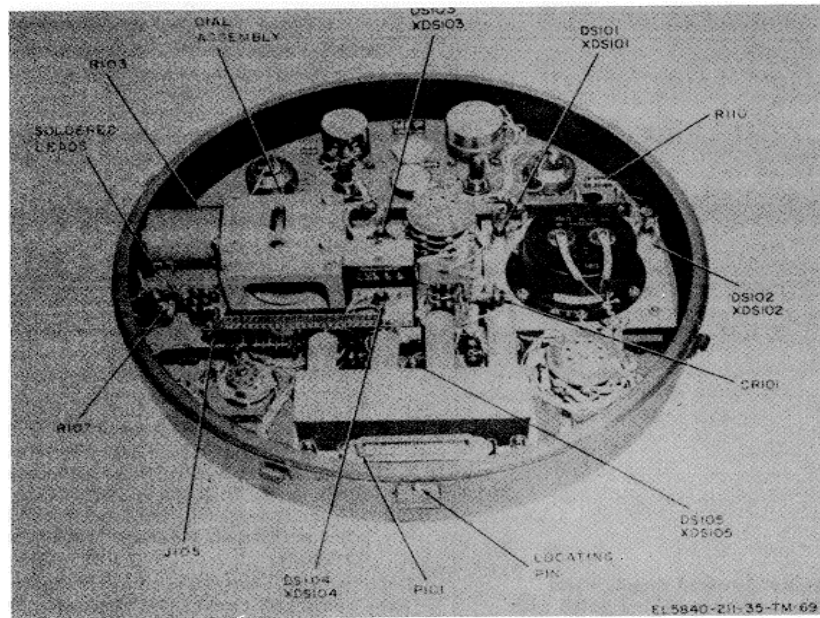

Figure 3-31. Rear of control panel, strobe unit removed.

(2) To make the audio unit, audio filter FL13, filters F'L103, and FL104, and audio transformer T1 accessible for troubleshooting, aligning, and/or testing, proceed as follows:

(a) Disconnect all cables that are connected to the receptacles on the control panel of the receiver-transmitter.

(b) Release the four trunk-type latches that secure the control panel to the receiver transmitter, remove the control panel, and place it in the support fixture.

(c) Connect the repair patch cord between jack J101 on the rear of the receiver-transmitter center section (fig. 3-13) and plug P101 on the rear of the control panel (fig. 331).

(d) Connect the power cable and the

headset cable to their respective receptacles on the control panel.

(e) When it is necessary to check the internal test points in the audio unit, follow the procedures given in the audio unit, follow the procedures given in paragraph 3-64 to remove the audio unit from the receiver-transmitter mounting plate. To remove the audio unit cover, and to connect the removed audio unit to the receiver-transmitter, follow the procedures given in (f) and (g) below.

(f) Remove the five binding head screws and five lockwashers that fasten the cover on the audio unit, and remove the cover (fig. 3-58).

(g) Connect plug P601 on the audio unit to jack J601 on the receiver-transmitter mounting plate (fig. 3-60).

d. Audio System Troubleshooting Chart.

Item	Trouble symptom	Probable trouble; checks: and corrective measures
1	Absence of rushing sound in headsets when the POWER switch is at TRANSMIT, the STROBE switch is at OFF, and the radar set is not gathering any large clutter.	<p>a. Defective receiving or age system. With the oscilloscope, check for a waveform (C, fig. 3-35) at jack J403 on range unit. If not normal troubleshoot the receiving system (para 3-19) and age system (para 843).</p> <p>b. Defective range unit. If waveform observed in above is normal, check at jack J601 on the audio unit (fig. 3-5) for random noise (grass). -If not present, troubleshoot the ranging system (para 3-21).</p>

Item	Trouble symptom	Probable trouble; checks: and corrective measures
2	Abnormally distorted sounds when moving targets are being gated with the POWER switch at TRANSMIT and the STROBE switch at OFF.	<p>c. Defective audio system. If random noise is present in <i>b</i> above, measure the noise level with the oscilloscope at pin 1, of audio transformer T1 (fig. 3-1). Amplitude of noise peaks should be 0.8 ± 0.4 volt when the VOLUME control is at extreme clockwise position. If the level of noise is incorrect, remove and replace the audio unit (para 344) and refer the defective audio unit to higher category of maintenance. If the level of noise is correct, check noise level at pin 2 of audio transformer T1. Level should be 0.2 ± 0.1 volt. If noise level is incorrect, check audio transformer T1. If defective, remove and replace the center section and refer the defective center section to higher category of maintenance.</p> <p>d. Defective headsets. Check for correct noise level at headset receptacles. If incorrect, check filters FL103 and FL104. If defective, remove and replace defective control panel. Refer the defective control panel to higher category of maintenance. If noise level is correct, check the headset using the multimeter. Resistance should be 10 ± 2 ohms and a clicking noise should be heard in headsets when multimeter leads are touched to the headset terminals.</p>
3	Normal rushing sound in headsets but moving targets cannot be detected with the POWER switch at TRANSMIT and the STROBE switch at OFF	<p>Defective audio amplifier circuit. Remove and replace the audio unit (para 3-64). Refer the defective audio unit to higher category of maintenance.</p> <p>a. Defective transmitting system. Check the magnetron power output (para 3-1-7) and replace magnetron if defective (para 367).</p> <p>b. Defective afc system out-of-adjustment. Check the afc system tuning (para 3-40).</p> <p>c. Defective receiving system. Troubleshoot the receiving system (para 3-9).</p> <p>d. Defective age system. Troubleshoot the age system (para 3-23).</p>

3-23. Automatic Gain Control System Troubleshooting

a. *Controls and Adjustments.* The following

chart lists the controls and adjustments that are functional parts of the agc system:

Controls and adjustments	Location (fig. no.)	Function
VOLUME control R106 -----	TM 11-5840-211-12	Varies dc level of output from age system when there is no gated video by varying amount of resistance in circuit of transistor Q605.
Potentiometer R615 -----	3-24	Varies age threshold bias on diode CR602 by varying amount of resistance in circuit of CR602.

b. *Normal Indications at Ago System Test Points.* The normal indication at test point (fig. 3-23) is -2.5 to -5.5 volts when the VOLUME control R105 is completely clockwise, potentiometer R615 is adjusted properly, and no signals are gated.

c. *Preparation of System Components for Troubleshooting.* The components of the age system are located in the audio unit (figs. 3-23 and 3-24). To make the audio unit accessible for troubleshooting, follow the procedures given in paragraph 3-22c

d. Age System Troubleshooting Chart.

NOTE

Normal indications on RANGE EXTENSION METERS meter are given in TM 11-5840-211-12.

Item	Trouble symptom	Probable trouble; checks: and corrective measures
1	Abnormal indication on RANGE EXTENSION -METERS meter when the POWER switch is at TRANSMIT, the STROBE switch is at OFF, and no target is being gated.	<p>a. Defective age system or strobe circuit in the ranging system. Check the dc level at jack J602 on the audio unit. The voltage should be -2.5 volts to -5.5 volts when no signal is being gated and VOLUME control is rotated completely clockwise. If voltage is correct, remove and replace the strobe unit (para 3-60) and refer the defective strobe unit to higher category of maintenance.</p> <p>b. Defective control system. If the voltage is not correct in a above, check the voltage at test point E613 (fig. 3-26) when VOLUME control is varied. The dc voltage should be approximately +8 volts (VOLUME control completely clockwise) to +24 volts (VOLUME control completely counterclockwise). If the voltage is not correct, check for +24 volts at terminal 15 of TB1. If not satisfactory, refer to the power converter troubleshooting chart (para 3-24). If satisfactory, set the POWER switch at STANDBY and check resistors R105 and R109 in the control panel. If not satisfactory, remove and replace the control panel (para 3-59). Refer defective control panel to higher category of maintenance.</p>
2	No noise in headset or noise intensity does not change as the VOLUME control is varied when POWER switch is at TRANSMIT, the STROBE switch is at OFF, and no target is being gated.	<p>a. Defective receiving system. Refer to receiving system troubleshooting chart (para 3-419).</p> <p>b. Defective ranging system. Connect the oscilloscope to jack J601 on the audio unit. If there is no random noise, troubleshoot the ranging system (para 3-21).</p> <p>c. Defective audio system. With a multimeter, check the voltage at jack J601 on the audio unit. The dc voltage should be approximately -2 volts. If the voltage is not correct, troubleshoot the ranging system (para 3-21).</p>
3	Dc voltage at jack J602 on the audio unit is not within the range of -2.6 and 45.5 volts when potentiometer R115 (threshold adjustment) is adjusted properly and VOLUME control is fully clockwise with the POWER switch at TRANSMIT, the STROBE switch at OFF, and the RANGE METERS indicator set so no targets are being gated.	Defective transistor Q605 in the audio unit. Check voltage at test point E616 (fig. 3-26). Voltage should be -20 ±2 volts. Voltage at test point E612 should be approximately 0.5 volt more negative than voltage at jack J60i2. If not correct, remove and replace the audio unit (para 3-64). Refer the defective audio unit to higher category of maintenance.
14	Dc voltage at test point E612 in the audio unit not within the range of -3 to -6 volts with controls set as in tem 3 above.	Defective transistor Q604 or diode CR602. Check the voltage at test point E610 (fig. 3-26). Voltage should be approximately -1 volt. If not correct, remove and replace the audio unit (para 3-64). Refer the defective audio unit to higher category of maintenance.
5	Dc voltage at test point E610 on the audio unit is not approximately -1 volt when potentiometer R615 is fully counterclockwise with POWER switch at TRANSMIT, STROBE switch at OFF, and RANGE METERS indicator set so no targets are being gated. higher category of maintenance.	<p>a. Defective potentiometer R61S. Check the voltage at test point E614 (fig. 3-26) and vary potentiometer R615 from fully counterclockwise to fully clockwise. Voltage should vary from +124 volts to -20 volts. If it does not, check potentiometer R61,5. If defective, remove and replace the audio unit (para 3-64). Refer defective audio unit to</p> <p>b. Defective transistor Q604 or diode CR602. Check the voltage at test point E610 (fig. 3-26) with</p>

Item	Trouble symptom	Probable trouble; checks: and corrective measures
6	<p>Dc voltage at jack J6012 on the audio unit is not within the range of -2.5 and D-5.5 volts with potentiometer R615 fully counterclockwise, the VOLUME control fully clockwise, the POWER switch at TRANSMIT the STROBE switch at OFF, and the RANGE METTERS indicator at a point ,where no targets are being gated</p>	<p>potentiometer RG15 in extreme counterclockwise position. Voltage should be approximately -1 volt. If it is not, remove and replace the audio unit and refer the defective audio unit to higher category of maintenance.</p> <p>Defective potentiometer R615. Measure voltage at jack J6f2 and rotate R615 from the fully counterclockwise position until voltage indication at J6)2 begins to change. Measure the voltage at test point E610 (fig. 3-26). Voltage at J602 as divided by voltage at E010 should be more than 3 volts. If not, remove and replace the audio unit (para 3-64). Refer the defective audio unit to higher category of maintenance.</p>

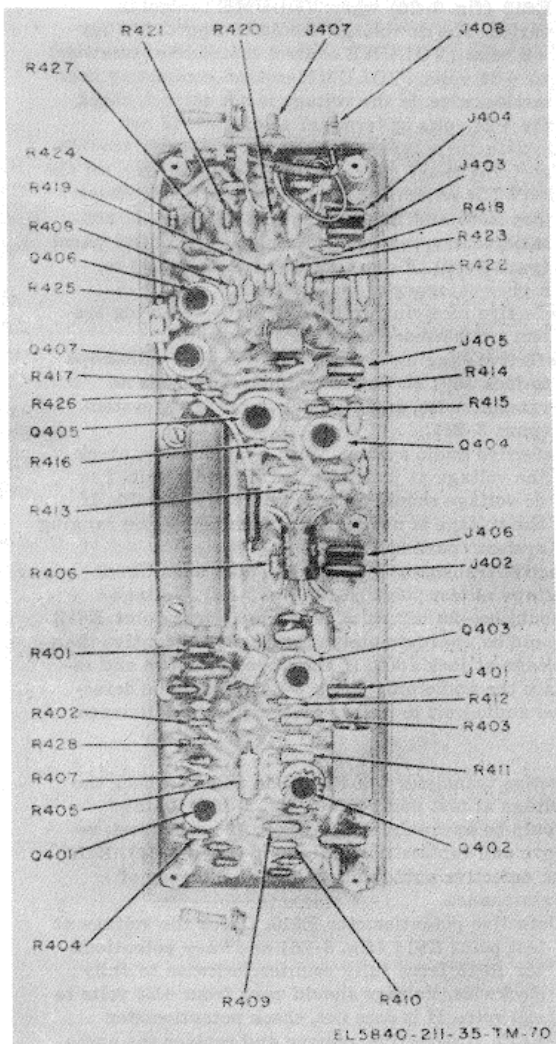

Figure 3-32. Range unit, resistors, transistors, and jacks

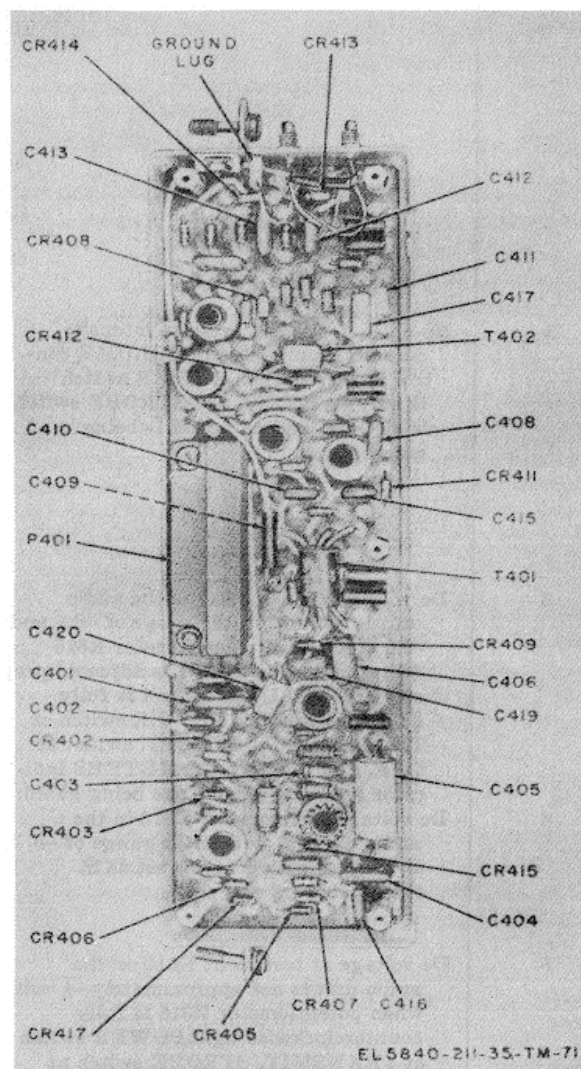

Figure 3-33. Range unit, diodes, capacitors, and transformers.

3-24. Power Converter System Troubleshooting

a. Power Converter System Controls and

Adjustments. The following chart lists the controls and adjustments that are functionally related to the power converter system:

Controls and adjustments	Location (fig. no.)	Function
POWER switch S101	TM 11-5840-211-12	Supplies the negative battery voltage to multivibrators Q801 and Q802 when the switch is in any position except OFF.
VOLTAGE ADJ. switch S102	TM 11-5840-211-12	Determines the primary to secondary turns ratio of power transformer T801, and thereby controls the voltage output of the power converter system.
Interlock switch S1	3-1	Disconnects the +24-volt input from the receiver transmitter when the radome is removed from the receiver-transmitter.
Battery test switch S104	TM 11-5840-211-12	When depressed, permits the monitoring of the +24-volt line from the power converter system.

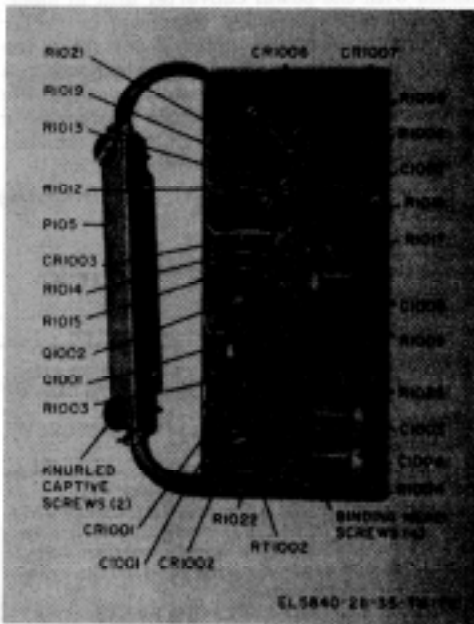

Figure 3-34. Strobe unite.

b. Power Converter System Fuse. POWER FUSE F102 (TM 11-5840-211-12) has a rating of 2 amperes and 250 volts. If an overload occurs in the power converter system, this fuse blows to prevent excessive current drain from the external power source.

c. Normal Panel Meter Indication for Power Converter System. RANGE EXTENSION METERS meter M101, when used in conjunction with the BATTERY TEST switch, monitors the +24-volt output of the power converter system. If the meter is properly calibrated, the needle of the meter indicates midscale when the +270-volt supply output is set to +270 volts by adjusting the input voltage.

d. Dc Resistance of Transformers in Power Converter System. The following chart lists the transformers in the power converter system, references figures which show the physical position of each transformer, and gives the dc resistance of each winding.

NOTE

Resistance values given for transformers T801 and T802 are applicable only when the transformers are disconnected from the power converter system circuits.

Transformer	Location (fig. no.)	Terminals	Maximum dc resistance (ohms)
T801 primary	3-42	1-15	0.5
T801 secondary	3-42	16-27	556
		16-18	50
		18-20	15
		20-22	5
		22-24	16
		24-26	60
		28-29	1
		3031	1
		3233	0.5
T802 primary	3-42	1-2	16
T802 secondary	3-42	3-5	2
		4-5	1

e. Preparation of Power Converter System Components for Troubleshooting.

(1) *General.* The power converter system is located on the front side of the center section of the receiver-transmitter (fig. 3-1). The procedures necessary to prepare the power converter system for troubleshooting are listed in (2) and (3) below.

(2) *Power converter unit access.* To make the power converter unit accessible for troubleshooting, proceed as follows:

(a) Set the POWER switch at OFF.

(b) Release the four trunk-type latches on the front section (radome) of the receiver transmitter and remove the radome.

CAUTION

Care should be taken to prevent damage to the parabolic reflector and to the antenna feed assembly.

(c) Remove the four No. 632 x 3/8 binding head screws that fasten the cover on the power converter unit, and remove the cover.

(d) Pull interlock switch S1 (fig. 3-1) to the full forward position in order to disable the interlock and connect the external power source to the power converter system.

(e) Connect the variable power supply to 24VDC BAT. ONLY receptacle J104 on the control panel (positive lead to pin A, negative lead to pin B). Set the variable power supply for an output voltage of 24 volts.

(f) Set the POWER switch at STANDBY.

(3) *Power converter unit troubleshooting setup.* Most troubleshooting can be accomplished with the power converter unit in place. However, when necessary, the power converter unit can be removed (para 3-66) from the receiver-transmitter. When troubleshooting a removed power converter unit, connect the power converter bench test cable between plug P801 on the power converter unit and jack J801 on the receiver-transmitter center section.

f. Power Converter System Troubleshooting Chart.

WARNING

Extremely dangerous voltages exist in the power converter system. Set POWER switch S101 at OFF before attempting to check any components.

Item	Trouble symptom	Probable trouble; checks: and corrective measures
1	RANGE EXTENSION METERS meter M101 indicates zero when the BATTERY TEST switch S104 is depressed and the POWER switch is in position but OFF. No noise heard in headsets when the POWER switch is in the TRANSMIT position.	<ul style="list-style-type: none"> a. Blown POWER FUSE F102. Check POWER FUSE F102 and replace if necessary. Check for 24-volt output of external power source. b. Faulty receptacle J104. Check 24 VDC BAT. ONLY receptacle J104 for proper contact. c. Faulty interlock switch S1. Check interlocks switch S1 for proper operation (para 3-25). d. Faulty VOLTAGE ADJ switch S102. Check VOLTAGE ADJ switch for continuity. If defective, remove and replace the control panel (para 3-59). Refer the defective control panel to higher category of maintenance. e. Faulty BATTERY TEST switch S104. Check BATTERY TEST switch for proper operation. If defective, remove and replace the control panel (para 3-59). Refer the defective control panel to higher category of maintenance. f. Incorrect voltage outputs. Measure output voltages (para 3-4) with POWER switch at TRANSMIT. If all voltages are low or zero, check for proper contact of plug P801. Check resistors R801, R802, R805 and R809 for signs of overheating or change in value. If defective, remove and replace the power converter unit (para 3-66). Refer the defective unit to higher category of maintenance.

Change 2 3-44

Item	Trouble symptom	Probable trouble; checks: and corrective measures
2	POWER FUSE F102 continues to blow	<p>cable; if defective, remove and repair (para 3-54)</p> <p>b. Defective switch S101 or S102. Check continuity of switches S101 and S102. If defective, remove and replace the control panel (para 3-69). Refer defective control panel to higher category of maintenance.</p> <p>c. Overload or short circuit within the radar set. Remove and replace the power converter unit (para 3-66). Refer the defective power converter to higher category of maintenance.</p>
3	RANGE EXTENSION METERS meter indicates below red zone when BATTERY TEST switch is depressed, and POWER switch is not in OFF position.	<p>a. Maladjustment of BOLTAGE ADJ switch S102. Advance VOLTAGE ADJ switch to a higher number, checking each position by depressing BATTERY TEST switch. If each position fails to produce a higher voltage, remove and replace the control panel. Refer the defective control panel to higher category of maintenance.</p> <p>b. Deficient external power source. If position 7 fails to produce a proper voltage, adjust external power source. If a battery is used as power source, replace battery.</p> <p>c. Defective meter circuit. Refer to troubleshooting based on starting procedure (para 3-16).</p>
4	RANGE EXTENSION METERS meter indicates above red zone when the BATTERY TEST switch is depressed.	<p>a. Maladjustment of VOLTAGE ADJ. switch S102. Turn the VOLTAGE ADJ. switch to a lower number until a proper voltage is indicated.</p> <p>b. Shorted primary of transformer T801. Place POWER switch at OFF and perform a resistance measurement of T801 primary winding. If defective, remove and replace the power converter unit (para 3-66). Refer defective power converter unit to higher category of maintenance.</p> <p>c. Defective meter circuit. Refer to troubleshooting based on starting procedure (para 3-16).</p> <p>d. Meter improperly calibrated. Refer to para 4-20.</p>
5	Positive 270 volts not present at terminal 4 of TB1 (fig. 3-2) with the POWER switch at TRANSMIT.	<p>a. Capacitor C807 open. Check capacitor C807 and leads for opens. If defective, remove and replace the power converter unit (para 3-66). Refer the defective power converter to higher category of maintenance.</p> <p>b. Defective diode CR809 or CR810. Check CR809 and CR810. If defective, remove and replace the power converter unit (para 3-66). Refer the defective power converter to higher category of maintenance.</p> <p>c. Defective capacitor C6 (fig. 3-1). Check capacitor C6 in the receiver-transmitter center section. If defective, remove and replace the center section. Refer the defective center section to higher category of maintenance.</p> <p>d. Defective reactor L1 (fig. 3-1). Check reactor L1 in the receiver-transmitter center section. If defective, remove and replace the center section. Refer the defective center section to higher category of maintenance.</p> <p>e. Variable power supply output incorrect. Adjust the variable power supply until normal indication is observed.</p>
6	Negative 145 to -158.3 volts not measured at terminal 10 of TB1 (fig. 3-13) with the POWER switch at TRANSMIT.	<p>a. Defective capacitors C805, C806 and leads. Check capacitors C805, and leads for opens. If defective, remove and replace the power converter unit (para 3-66). Refer the defective power converter unit to higher category of maintenance.</p>

Item	Trouble symptom	Probable trouble; checks: and corrective measures
7	Positive 120 \pm 6 volts not measured at terminal 5 of TB1 (fig. 3-13) with the POWER switch at TRANSMIT.	<p><i>b.</i> Defective diodes CR807 and CR808. Check diodes CR807 and CR 808. If defective, remove and replace the power converter unit (para 3-66). Refer the defective power converter unit to higher category of maintenance.</p> <p><i>a.</i> Defective capacitor C804. Check capacitor C804 and leads for opens. If defective, remove and replace the power converter unit (para 3-66). Refer the defective power converter to higher category of maintenance.</p>
8	Positive 24 +1.2 volts not measured at terminal 6 of TB1 (fig. 3-13) with the POWER switch at TRANSMIT.	<p><i>b.</i> Defective diodes CR805 or CR806. Check diodes CR805 and CR806. If defective, remove and replace the power converter unit (para 3-66). Refer the defective power converter to higher category of maintenance.</p> <p><i>a.</i> Defective capacitor C802. Check capacitor C802 and leads for opens. If defective, remove and replace the power converter unit (para 3-66). Refer the defective power converter to higher category of maintenance.</p>
9	Negative 20 +1 volts not measured at terminal 9 of TB1 (fig. 3-13) with the POWER switch at TRANSMIT.	<p><i>b.</i> Defective diodes CR803 and CR804. Check diodes CR803 and CR804. If defective, remove and replace the power converter unit (para 3-66). Refer the defective power converter to higher category of maintenance.</p> <p><i>a.</i> Defective capacitor C801. Check capacitor C801 and leads for opens. If defective, remove and replace the power converter unit (pars 3-66). Refer the defective power converter unit to higher category of maintenance.</p>
10	Measured ripple voltage exceeds 0.3 peak-to-peak as observed on the oscilloscope when connected between terminal 4 of TB1 (fig. 3-13) and ground with the POWER switch at TRANSMIT after a delay of 90 seconds.	<p><i>b.</i> Defective diodes CR801 and CR802. Check diodes CR801 and CR802. If defective, remove and replace the power converter unit (para 3-66). Refer the defective power converter unit to higher category of maintenance.</p> <p>Same as item 5.</p>
11	Measured ripple voltage exceed 0.4 peak-to-peak as observed on the oscilloscope when connected between terminal 10 of TB1 (fig. 3-13) and ground with the POWER switch at TRANSMIT after a delay of 90 seconds.	Same as item 6 a.
12	Measured ripple voltage exceeds 1.5 peak-to-peak as observed on the oscilloscope when connected between terminal 5 of TB1 (fig. 3-13) and ground with the POWER switch at TRANSMIT after a delay of 90 seconds.	Same as item 7 a.
13	Measured ripple voltage exceeds 0.4 peak to peak as observed on the oscilloscope when connected between terminal 6 of TB1 (fig. 3-13) and ground with the POWER switch at TRANSMIT after a delay of 90 seconds.	Same as item 8 a.
14	Measured ripple voltage exceeds 0.4 peak-to-peak as observed on the oscilloscope when connected between terminal 9 of TB1 fig. (3-13) and ground with the POWER switch at TRANSMIT and after a delay of 90 seconds.	Same as item 9 a.

Item	Trouble symptom	Probable trouble; checks: and corrective measures
15	With the oscilloscope connected between terminals 11 and 12 of TB1 (fig. 3-13), 6.11 to 6.62 volts rms not observed with the POWER switch at TRANSMIT after a delay of 90 seconds.	Defective secondary of transformer T801. Check secondary of transformer T801 for shorts. If defective, remove and replace the power converter unit (para 3-66). Refer the defective power converter to higher category of maintenance.
16	With the oscilloscope connected across terminals 13 and 14 of TB1 (fig. 3-13), 6.65 to 7.35 volts rms not observed on the oscilloscope with the POWER switch at TRANSMIT after a delay of 90 seconds.	Same as item 15.
17	With the multimeter connected across contact 5 of switch S106 and ground, 2.43 to 2.97 volts rms not measured with the POWER switch at TRANSMIT after a delay of 90 seconds.	Same as item 15.

3-25. Operational Check of Interlock Switch S1

WARNING

Power must be applied to the radar set to check the operation of the interlock switch. Since the interlock switch functions to protect personnel from voltages in excess of 500 volts, the warning procedures in paragraph 3-7 shall be reviewed before proceeding with the operation check below.

- a. Set the POWER switch to OFF.
- b. Remove the radome (para 3-59)
- c. Set the POWER switch to TRANSMIT, the STROBE switch to OFF, and the VOLUME ADJ switch to position 1, and depress the BATTERY

- d. TEST button and hold for a delay of 90 seconds.
- d. Push interlock switch to the full rearward position and observe the RANGE EXTENSION METERS meter needle.
 - (1) Meter needle should indicate in the center of the red zone. If it does not, pull switch S1 to the full forward position, remove power, discharge capacitor C6, and check interlock switch continuity. If defective, remove and replace the center section and refer the defective center section to higher category of maintenance.
 - (2) If meter needle indicates anywhere but in the center of the red zone and the continuity check proves satisfactory, switch S1 is functioning properly and a malfunction exists elsewhere in the radar set.

Change 1 3-47

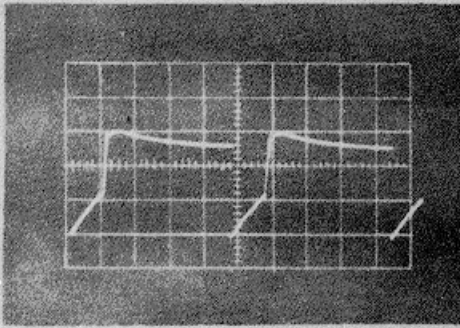

A. J401
10 V / VERTICAL DIVISION
50 USEC / HORIZONTAL DIVISION

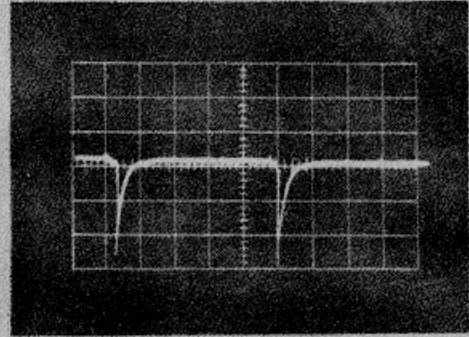

B. J402
1 V / VERTICAL DIVISION
50 USEC / HORIZONTAL DIVISION

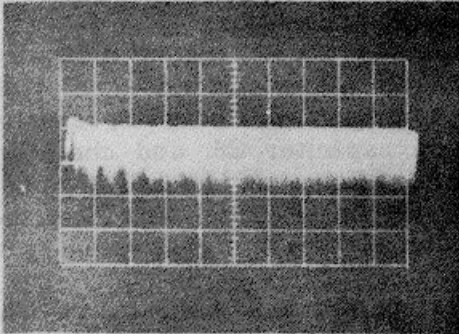

C. J403
0.5 V / VERTICAL DIVISION
5 USEC / HORIZONTAL DIVISION

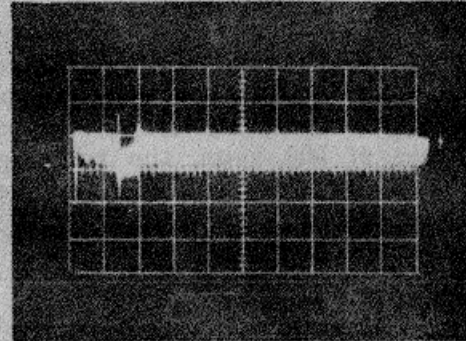

D. J404
1 V / VERTICAL DIVISION
10 USEC / HORIZONTAL DIVISION

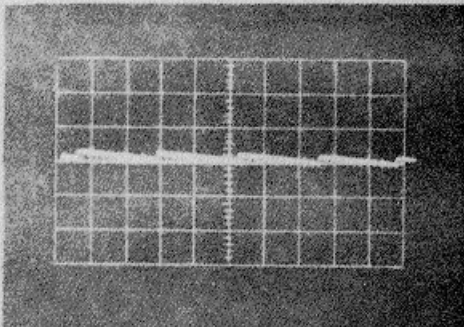

E. J405
0.5 V / VERTICAL DIVISION
100 USEC / HORIZONTAL DIVISION

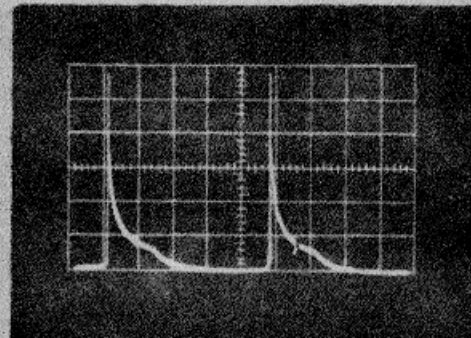

F. J406
2 V / VERTICAL DIVISION
50 USEC / HORIZONTAL DIVISION

EL5840-211-35-TM-73

Figure 3-35. Normal indications at ranging system test jacks

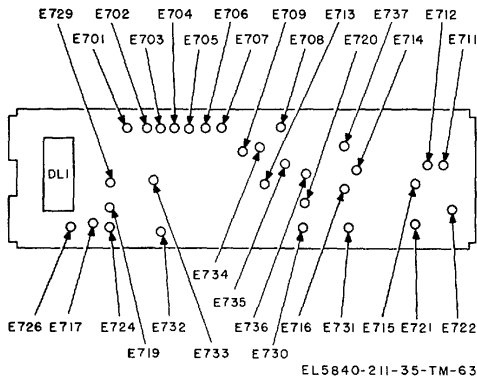

Range unit, location of internal test points

EL5840-211-35-TM-63

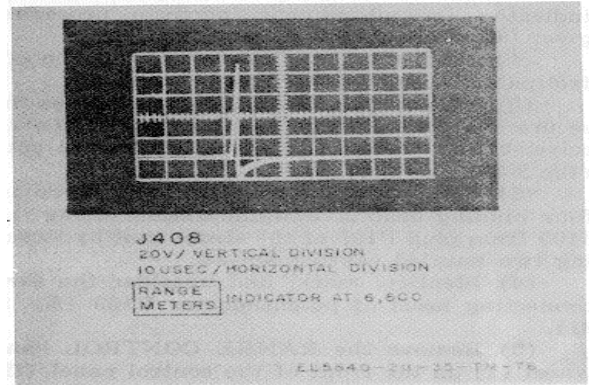
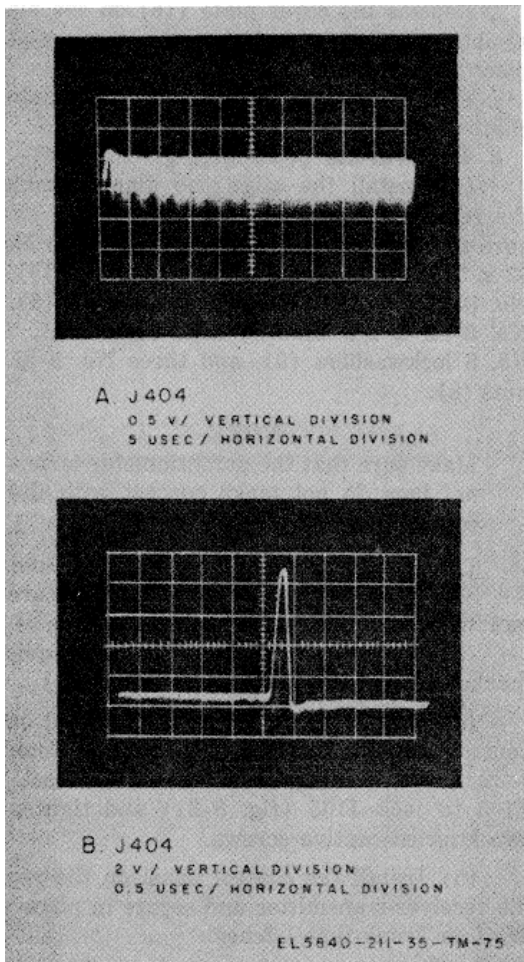

Figure 3-36.

Figure 3-38. Multiar pulse.



Abnormal indications at range unit jack J4.

Figure 3-37.

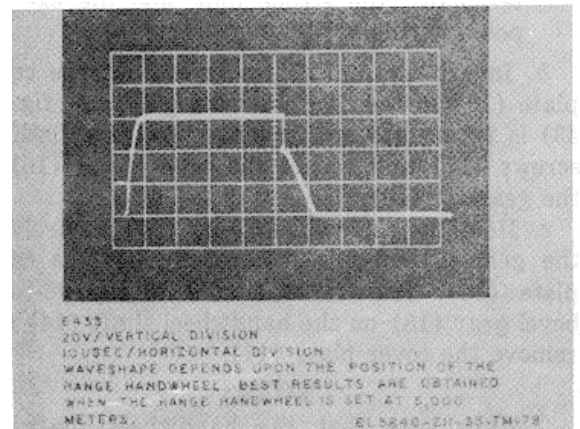

Figure 3-39. Sweep at E415.

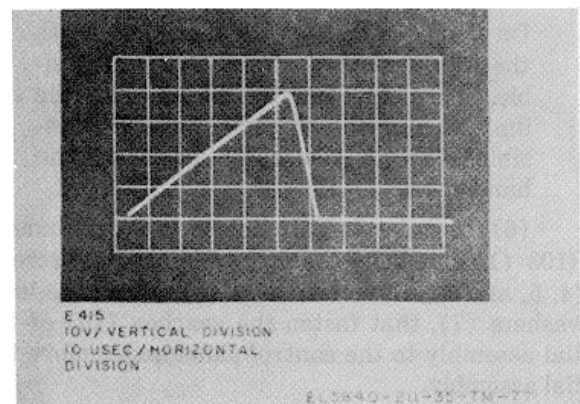

Figure 3-40. Square wave at E433.

a. In order to prepare the RANGE METERS indicator for adjustment, perform procedures given below.

(1) Place the POWER switch on the control panel in the OFF position.

(2) Release the four trunk-type latches that secure the control panel to the rear of the receiver-transmitter, and remove the control panel (fig. 3-8).

(3) Remove the strobe unit by removing four binding head screws and disconnecting jack J105 from plug P105 of the strobe unit by loosening two knurled captive screws.

(4) Identify, mark, and unsolder the three connecting leads of potentiometer R103 (fig. 3-31).

(5) Remove the RANGE CONTROL hand-wheel (1) on the front of the control panel (fig. 3-43) by loosening the two setscrews (2) contained in the neck of the handwheel. Remove the hex nut seal (3).

NOTE

On first inspection of the hand-wheel, the two setscrews might not be accessible. Turn the handwheel against the limit stop until both setscrews are accessible through the outer holes of the hand-wheel.

(6) In order to gain access to potentiometer R.103 (11), remove the five binding head screws (4, 5, and 6), three hex nuts (8), and three lockwashers (7), that fasten the gearbox (10) of the dial assembly to the control panel and remove the dial assembly.

CAUTION

Care should be taken in handling the control panel to prevent damage to meter M101, the strobe unit, and the exposed wiring.

b. Invert the dial assembly so that the cover plate (16) of the dial assembly gearbox (fig. 3-43) is facing upward. Remove the three flathead screws (17) that secure the cover plate (16) to the gearbox (10).

c. Hold the handwheel shaft (14) securely in the gear assembly and carefully lift the cover plate (16). Transfer the hold to the 96-tooth bevel gear (18) on the handwheel shaft (14) and remove the cover plate (11).

NOTE

Make sure that the handwheel shaft (14) is held down at all times when removing the cover plate (11) or the dial assembly gearing will become separated.

d. Rotate the handwheel shaft (14) in a counterclockwise direction, as viewed from the RANGE CONTROL handwheel, until the internal zero stop in potentiometer R103 (11) is reached.

e. Lift the 96-tooth bevel gear (18) on the handwheel shaft (14) until the gear just disengages from the RANGE METERS indicator gear (19).

f. Rotate the RANGE METERS indicator (15), which registers the units and tenths digits, until the zero mark is centered.

g. Press the handwheel shaft (14) and 96-tooth bevel gear (18) downward in order to reengage the RANGE METERS indicator gear (19). Recheck the potentiometer zero stop against the RANGE METERS indicator reading of zero.

h. If the RANGE METERS indicator (15) does not indicate zero, repeat d through g above.

i. Replace the cover plate (16) on the dial assembly gearbox and fasten the cover plate in place with three 1440 x 1/4 flathead screws (17).

j. Check for easy rotation of the handwheel shaft (14).

k. Perform the procedures given below.

(1) Install the align the dial assembly on the rear of the control panel (fig. 3-81) and secure the dial assembly in place with two No. 832 x 5/8 binding head screws (4) (fig. 73), two No. 8-32 x 2 1/4 binding head screws (6), one No. 8-32 x 1/2 binding head screw (5), three No. 8 lockwashers (9), and three No. 8-32 hex nuts (8).

NOTE

Make sure that the potentiometer terminal lugs do not make contact with the control panel.

(2) Install the hex nut seal (3) and the RANGE CONTROL handwheel (1). Secure the handwheel in place with the two setscrews (2).

(3) Connect and solder the three previously marked leads to potentiometer R103 (11).

(4) Install the strobe unit (fig. 3-8) on the control panel and secure in place with four No. 632 x 5/8 binding head screws. Connect plug P105 to jack J'105 (fig. 3-31) and tighten the two knurled captive screws.

(5) Install the control panel on the rear of the receiver-transmitter and secure in place with the four trunk-type latches.

NOTE

Make sure that jack J101 (fig. 3-9) is in firm contact with plug P101 (fig. 3-31) of the control panel.

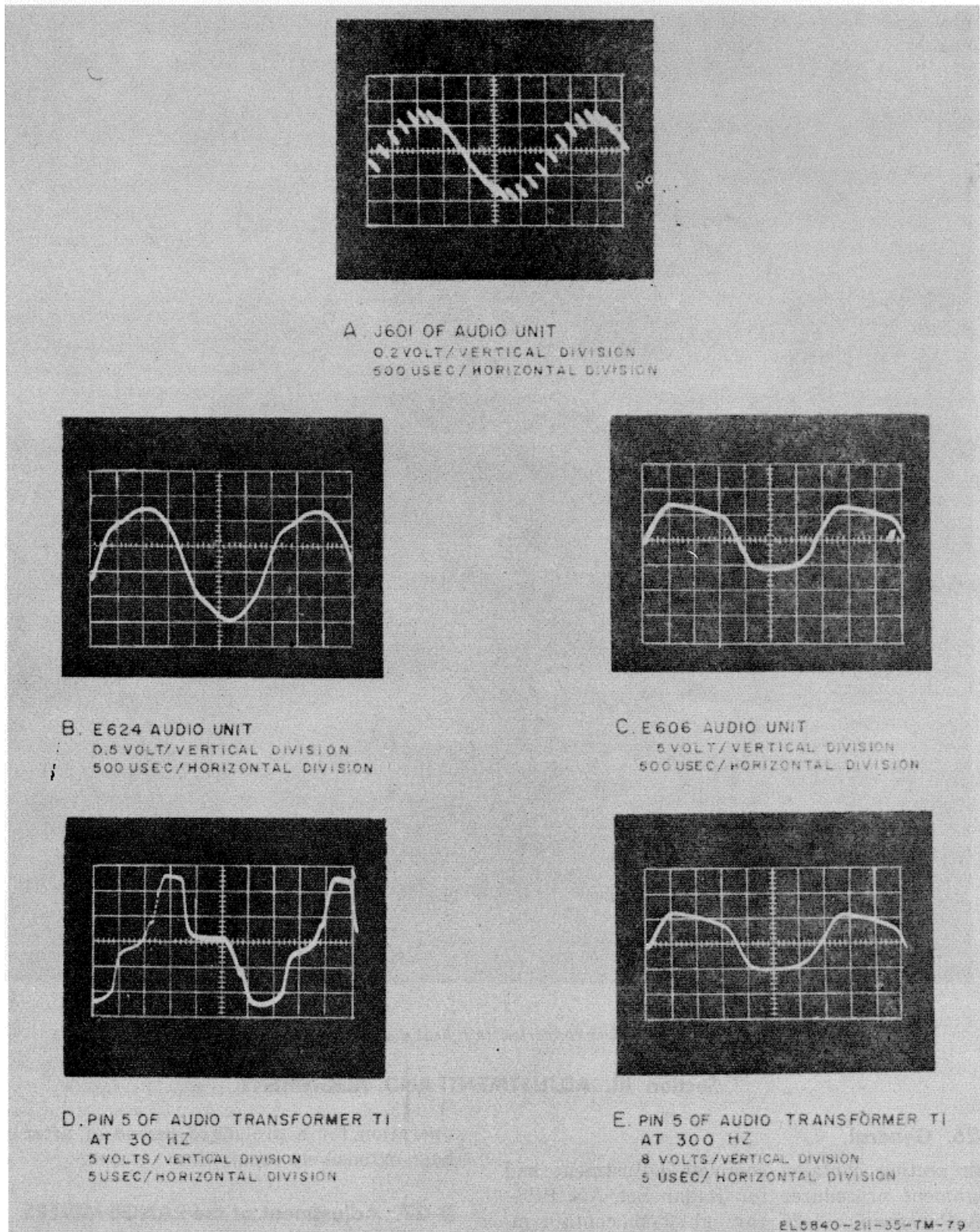

Figure 3-41. Audio unit waveforms.

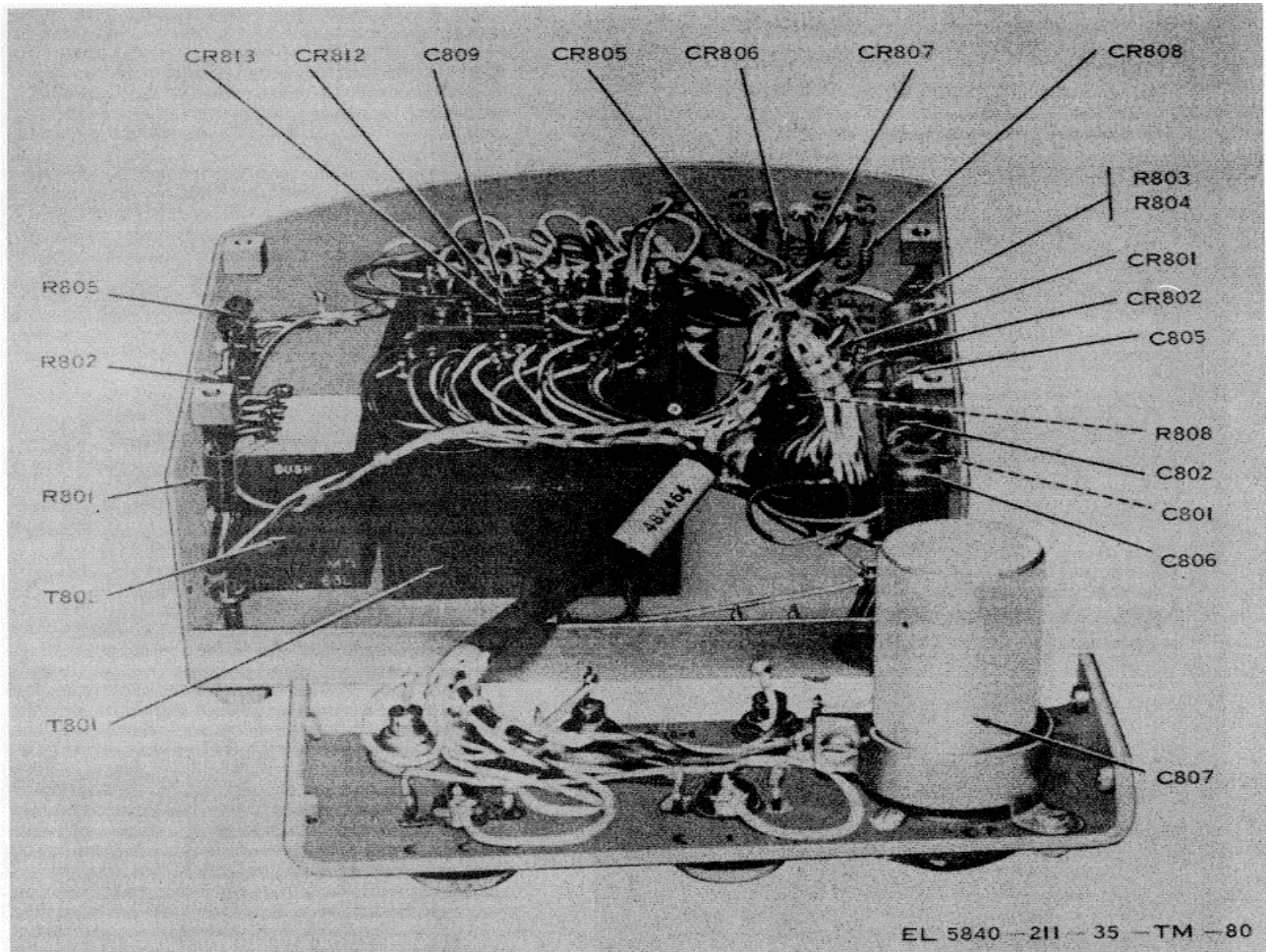

Figure 3-42. Power converter unit, heat dissipation plate removed.

Section III. ADJUSTMENT AND ALIGNMENT

3-26..General

This section contains complete adjustment and alignment procedures for Radar Set AN/PPS4A. Paragraphs 3-27 through 3-49 contain instructions for adjustments and alignment of individual systems -while paragraphs 3-48 through 3-52 contain the complete alignment procedure for the radar set. The complete alignment procedure is to be used as a guide to completely adjust and align the radar set after it has been out of operation for a prolonged period or after it

has been extensively repaired.

3-27. Adjustment of the RANGE METERS Indicator

If the RANGE METERS indicator fails to read zero when the RANGE CONTROL handwheel is turned to the full counterclockwise position, adjustment is necessary. To adjust the indicator follow the steps below.

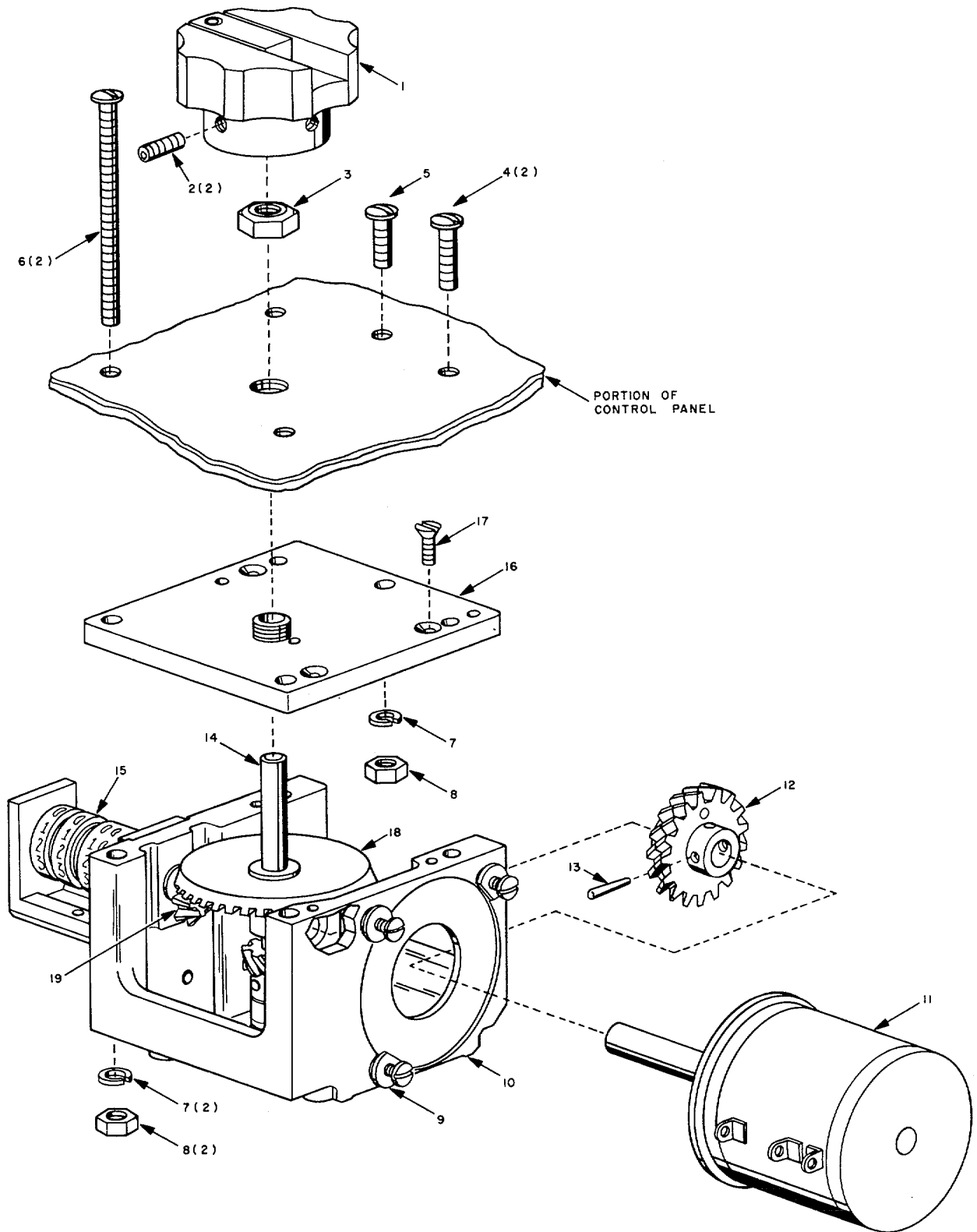

EL5840-211-35-TM-81

Figure 3-43. Dial assembly, partial exploded view

3-28. RANGE EXTENSION METERS Meter Calibration for Battery Test

a. General. The RANGE EXTENSION METERS meter deflection can be adjusted for a midscale indication when the +24-volt output of the power converter system is 24 ± 1.2 volts.

b. Procedure. To perform the RANGE EXTENSION METERS meter calibration for the battery test, proceed as follows:

- (1) Place the POWER switch in the OFF position.

CAUTION

Care should be taken in handling the control panel to prevent damage to meter M101, the strobe unit, and the exposed wiring.

(2) Remove the control panel from the rear of the receiver-transmitter by releasing the four trunk-type latches and secure the control panel in place with the support fixture (fig. 3-5).

(3) Connect the repair patch cord between jack J101 (fig. 3-13) on the center section of the receiver-transmitter and plug P101 (fig. 3-31) on the control panel.

(4) Connect a known good 24-volt storage battery (BB-422/U) to the 24V DC BAT. ONLY receptacle.

CAUTION

Approximately 24 volts will be applied to Multimeter TS-352B/U. Make sure that the multimeter is set at a range above this potential.

(5) Connect the positive lead of the multimeter to pin 6 of terminal board TB1 (fig. 3-13) on the center section. Connect the negative lead to ground, pin 7 of terminal board TB1.

CAUTION

Make sure that the VOLTAGE ADJ switch is in position 1 before turning the POWER switch to STANDBY, TRANSMIT, or RANGE.

(6) Place the POWER switch in the TRANSMIT position and wait approximately 90 seconds for the thermal delay relay to operate.

(7) Check for an indication of $+24 \pm 1.2$ volts at pin 6 of TB1 of the center section. Check for indication of +270 volts at pin 4 of TB1. On the control panel, adjust variable power supply until +270 volts is present.

(8) Depress and hold the BATTERY TEST button. Use a screwdriver to adjust potentiometer R1005 on the strobe unit affixed to the rear of the control panel (fig. 3-8).

- (9) Observe the RANGE EXTENSION

(10)

METERS meter needle while adjusting R1005. Adjust R1005 so that the meter needle is in the center of the red zone of the meter. Release the BATTERY TEST button.

(10) Place the POWER switch in the OFF position.

(11) Disconnect the voltmeter leads and remove the repair patch cord from plug P101 and jack J101.

(12) Disconnect the 24-volt storage battery (BB422/U) which was used for calibration.

(13) Install the control panel on the rear of the receiver-transmitter and fasten the four trunk-type latches that secure the control panel in place.

3-29. Range Linearity Adjustment

a. General. The RANGE CALIBRATION controls on the face of the control panel are adjusted to obtain linearity of the range sweep voltage.

b. Procedure. To adjust the range linearity, proceed as follows:

(1) Follow the range calibration procedure in TM 11-5840-211-12, and calibrate the range so that the first range mark appears at 500 ± 2 meters and the 7th range mark appears at $6,500 \pm 2$ meters.

(2) Rotate the RANGE CONTROL hand-wheel until the RANGE METERS indicator indicates 3,500 meters.

(3) Adjust potentiometer R107 (fig. 3-31) until the needle of the RANGE EXTENSION METERS meter deflects leftward to a minimum value.

(4) Check to see that the needle of the RANGE EXTENSION METERS meter deflects leftward to a minimum value at the following readings of the RANGE METERS indicator: 500 ± 2 meters, $3,500 \pm 5$ meters, and $6,500 \pm 2$ meters.

(5) If the needle of the RANGE EXTENSION METERS meter does not deflect leftward to a minimum value within the tolerances given for the 1st or 7th rangemark, repeat (1) through (4) above until it does.

3-30. Adjustment and Alignment of the Transmitting System

All adjustment and alignment procedures for the transmitting system are covered in paragraphs 3-32 and 3-33. Before making any adjustments, check the +270-volt output of the power converter system on terminal 4 of TB1 (fig. 3-13).

3-31. Tools and Test Equipment Required

a. Test Equipment. The following items of test

transmitting system:

equipment are required to adjust and align the

Test equipment	Functional name	Technical manual
Power Supply PP-1104C/G	Variable power supply	TM 11-613024612
Test Set TS-147D/UP	Radar test set	TM 11-1247B
Oscilloscope ANIUSM-281	Oscilloscope	
Repair Patchcord	Repair patch cord	Para 3-14

NOTE

When using the above test equipment in the following adjustment and alignment procedures, set the controls of the test equipment as indicated in the applicable technical manual.

b. *Tools.* Tool Equipment TE-113 is required to align and adjust the transmitting system.

(9) Connect a 50-ohm coaxial cable, terminated in its characteristic impedance, between the vertical input of the oscilloscope and the crystal output jack of the radar test set.

(10) Set the POWER switch on the control panel at TRANSMIT and observe the pulses on the oscilloscope.

(11) Adjust variable resistor R207 (fig. 3-14) to obtain a pulse width of 0.2 ± 0.2 usec at the 50% points.

(12) Adjust variable resistor R202 (fig. 3-14) until the period between pulses on the oscilloscope is from 313 to 370 microseconds.

(13) Adjust variable resistor R207 until the power output is between 24 and 27 dbm. Zero the meter on the radar test set and adjust the attenuator on the radar test set for an indication of 1 dbm on the radar test set meter. When this meter indicates 1 dbm, the total attenuation of the directional coupler (printed next to the coupler), the radar test set RF cable (TM 11-1247B), and the attenuation control are equal to the power output of the magnetron.

(14) Set the POWER switch at OFF. Remove the 50-ohm coaxial cable and replace the cap on the directional coupler cable assembly. Replace the cover plate on the directional coupler access hole. Remove the repair patch cord from jack J101 and plug P101. Replace the control panel on the receiver-transmitter and fasten the four trunk-type latches to secure the control panel in place.

3-32. Pulse Width, Repetition Rate, and Power Output Adjustments

a. *General.* The pulse width and power output are controlled by variable resistor R207. The pulse width adjustment must be made in conjunction with the power output adjustment. Variable resistor R202 controls the repetition rate of the pulses.

b. *Procedure.*

(1) Set the POWER switch on the control panel at OFF.

CAUTION

Care should be taken in handling the control panel to prevent damage to meter M101, the strobe unit, and the exposed wiring.

(2) Release the four trunk-type latches that fasten the control panel on the receiver-transmitter, and remove the control panel.

(3) Place the control panel in the support fixture.

(4) Connect the repair patch cord between plug P101 on the control panel and receptacle J101 on the rear of the center section.

(5) Unscrew the cover plate from the directional coupler access hole on the receiver-transmitter housing (fig. 3-63).

(6) Unscrew the cap of the directional coupler cable assembly.

(7) Connect the radar test set RF cable from the radar test set to jack J908 in the access hole.

(8) Place the controls on the radar test set in the transmitter position.

3-33. Magnetron Frequency Adjustment

During normal operation, the magnetron frequency is adjusted by rotating the MAG. TUNER on the magnetron. Rotation of the MAG. TUNER varies the size of the resonating cavity within the magnetron, and thus varies the magnetron frequency. To align the magnetron frequency with the klystron frequency, refer to paragraph 3-41.

3-34. Adjustment and Alignment of the Receiving System

Paragraph 3-36 and 3-32 cover all the adjustments in the receiving system. These adjustments are on the IF amplifier unit. The klystron tuning adjustment is

contained in paragraph 3-41.

3-35. Tools and Test Equipment Required

The following items of test equipment are required to completely align the receiving system:

Test equipment	Common name	Technical manual or operating parameters
Dummy Load DA-146/U	Dummy antenna	
IF Amplifier Unit Bench Test Cable	IF amplifier bench test cable	Para 3-14
IF Amplifier Unit Alignment Cover	Alignment cover.....	Para 3-14
Ground Strap	Ground strap.....	Para 3-14
Ground Plane	Ground plane.....	Para 3-14
Coaxial Cable BNC to Banana Plug.....		Para 3-14
Coaxial Cable UHF to Banana Plug.....		Para 3-14
Terminated Test Cable.....	Terminated test cable.....	Para 3-14
Generator Signal TS-452A/U	Sweep generator	
Oscilloscope AN/USM-281	Oscilloscope	
Repair Patch Cord.....	Repair patchcord	Para 3-14
Multimeter meter ME-26B/U.....	Vacuum tube voltmeter	
Insulated Tuning Tool A	Tuning tool A.	Para 3-14
Insulated Tuning Tool B	Tuning tool B	Para 3-14
Multimeter TS-352/U	Multimeter.....	TM 11-6625-366-15
Dummy Mixer	Dummy mixer	Para 3-14

3-36. Bandwidth and Gain Adjustment Test Equipment Setup

a. *General.* The seven tuning networks of the IF amplifier unit (six interstage networks and the input network) are separately adjusted to give an overall gain of approximately 85 db and a bandwidth of 5.5 to 7 MHz. The test equipment setup procedure for this adjustment is given in, b below. The procedure for the adjustment is given in paragraph 3-37.

b. *Test Equipment Setup Procedures.* To set up the test equipment (fig. 3-44) for the bandwidth and gain adjustment (para 337), follow the steps given below.

(1) Release the four trunk-type latches that fasten the control panel on the receiver-transmitter, and remove the control panel.

CAUTION

Care should be taken in handling the control panel to prevent damage to meter M101, the strobe unit, and the exposed wiring.

(2) Release the four trunk type latches that fasten the radome on the receiver-transmitter and remove the radome with the reflector attached.

CAUTION

Care should be taken to prevent denting the reflector or damaging the dipoles of the antenna feed.

(3) Place the control panel in the support fixture.
 (4) Connect the repair patchcord between plug P101 on the control panel and jack J101 on the center section.

(5) Remove the antenna feed assembly from hybrid waveguide assembly No. 1 by removing the four binding head screws and four lockwashers from the antenna feed assembly flange.

(6) Secure a dummy antenna to the flange of hybrid waveguide assembly No. 1 with the four No. 8032 x 1/2 binding head screws and four No. 8 lockwashers removed in (5) above.

WARNING

Interlock switch S1 is a protection against dangerous voltages. Review the warning procedures in paragraph 3-7 before disabling the switch.

(7) Disable interlock switch S1 (fig. 3-1) by pulling the interlock shaft to the full forward position.

(8) Remove the IF amplifier unit from the mounting plate in the receiver-transmitter center section (para 3-6). Connect the IF amplifier bench test cable between jack J501 on the IF amplifier unit and plug P501 on center section mounting plate.

(9) Remove the nine No. 4-40 x 4/16 binding head screws and nine No. 4 lockwashers that fasten the cover on the IF amplifier unit and remove the cover.

(10) Using a jewelers' screwdriver, turn variable capacitors 053, 0576, C516, 0521, C524, 0526, and 0533 counterclockwise in order to break the factory seal. Check that these capacitors turn freely before proceeding to (11) below.

(11) Install the alignment cover using the screws and lockwashers removed in (9) above. Check that all screws are secured tightly.

(12) Replace the audio, afc, transmitter, and range units as described in paragraphs 3-64, 365, -61, and 3-62 respectively. Do not connect plug P603 to jack J702 on the afc unit.

(13) Connect the coaxial cable with microdot connector between jack J206 on the transmitter unit and plug P508 on the blanking pulse cable.

(14) Use a ground strap to ground the receiver-transmitter, the IF amplifier unit, and all test equipment to the ground plane.

(15) Connect one end of a 33,000-ohm resistor to the center lead of a coaxial cable.

(16) Connect the outside shield of the coaxial cable to an alligator clip and connect the alligator clip to the chassis of the IF amplifier unit.

(17) Connect the other end of the coaxial cable to the input of the sweep generator.

(18) Connect the terminated test cable to the output of the sweep generator.

(19) Set the output of the sweep generator with no attenuation added to give an output signal of approximately 0.5 volt rms as the terminated end of the terminated test cable. Measure the output of the test cable with a vacuum tube voltmeter. Set the sweep control on the sweep generator to obtain a sweep centered at 30 MHz with the sweep length set at a maximum value on the sweep generator.

(20) On the control panel of the radar set, set the POWER switch at RANGE; set the RANGE METERS indicator at 7,000.

(21) Using tuning tool A, adjust resistor R61,5 fully counterclockwise. With the multimeter, observe the output at jack J602 on the audio unit. Vary the VOLUME control until the output voltage at jack J602 on the audio unit is approximately -4.4 volts.

(22) Set the POWER switch at OFF.

3-37. Bandwidth and Gain Adjustment Procedure

a. General. When performing the bandwidth and gain adjustment procedure, the following factors should be taken into consideration.

(1) In the bandwidth and gain adjustment procedure, turning the variable coupling capacitor of each stage clockwise broadens the response curve

viewed on the oscilloscope, for that stage, and sometimes causes the response curve to become asymmetrical. Adjusting the primary and secondary inductors in the stage and readjusting the coupling capacitor will restore the symmetry at the desired bandwidth. If the dip in the response curve is 3 db or greater, adjust the coupling capacitor slightly counterclockwise and readjust the primary and secondary inductors. Do not allow the dip to remain at or below the 3-db point.

(2) In many instances, it will be possible to obtain the ideal response curve for the stages (fig. 3-45). Figure 3-46 illustrates typical response curves which are acceptable even though they deviate from the ideal. Therefore, a stage is considered properly adjusted when either the ideal or the typical response curve is obtained on the oscilloscope.

(3) Due to the interaction of a double tuned network, it may be necessary to tune the primary and secondary inductors and the coupling capacitor several times to obtain the required response curve for that stage.

(4) As each stage is tuned, the bandwidth tends to become narrower. Therefore, tune each stage carefully to obtain the proper bandwidth as illustrated in figures 3-45 and 3-46.

(5) In the following adjustment procedure (*b* below), the cold side of the capacitor is the side closest to ground potential and is indicated as the curved side on the schematic symbol for a capacitor.

(6) In the following adjustment procedure, when instructed to retrim a stage, adjust the coupling capacitor of the stage until the response curve tends to flatten; readjust the primary and secondary inductors of that stage to center the response at 30 MHz with the proper symmetry.

Continue to alternately adjust the coupling capacitor and both inductors a little at a time until the correct response curve is obtained for the stage.

b. First Adjustment.

(1) Connect the terminated end of the terminated test cable to the cold side of coupling capacitor C526 through hole B in the alignment cover (fig. 3-44). Connect the ground terminal of the coaxial cable to the IF amplifier unit chassis. Connect a 1,000- μ f capacitor between the cold side of capacitor C524 and ground by connecting one clip on the 1,000- μ f capacitor to a screw on the alignment cover and the other clip to the cold side of capacitor C524 through hole C in the alignment cover.

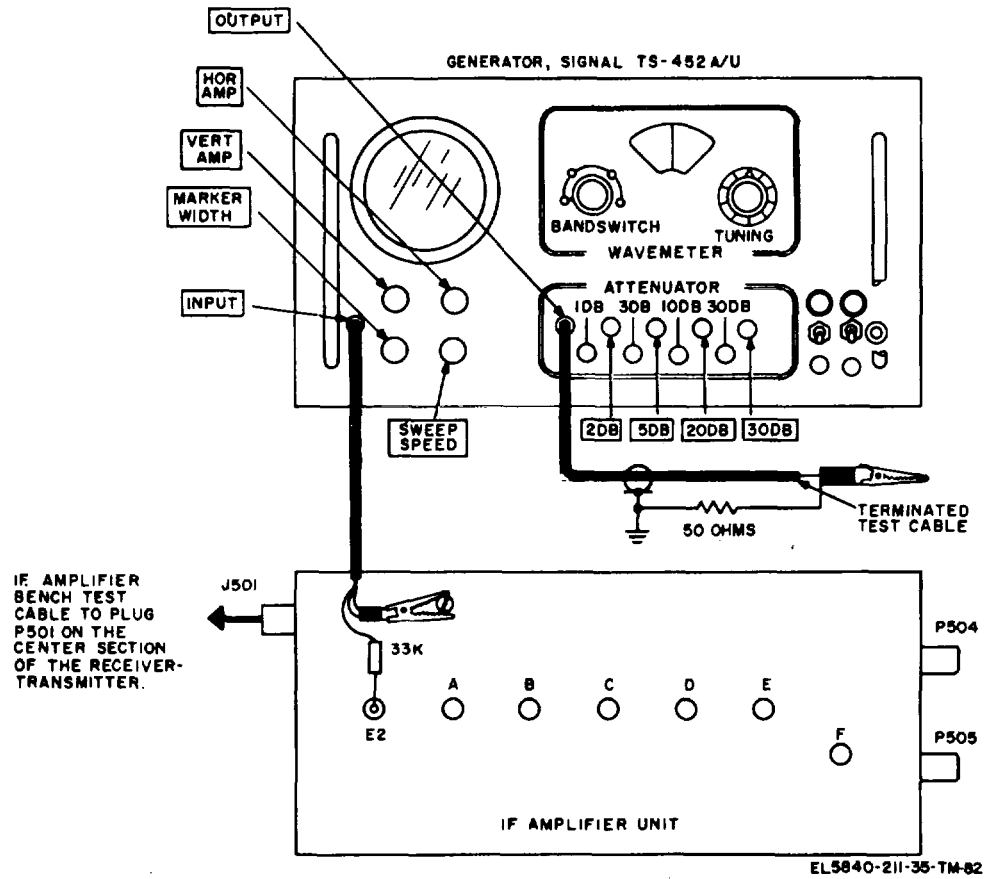

Figure 3-44. Bandwidth and gain adjustment test equipment setup.

- (2) Set the POWER switch at TRANSMIT.
- (3) Place enough attenuation (approx 10 db) on the step attenuator to give a response of approximately 0.5 volt as indicated on the oscilloscope.
- (4) Using tuning tool A, turn the plunger of capacitor C633 (hole A in the alignment cover) clockwise approximately 2 turns.
- (5) Set the frequency markers of the sweep generator at 25, 30, and 35 MHz.
- (6) Using tuning tool B, adjust secondary inductor L521 to peak the response curve at the 30-MHz marker on the oscilloscope.
- (7) Using tuning tools B and A, adjust primary inductor L526 and capacitor C533 until the response curve is symmetrical about the 25to 35-MHz markers on the oscilloscope. In order to observe the symmetry of the response curve, set the center of the sweep control on the sweep generator at 25 MHz, at 30 MHz, and then at 35 MHz.
- (8) Adjust capacitor C533 (hole A in the alignment cover) clockwise and retrim the stage until the response curve on the oscilloscope is similar to that illustrated in A, figure 3-46 or A, figure 3-45.

- (9) Set the POWER switch at OFF.

c. *Second Adjustment.*

- (1) Connect the terminated end of the terminated test cable to the cold side of coupling capacitor C524 through hole C in the alignment cover. Connect the ground terminal of the test cable to the IF amplifier unit chassis. Connect the 1,000-c,Af capacitor between ground and the cold side of capacitor C521 through hole D in the alignment cover.
- (2) Set the POWER switch at TRANSMIT.
- (3) Insert approximately 15 db more attenuation on the step attenuator to obtain a response of approximately 0.5 volt on the oscilloscope.
- (4) Using tuning tool A, turn the plunger of capacitor 0526 (hole B in the alignment cover) clockwise approximately 2 turns.
- (5) Set the frequency markers of the sweep generator at 25, 30, and 35 MHz.
- (6) Using tuning tool B, adjust secondary inductor L538 to peak the response curve around p the 30-MHz marker on the oscilloscope.
- (7) Using tuning tools B and A, adjust primary inductor L525 and capacitor C526 until

the response curve is symmetrical about the 25 and 35-MHz markers on the oscilloscope, and is centered about the 30-MHz marker. In order to observe the symmetry of the response curve, set the center of the sweep control on the sweep generator at 30 MHz.

(8) Using tuning tool A, adjust the plunger on capacitor C526 (hole B in the alignment cover) and retrim the stage until the response curve on the oscilloscope is similar to that illustrated in B, figure 3-46 or B, figure 3-45.

(9) Set the POWER switch at OFF.

d. Third Adjustment.

(1) Connect the terminated end of the terminated test cable to the cold side of coupling capacitor C521 through hole D in the alignment cover. Connect the ground terminal of the test cable to the IF amplifier unit chassis. Connect the 1,000-pF capacitor between ground and the cold side of capacitor C515 (hole E in the alignment cover).

(2) Set the POWER switch at TRANSMIT.

(3) Insert approximately 15 db more attenuation on the step attenuator to obtain a response of approximately 0.5 volt on the oscilloscope.

(4) Using insulated tuning tool A, turn the plunger of capacitor C524 clockwise approximately 2 turns.

(5) Set the crystal frequency markers of the sweep generator at 25, 30, and 35 MHz.

(6) Using tuning tool B, adjust secondary inductor L537 to peak the response curve around or as close as possible to the 30-MHz marker on this oscilloscope.

(7) Using tuning tools B and A, adjust primary inductor L524 and capacitor C524 until the response curve is symmetrical about the 25 and 35-MHz markers on the oscilloscope and is centered about the 30-MHz marker. If complete symmetry cannot be obtained, proceed to next step.

(8) Using tuning tool A, adjust the plunger of capacitor C524 clockwise and retrim the stage until the response curve on the oscilloscope is similar to that illustrated in C, figure 346 or C, figure 345.

(9) Set the POWER switch at OFF.

e. Fourth Adjustment.

(1) Set the variable marker on the sweep generator at 27 MHz. Using a grease pencil, mark the point on the oscilloscope corresponding to the 27-MHz marker. Set the variable marker on the sweep generator at 33 MHz. Using a grease pencil, mark the point on the

oscilloscope corresponding to the 33-MHz marker.

(2) Connect the terminated end of the terminated test cable to the cold side of coupling capacitor C515 through hole E in the alignment cover. Connect the ground terminal of the test cable to the IF amplifier unit chassis. Connect the 1,000-pF capacitor between ground and the cold side of capacitor C576 (hole F in the alignment cover).

(3) Set the POWER switch at TRANSMIT.

(4) Insert approximately 15 db more attenuation on the step attenuator to obtain a response of approximately 0.5 volt on the oscilloscope.

(5) Using tuning tool A, turn the plunger of capacitor C521 clockwise approximately 2 turns.

(6) Set the frequency marker of the sweep generator at 30 MHz.

(7) Using tuning tool B, adjust secondary inductor L536 to peak the response curve around the 30-MHz marker on the oscilloscope. If more than one peak is observed, adjust inductor L536 so that the center of the response is located at the 30-MHz marker.

(8) Using tuning tools B and A, adjust primary inductor L523 and capacitor C521 until the response curve is symmetrical about the 27 and 33-MHz markers on the oscilloscope and is centered about the 30-MHz marker.

(9) Using tuning tool A, adjust the plunger on capacitor C521 clockwise and retrim the stage until the response curve on the oscilloscope is similar to that illustrated in D, figure 3-46 or D, figure 3-45.

(10) Set the POWER switch at OFF.

f. Fifth Adjustment.

(1) Disconnect the 1,000-pF capacitor from capacitor C576. Connect the terminated end of the terminated test cable to the cold side of coupling capacitor C576 through hole F in the alignment cover. Connect the ground terminal of the coaxial cable to the IF amplifier unit chassis.

(2) Set the POWER switch at TRANSMIT.

(3) Insert approximately 15 db more attenuation on the step attenuator to obtain a response of approximately 0.5 volt on the oscilloscope.

(4) Using tuning tool A, turn the plunger of capacitor C515 clockwise approximately 2 turns.

(5) Set the frequency marker of the sweep generator at 30 MHz.

(6) Using tuning tool B, adjust secondary inductor L535 to center the response curve around

the 30-MHz marker on the oscilloscope, even though the response may appear asymmetrical.

(7) Using tuning tools B and A, adjust primary inductor L522 and capacitor C515 until the response curve is as symmetrical as possible about the 27 and 33-MHz markers on the oscilloscope and is centered about the 30-MHz marker.

(8) Using tuning tool A, adjust the plunger on capacitor C51,5 clockwise and retrim the stage until the response curve on the oscilloscope is similar to that illustrated in E, figure 3-46 or E, figure 3-45.

(9) Set the POWER switch at OFF.

g. Sixth Adjustment.

(1) Set the variable marker on the sweep generator at 27.2 MHz. Using a grease pencil, mark the point on the oscilloscope corresponding to the 27.3-MHz marker. Set the variable marker at 32.7 MHz. Using a grease pencil, mark the point on the oscilloscope corresponding to the 32.7-MHz marker.

(2) Disconnect the terminated test cable from the signal-generator. Connect a BNC to BNC coaxial cable between the step attenuator and the input jack on the dummy mixer. Connect plugs P504 and P505 to the output jacks on the dummy mixer (fig. 3-47).

(3) Set the POWER switch at TRANSMIT.

(4) Insert approximately 20 db more attenuation on the step attenuator to obtain a response of approximately 0.5 volt on the oscilloscope.

(5) Using tuning tool A, turn the plunger of capacitor C576 approximately 2 turns clockwise.

(6) Using tuning tool B, adjust primary inductor L510 to center the response curve around the 30-MHz marker on the oscilloscope.

(7) Using tuning tool B, adjust secondary inductor L539 until the response curve is symmetrical about the 30-MHz marker on the oscilloscope.

(8) Using tuning tool B, adjust input tuning inductor L507 to center the response curve around the 30-MHz marker.

(9) Using tuning tool A, adjust the plunger on capacitor C576 clockwise, and adjust inductors L510 and L539 until the response curve is as similar as possible to that illustrated in F, figure 3-46 or F, figure 3-45.

(10) Adjust capacitor C553 and inductor L507 until the response curve is similar to that illustrated in F, figure 3-46 or F, figure 3-45. If the response is not centered about the 30-MHz marker, readjust inductors L510, L539, and L507.

(11) Set the POWER switch at OFF.

h. Gain Requirements.

(1) Disconnect the dummy mixer from the signal generator. Connect the terminated test cable to the step attenuator.

(2) Set the output of the sweep generator (with no attenuation added) to give an output signal of approximately 0.43 volt rms at the terminated end of the terminated test cable as measured with the vacuum tube voltmeter.

(3) Disconnect the terminated test cable from the signal generator. Connect the step attenuator to the input jack of the dummy mixer.

(4) Set the POWER switch at TRANSMIT.

(5) Vary the VOLTAGE control until the output voltage at jack J602 on the audio unit is approximately -4.4 volts as measured with the multimeter.

(6) Adjust the step attenuator to obtain a response of 0.5 volt on the oscilloscope. The attenuation should be 85 db or greater. If it is not, repeat the entire adjustment procedure beginning with a above.

(7) Set the POWER switch at OFF.

i. Bandwidth Requirements.

(1) Set the POWER switch at TRANSMIT.

(2) Insert 3 db more attenuation on the step attenuator.

(3) Using a grease pencil, draw a line on the oscilloscope at the upper limit of the response curve.

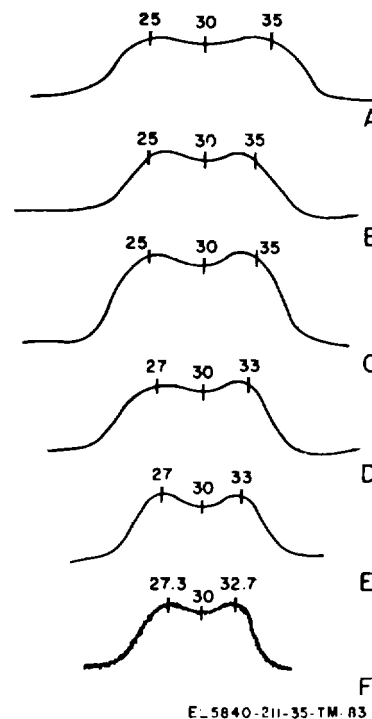

Figure 3-45. Idea response curves for bandwidth and gain adjustment

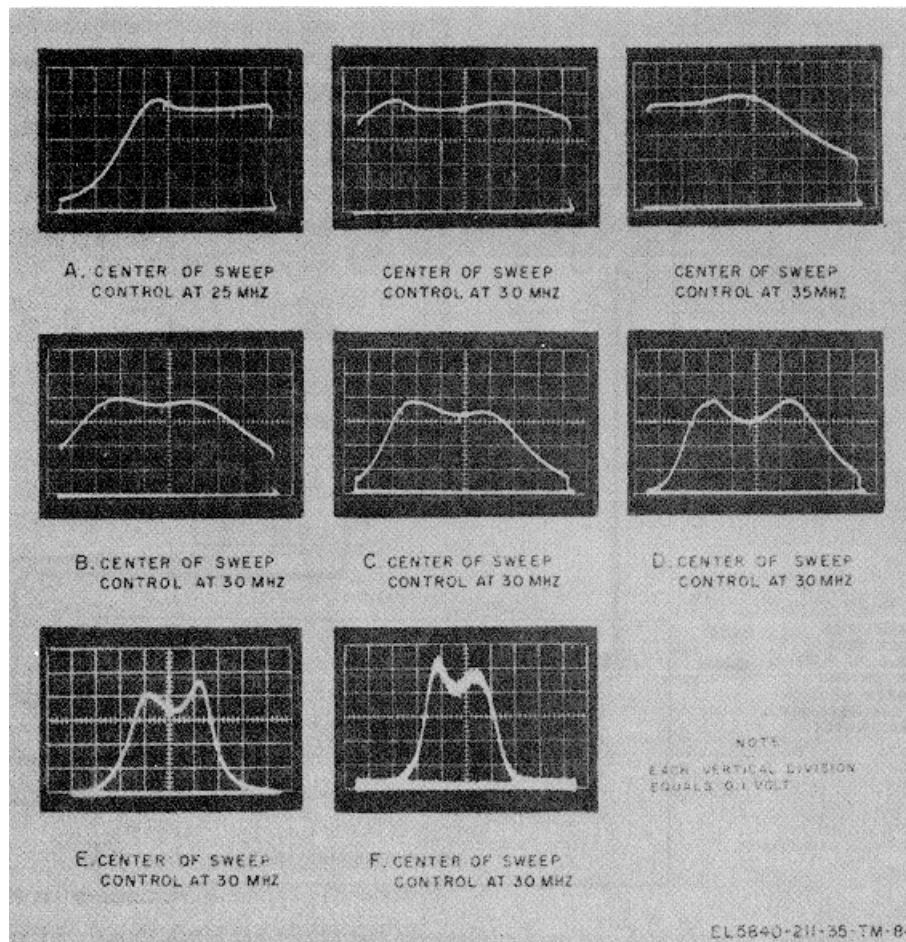

Figure 3-46. Typical response curves for bandwidth and gain adjustment.

(4) Remove 3-db attenuation on the step attenuator.

(5) Adjust the variable frequency marker on the sweep generator until the marker coincides with one of the points at which the response curve crosses the line drawn in (3) above on the oscilloscope. Note the value at which the variable frequency marker is set.

(6) Adjust the variable frequency marker on the sweep generator until the marker coincides with the second point at which the response curve crossed the line drawn in (3) above on the oscilloscope. Note the value at which the variable frequency marker is set. The bandwidth, difference between this value and the value noted in (6), above should be no less than 5.6 MHz nor greater than 7 MHz. If the bandwidth is not within these limits, repeat the entire adjustment procedure beginning with a above. Observe the response at each stage. When the proper response cannot be obtained for a stage, adjust that stage, and check and/or adjust all previous stages.

(7) Set the POWER switch at OFF.

(8) Deenergize all test equipment.

Remove all test cables and the repair patchcord. Remove the audio, afc, transmitter, and range units (para 3-64, 3-65, 3-61, and 3-62 respectively). Remove the alignment cover, and install the IF amplifier unit cover with nine No. 4-40 x 1/2 binding head screws and nine No. 4 lockwashers. Replace the IF amplifier unit in the receive-transmitter (para 3-63). Replace the audio, afc, transmitter, and range units (paras 3-64, 3-5, 3-61, and 3-62).

Replace the control panel on the receiver-transmitter and fasten the control panel in place with the four *trunk-type* latches.

(9) Remove the dummy antenna from the flange of hybrid waveguide assembly No. 1 by removing the four binding head screws and four lockwashers from the dummy antenna. Secure the antenna feed assembly to hybrid waveguide assembly No. 1 with the four No. 8-32 x 1/2 binding head screws and four No. 8 lockwashers removed above. Replace the radome on

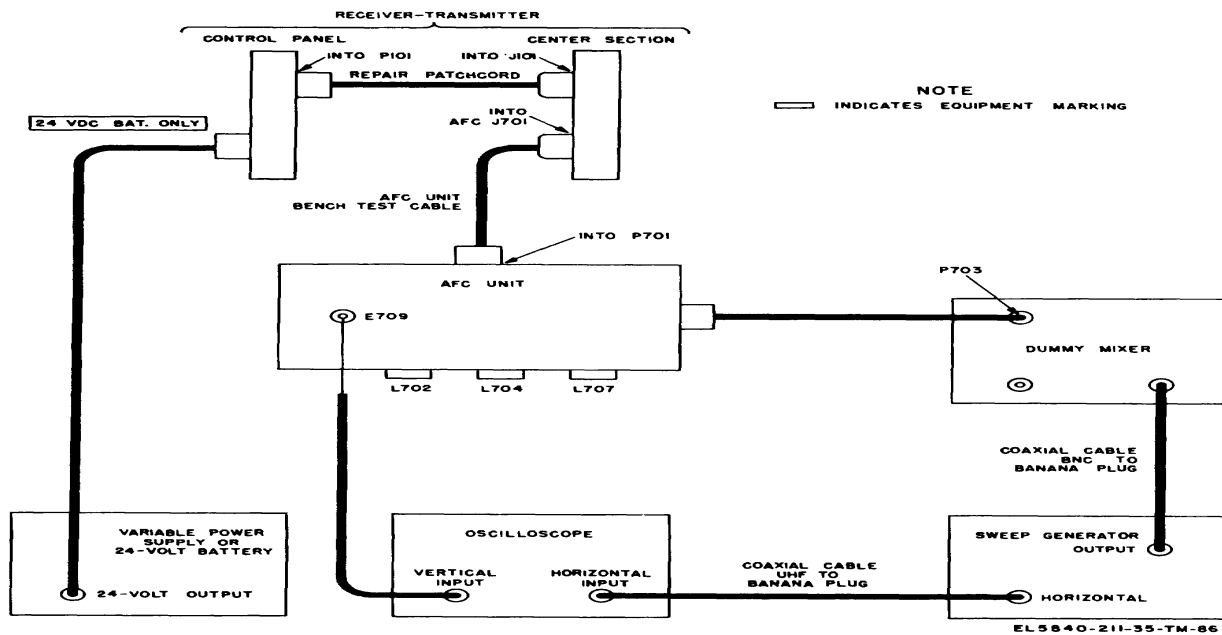

Figure 3-47. Bandwidth and gain adjustment test equipment setup. the receiver-transmitter and fasten the radon in place with the four trunk-type latches.

- (1) Afc unit tuning adjustments L702, L704, and L707.
- (2) Klystron tuning adjustment.
- (3) Magnetron tuning adjustment.
- (4) Afc sweep adjustment R632.

3-38. Adjustment and Alignment of the Automatic Frequency Control System

a. The following paragraphs cover all adjustments in the afc system. These adjustment are in the afc unit and should be made with th afc unit removed from the receiver-transmitter b. The following are the adjustments associate with the afc system:

3-39. Tools and Test Equipment Required

a. *Test Equipment.* The following items of test equipment are required to completely align the afc system.

Test equipment	Functional name	Technical manual or operating parameters
Spectrum Analyzer TS-148/UP	Spectrum analyzer.....	TM 11-1249
Oscilloscope AN/USM-281	Oscilloscope	
Signal Generator TS-452A/U	Sweep generator	TM 111-66 83-12
Generator, Pulse SG-366/U.....	Pulse generator	
Multimeter, Meter ME-6B/U	Vacuum tube voltmeter	TM 11-66o5-200-15
Multimeter TS,E-Z2B/U	Milliammeter	T M 11-6625-366-15
Dummy Mixer	Dummy mixerPara 3-14	
Repair Patchcord	Repair patchcord.....	Para 3-14
Afc Unit Bench Test Cable.....	Af bench test cable	Para 314

b. *Tools.* Tool Equipment TE-119 is required to completely align the afc system.

3-40. Afc Unit Tuning Adjustment L702, LU04, and L707

a. *General.* Afc unit tuning adjustments L702, L704, and L707 are adjusted so that the afc system gives the desired response to the pulsed IF input signals.

b. *Procedure.* To adjust L702, L704, and L707, proceed as follows: (1) Remove the afc unit from the mounting plate of the receiver-transmitter center section and remove the cover by following the procedure in paragraph 3-65.

(2) Connect the afc unit to the receiver transmitter and test equipment as shown, in figure 3-48.

(3) When the afc unit is connected to the test equipment as shown in figure 3-48, the sweep generator and dummy mixer perform the function of the RF system by generating the input to the afc unit.

(4) Turn on the oscilloscope and set the horizontal display switch so that the oscilloscope sweep will be generated from the output of the signal generator.

(5) The following procedure is followed to turn on and use the sweep generator: (a) Connect the vacuum tube voltmeter across the input terminals of the dummy mixer.

(b) Set the frequency control of the sweep generator at 30 MHz.

(c) Set the attenuator switches on the sweep generator to obtain no attenuation.

(d) Turn on the sweep generator.

(e) Adjust the output control of the sweep generator until an indication of 0.8 volt rms is obtained on the vacuum tube voltmeter.

(f) Set the attenuator switches on the sweep generator to obtain an attenuation of 35 db.

(6) Turn the POWER switch on the control panel to the STANDBY position.

(7) The afc discriminator response (fig. 3-49) will be displayed on the oscilloscope.

(8) Set the variable marker control on the sweep generator to read 30 MHz.

(9) Adjust inductor L707 on the afc unit (fig. 3-59) until f., the crossover frequency, coincides with the position of the variable marker as viewed on the oscilloscope.

(10) Adjust L702 and L704 on the afc unit until the afc. discriminator response displayed on

the oscilloscope appears similar to that shown in figure 107. In adjusting L702 and L704 it is necessary to compromise between the maximum slope of the afc discriminator response at the crossover frequency and the maximum amplitude at the positive and negative peaks. The line through the crossover frequency point should be a straight line and the peaks should be equal and greater than 0.3 volt in amplitude, separated by 5.5 +1.5 MHz, and centered about the crossover frequency.

(11) Due to the interaction of inductors L702, L704 and L707. (9) and (10) above must be repeated at least twice in order to obtain an accurate response.

(12) Replace the sweep generator in figure 348 with a pulse generator and disconnect the oscilloscope from E709 on the afc unit.

(13) Set the pulse generator frequency control at 30 +0.1 MHz and the repetition rate at 4.5 +0.5 kHz.

(14) Connect the oscilloscope across the dummy mixer input terminals.

(15) Adjust the pulse width control on the pulse generator so that 0.3+0.03 microsecond pulses are obtained on the oscilloscope. (Normally this will call for the minimum setting of the pulse width control.) Disconnect the oscilloscope from the test setup.

(16) Adjust the output control of the pulse generator until an output voltage of 0.2 volt rms is obtained. To measure the output voltage on the pulse generator panel meter it is necessary to set the mode selector switch for generation of a continuous wave output and to set the attenuator switches on the pulse generator for no attenuation. After the output voltage is set at 0.2 volt rms, return the mode selector switch to the position where the output consists of RF pulses.

(17) Connect a vacuum tube voltmeter between jack J604 on the audio unit and ground. Set AFC/MFC switch S601 on the audio unit at MFC, and adjust potentiometer R632 on the audio unit to obtain a reading of -110 volts on the vacuum tube voltmeter.

CAUTION

Make sure that jack J604 on the audio unit does not short to ground. Do not connect a low resistance between jack J604 and ground. Jack J604 has a potential of -110 volts with respect to ground. A low resistance between jack J604 and ground may cause permanent damage to the audio unit.

(18) Set the attenuator switches on the pulse generator for an attenuation of 8 +2 db, and set AFC/MFC switch S601 at AFC.

(19) Adjust inductor L707 until the voltage at jack J604 is -110 volts.

(20) Insert an additional 3 db of attenuation by means of the attenuator switches on the pulse generator.

(21) Slowly increase the frequency of the pulse generator output until a reading of -110 volts is again obtained on the vacuum tube voltmeter at jack J604. If the new frequency is above 31 MHz perform (22) below; if it is at or below 31 MHz proceed to (23) below.

(22) Set the frequency of the pulse generator at 31+0.1 MHz and adjust inductor L704 on the afc unit to obtain -110 volts at jack J604 of the audio unit.

(23) Decrease the attenuation of the pulse generator by 6 db below the level set in (18) above.

(24) Slowly reduce the frequency of the pulse generator until the voltage at jack J604 is -110 volts. If the new frequency is below 29 MHz perform (25); if it is at or above 29 MHz proceed to (26) below.

(25) Set the frequency of the pulse generator at 29 +0.1. MHz and adjust inductor L702 on the afc unit to obtain -110 volts at jack J604.

(26) Slowly reduce the frequency of the pulse generator output. The voltage at jack J604 should become more negative and reach a saturation value of -159 + 1 volts, at a frequency not lower than 27 MHz. There should be no further change in this voltage as the frequency is decreased to 22 MHz.

NOTE

The procedure of (26) above insures that lock-on will not occur at a false signal.

(27) When alignment is satisfactory, cement the tuning slugs of inductors L702, L704, and L707 in place with Compound, Sealing, Locking Retaining, Grade EV, Bottle NSN 8030-00-614-9207.

(28) Deenergize all test equipment. Remove all test cables and the repair patch cord. Follow the procedure of paragraph 3-65 to replace the afc unit in the receiver-transmitter.

3-41. Afc Sweep Adjustment R632 and Klystron V902 and Magnetron V901 Tuning Adjustments

NOTE

The radar set must not be tuned above 9,400 MHz because instability of the radar set will develop.

a. *General.* The klystron V902 and magnetron V901 tuning adjustments are performed in conjunction with afc sweep adjustment R632 in order to maintain the difference between the klystron and magnetron frequencies at 30 MHz.

CAUTION

Care should be taken in handling the control panel to prevent damage to meter M101, the strobe unit, and the exposed wiring.

b. *Procedure.* To perform the adjustments, proceed as follows:

(1) Release the four trunk-type latches that secure the control panel to the receiver-transmitter housing, remove the control panel, and place it in the support fixture.

(2) Release the four trunk-type latches that secure the radome to the receiver-transmitter housing, and remove the radome.

(3) Remove the antenna feed assembly from hybrid waveguide assembly No. 1 (fig. 3-50) by removing the four binding head screws and four lockwashers from the antenna feed assembly flange.

(4) Secure a dummy antenna to the flange of hybrid waveguide assembly No. 1 with the four No. 8-32 x 1/2 binding head screws and four No. 8 lockwashers removed in (3) above.

(5) Install the repair patchcord between plug P 101 on the control panel (fig. 3-31) and jack J101 on the center section (fig. 3-13).

(6) Connect the milliammeter to jack J506 or J507 on the IF amplifier unit (fig. 3-56).

NOTE

Outputs at jacks J506 and J507 are of opposite polarity.

(7) Disable interlock switch S1 (fig. 3-50) by pulling the interlock shaft to the full forward position, and set the POWER switch at TRANSMIT.

(8) Position the pickup horn of the spectrum analyzer adjacent to klystron V902 as shown in figure 3-50.

(9) Adjust the spectrum analyzer controls until a frequency spectrum (fig. 3-51) appears on the spectrum analyzer oscilloscope. Note that the magnetron frequency display and the klystron frequency display are obtainable on the spectrum analyzer.

(10) Measure the magnetron frequency at the peak of the displayed spectrum. If necessary, loosen the screw which secures the MAG. TUN-

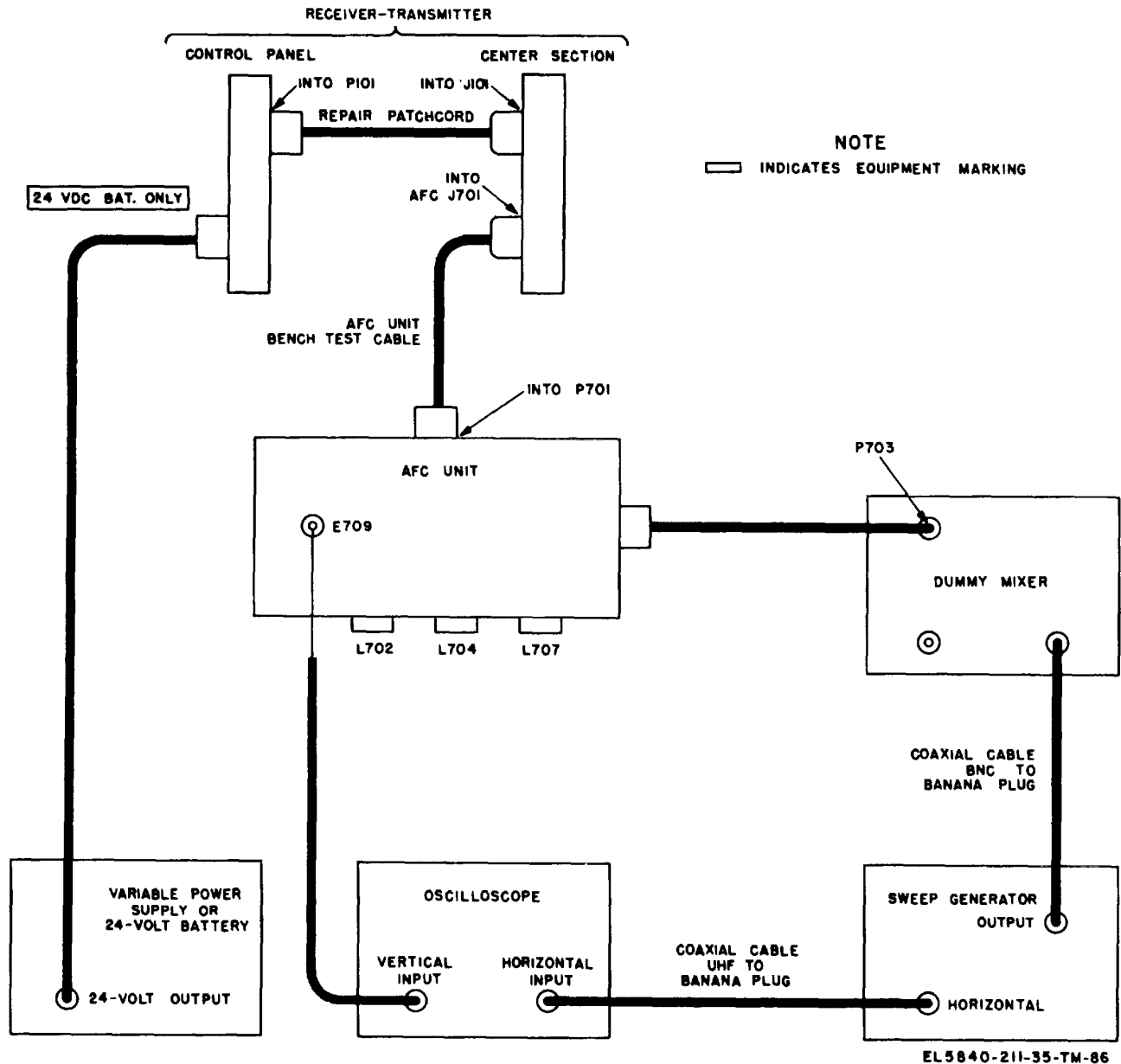

Figure 3-48. Afc unit alignment test setup.

ER (fig. 3-50) to the tuning shaft and adjust the tuning shaft until the desired magnetron frequency is obtained. Tighten the screw to secure the MAG. TUNER to the tuning shaft.

(11) Set AFC/MFC switch S601 on the audio unit (fig. 3-58) at MFC.

(12) Connect a vacuum tube voltmeter between jack J604 of the audio unit and ground.

(13) In order to ensure that klystron V902 is operating in the correct mode, set potentiometer R632 on the audio unit to the extreme clockwise position. Adjust potentiometer R632 in a counterclockwise direction until

a maximum reading is observed on the milliammeter.

(14) Using the klystron tuning tool which is mounted on the receiver-transmitter center section (fig. 3-50), adjust the klystron tuning knob until the klystron frequency is 30 ± 2 MHz above the magnetron frequency as observed on the displayed frequency spectrum (fig. 3-5'1).

(15) Readjust potentiometer R632 on the audio unit (fig. 3-58) until maximum current is again observed on the milliammeter.

(16) Repeat the procedure given in (14) and (15) above until the klystron frequency is 30 ± 2 MHz above the magnetron frequency as observed

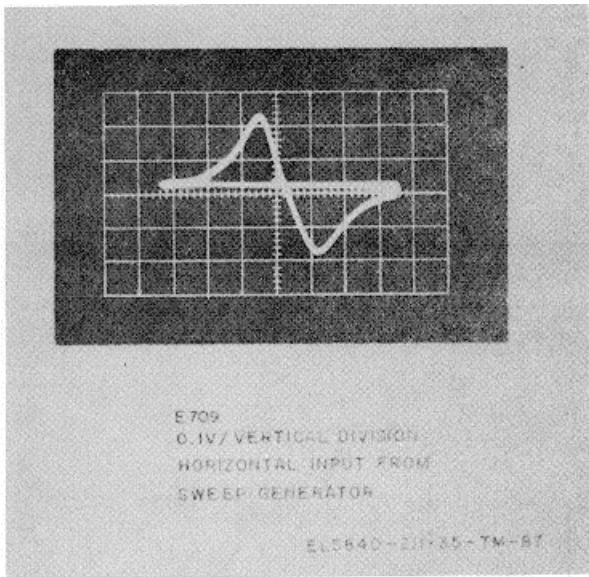

Figure 3-49. Afc discriminator response.

on the displayed frequency spectrum (fig. 3-51') and until maximum current is observed on the milliammeter. Note that readjustment of potentiometer R632 ((1'5) above) affects the results given in (14) above. Readjustment of the klystron tuning knob ((14) above) affects the results given in ((14) above).

(17) Loosen the setscrew which locks the position of the local oscillator attenuator (fig. 50) and adjust the local oscillator attenuator until a reading between 0.5 and 1.0 ma is obtained on the milliammeter connected to jack J506 or J507. Tighten the setscrew to lock the local oscillator attenuator in this position.

(18) Set AFC/MFC switch S601 on the audio unit (fig. 3-58) at AFC. Lock-on should occur as a result of the afc action, with the klystron frequency 30 ± 1 MHz above the magnetron frequency as observed on the displayed frequency spectrum.

NOTE

Perform (19) below only if one of the following three conditions exists, otherwise proceed to (20) below: lock-on does not occur, lock-on occurs at the image frequency with the klystron frequency approximately 35 MHz below the magnetron frequency, or lock-on occurs with the difference between the klystron and magnetron frequencies outside the limit of 30 ± 1 MHz.

(19) Loosen the setscrew which locks the position of the afc attenuator (fig. 3-50) and adjust the afc attenuator until klystron V902 is locked on with its frequency 30 ± 1 MHz above the magnetron frequency. Tighten the setscrew to lock the afc attenuator in this position.

WARNING

The klystron shell is at +270 volts with respect to ground. Be careful when working with the setscrew and the afc attenuator; do not make contact with the klystron shell.

(20) Using the klystron tuning tool, slightly adjust the klystron tuning knob until a maximum reading is obtained on the milliammeter.

(21) Record the value of the voltage at jack J604 of the audio unit and then set AFC/MFC switch S601 at MFC.

(22) Adjust potentiometer R632 on the audio unit to obtain the same voltage at jack J604 as was recorded in (21) above.

(23) Set the POWER switch on the control panel at STANDBY, wait 5 seconds, and return the POWER switch to the TRANSMIT position. Correct lock-on should occur within 5 seconds after the POWER switch is returned to TRANSMIT.

(24) Repeat (23) above with VOLTAGE ADJ. switch S102 on the control panel one setting above its normal position. The measured input should be 27 volts at top position No. 3.

(25) Repeat (23) above with VOLTAGE ADJ. switch S102 one setting below its normal position. The measured input should be 22.5 volts at tap position No. 3.

(26) Remove the cover from the MAG. TUNER access hole in the receiver-transmitter housing, and rotate the MAG. TUNER (fig. 350) to its extreme clockwise position. Repeat (23) through (25) above.

(27) Rotate the MAG. TUNER to its extreme counterclockwise position. Repeat (23) through (25) above. Replace the cover over the MAG. TUNER access hole.

(28) If proper lock-on does not occur in any one of the procedures in (23) through (27) above, perform (19) above; being careful to maintain a difference frequency of 30 ± 1 MHz. Check the new adjustment by performing (23) through (27) above.

(29) If lock-on at the image frequency is being obtained, rotate potentiometer R632 on the audio unit (fig. 3-58) clockwise one-half revolution and perform (23) above. Repeat this pro-

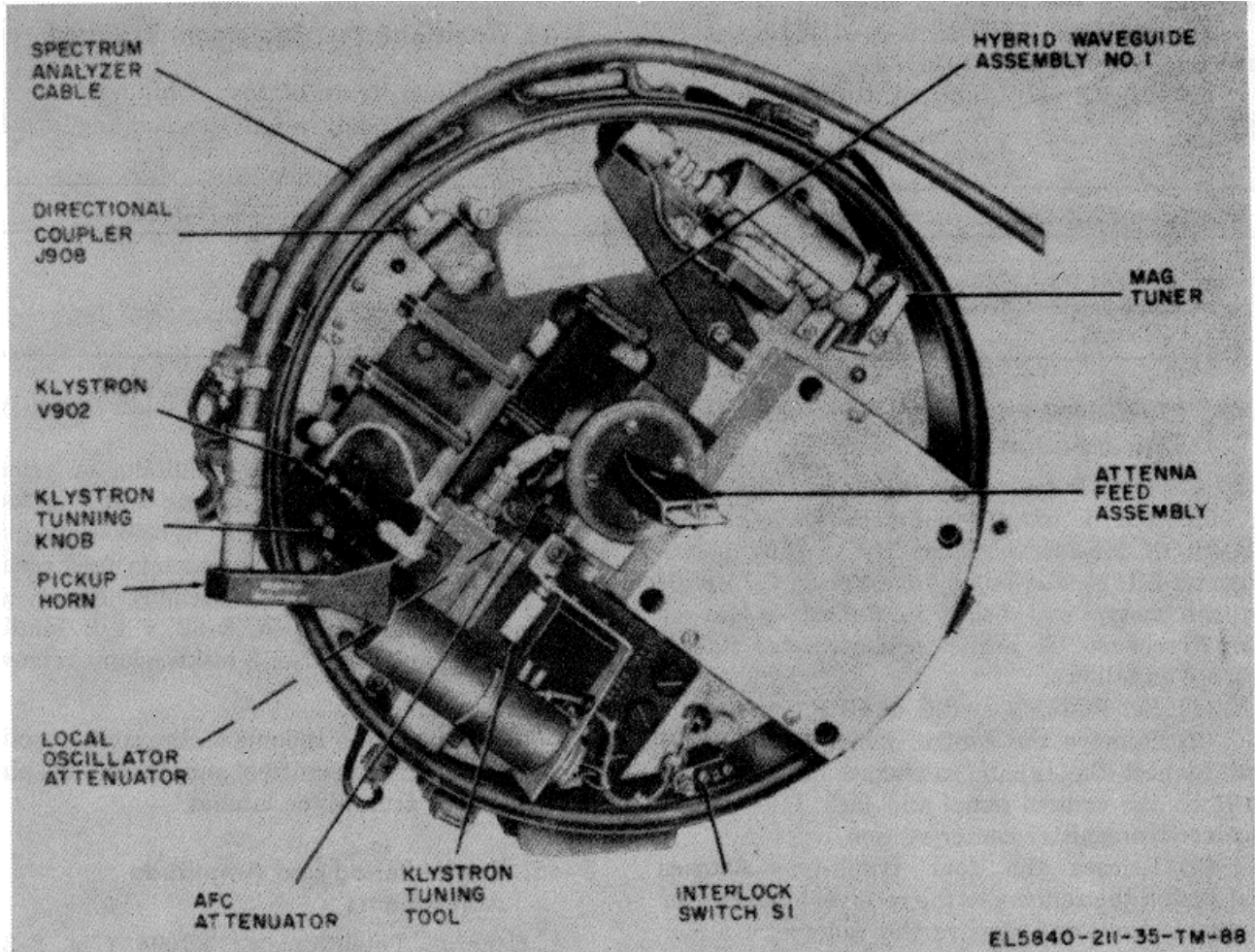

Figure 3-50. Position of spectrum analyzer pickup horn for afc adjustments.

cedure until lock-on at the image frequency is eliminated.

NOTE

The clockwise rotation of potentiometer R632 increases the frequency at which the afc sweep begins and this prevents klystron V902 from being swept through the image frequency.

(30) Set the POWER switch at OFF. Deenergize all test equipment. Remove the spectrum analyzer pickup horn and the repair patchcord. Remove the dummy antenna and replace the antenna feed assembly. Replace the control panel and radome on the receiver-transmitter housing and secure the trunk-type latches.

3-42. Adjustment and Alignment of the Ranging System

a. Paragraphs 3-44 and 3-45 cover the adjustment and alignment of the ranging system. The

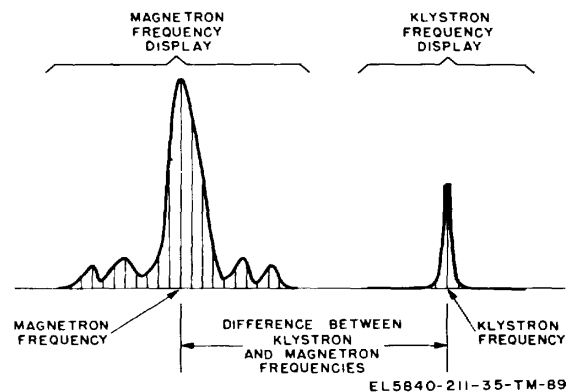

Figure 3-51. Frequency spectrum display.

complete adjustment and alignment of the radar set is described in paragraphs 3-48 through 352.

b. The ranging system adjustments should be performed in the following order:

- (1) RANGE EXTENSION METERS meter zero adjustment (para 3-44).
- (2) Strobe amplitude adjustment (para 3-45).

(3) Strobe period adjustment (para 3-45).

3-43. Tools and Test Equipment Required

The following items of test equipment are required to completely align the ranging system.

Test equipment	Functional name	Technical manual or operating parameters
Stopwatch	Stopwatch	
Dummy Antenna DA-146/U	Dummy antenna	
Control Panel Support Fixture	Support fixture.....	Para 3-14
Repair Patchcord	Repair patchcord	Para 3-14

3-44. RANGE EXTENSION METERS Meter Zero Adjustment

a. *General.* Potentiometer R1025 (fig. 3-34) is connected in parallel with the RANGE EXTENSION METERS meter. By varying potentiometer R1025, the point from which the needle on the meter will begin to deflect is varied.

b. *Procedure.* To adjust potentiometer R1025, proceed as follows: (1) Set POWER switch at OFF.

(2) Remove the control panel (para 3-59) and connect the repair patchcord between plug P101 on the control panel and jack J101 on the receiver-transmitter center section.

(3) Release the four trunk-type latches that fasten the radome to the receiver-transmitter center section, and remove the radome.

(4) Disable interlock switch S'1 by pulling the interlock shaft to the full forward position. Refer to warning notice stated in paragraph 37.

(5) Remove the antenna feed assembly from hybrid waveguide assembly No. 1 by removing the four binding head screws and four lockwashers from the antenna feed assembly flange.

(6) Secure a dummy antenna to the flange of hybrid waveguide assembly No. 1 with the four No. 8-32 x 1/2 binding head screws and four No. 8 lockwashers removed in (5) above.

(7) Set the POWER switch at TRANSMIT.

(8) Set the RANGE METERS indicator between 3,000 and 4,000 meters and place the STROBE switch at LONG.

(9) Adjust potentiometer R1025 until the needle on the RANGE EXTENSION METERS meter starts from zero at the beginning of each strobe.

(10) Set the POWER switch at OFF.

(11) Remove the repair patchcord. Replace the control panel on the receiver-transmitter

center section and fasten with four trunk-type latches.

(12) Remove the dummy antenna by removing the four binding head screws and four lockwashers from the flange of hybrid waveguide assembly No. 1. Replace the antenna feed assembly on hybrid waveguide assembly No. 1 and fasten with the four No. 8-32 x 1/2 binding head screws and four No. 8 lockwashers removed above.

(13) Replace the radome on the center section of the receiver-transmitter and fasten in place c with the four trunk-type latches.

3-45. Strobe Period and Amplitude Adjustments

a. *General.* Potentiometer R1004 (fig. 3-34) regulates the periods of both the long and short strobes. Therefore, by varying this potentiometer to adjust the long strobe period, the short strobe period will be adjusted at the same time. Potentiometer R'1017 adjusts the amplitude of both the long and short strobes.

b. *Procedure.* To adjust periods and amplitude, proceed as follows:

(1) Set the POWER switch at OFF.

(2) Perform steps (1) through (7) of paragraph 3-44.

(3) Set the STROBE switch at LONG.

(4) Using a screwdriver, adjust potentiometer R1004 until the needle on the RANGE EXTENSION METERS meter moves between 0 and 500 +10 meters in 10 +0.5 seconds, as timed by the stopwatch.

(5) Using a screwdriver, adjust potentiometer R1017 until the needle on the RANGE EXTENSION METERS meter moves at a constant rate between 0 and 500 +10 meters.

(6) Proceed as directed in paragraph 3-44b (10) through (13).

3-46. Adjustment and Alignment of the Automatic Gain Control System

a. The threshold level adjustment of system is performed in conjunction with complete system adjustment and alignment procedures.

b. Test equipment required to align the age system is listed in the following chart:

Test equipment	Functional name	Technical manual or operating parameters
Oscilloscope, AN/U'SLM-281	Oscilloscope	
Plugs for Tip Jacks	Tip jack plugs	Para 3-14
Repair Patch Cord	Repair patchcord	Para 3-14
Test Set TS-'147D/UP	Radar test set	TM 11-1247B
Control Panel Support Fixture	Support fixture.....	Para 3-14

c. Tool Equipment TE-113 is required to align the age system.

3-47. Adjustment and Alignment of the Power Converter System There is only one alignment to be made in the power converter system. This alignment concerns the RANGE EXTENSION MIETERS meter calibration for battery test, and is described in paragraph 3-28.

3-48. Complete Alignment Procedure

The following chart lists the alignment and adjustment procedures that should be performed to completely align Radar Set AN/PPS-4A. Step-by-step directions for performing the procedure listed in the alignment or adjustment column are contained in the paragraphs listed in the procedure column. To completely align the set, perform the procedures in the order listed below.

NOTE

The dummy antenna must be installed on the radar set before it can be completely aligned. Follow the procedures in paragraph 341 to replace the antenna feed assembly with the dummy antenna. Leave the dummy antenna on the radar set for all the procedures of the complete alignment.

<i>Alignment or adjustment</i>	<i>Procedure</i>
RANGE EXTENSION METERS meter..... calibration battery test.	Para 3-48
Control presetting adjustment	Para 3-49
Afc system alignments and adjustments ..	Para 3-48
Duty cycle adjustment.....	Para 3-50
Receiver threshold adjustment	Para 3-51
RANGE EXTENSION METERS meter..... zero adjustment.	Para 3-44
Strobe period and amplitude adjustments	Para 3-45
Range linearity adjustment	Para 3-29
Range calibration adjustment	Para 3-52
Power converter dc voltage output	Para 3-28
adjustment	

3-49. Control Presetting Adjustment

a. *General.* Before the complete alignment procedure can be continued, the procedures in b below must be followed to preset the controls.

b. *Procedure.*

(1) Make the controls accessible for adjustment by performing procedures in paragraph 328 b (1), (2), (3), and (5).

(2) Connect the probe of an oscilloscope (AN/USMI-281) to jack J(103 (fig. 3-32) on the range unit using a tip jack plug. Use the output at jack J401 of the range unit as an external trigger for synchronizing the oscilloscope to the radar set.

(3) Turn R615 on the audio unit (fig. 324) in a counterclockwise direction until clicks are heard.

(4) Adjust the VOLUMIE control, R105, on the control panel so that the noise level on the oscilloscope is approximately 1 volt peak-to peak.

3-50. Duty Cycle Adjustment

a. *General.* The duty of the radar set is a quantity which depends upon the pulse width and pulse repetition frequency of the magnetron pulses.

b. *Procedure.*

(1) Check the magnetron pulse width (para 3-32) and record the observed value.

(2) Calculate the required time between pulses to obtain the desired duty cycle of 0.0006. The correct time between pulses in microseconds is determined by dividing the pulse width in microseconds as determined in (1) above, by the desired duty cycle (0.0006).

(3) Perform the repetition rate adjustment (para 332), so that the time between pulses is as calculated in (2) above.

(4) Perform the power output adjustment (para 332).

NOTE

After the power output is adjusted, (1) through (3) above must be repeated to check that the desired duty cycle is still present.

3-51. Receiver Threshold Adjustment

a. General. The threshold potentiometer R615 in the audio unit (fig. 3-24) is adjusted so that the desired signal amplitude is obtained when a just saturated test signal is being fully gated.

b. Procedure.

(1) Make the radar set accessible for the receiver threshold adjustment by performing procedures in paragraph 3-28 *b* (1), (2), (3), and (5).

(2) Connect the probe of an Oscilloscope, AN/USM-281, to jack J403 (fig. 332) on the range unit using a tip jack plug. Use the Output at jack J401 of the range unit as an external trigger for synchronizing the oscilloscope to the radar set.

(3) Turn the RANGE CONTROL handwheel until a reading of greater than 3,000 meters is obtained on the RANGE METERS indicator.

(4) Remove the oscilloscope probe from jack J403 on the range unit and ground it to establish a ground reference on the oscilloscope.

(5) Return the probe to jack J403 of the range unit, and set the oscilloscope input control for ac input.

(6) Adjust the VOLUME control on the control panel until the baseline of the noise wave form on the oscilloscope is 0.75 volt above the ground reference.

(7) Remove the cover plate from the directional coupler access hole (fig. 3-63) in the receiver-transmitter housing, and unscrew the cap which fits over the directional coupler cable assembly.

(8) Connect the output cable of the * TS-147D/UP radar test set to directional coupler cable assembly jack J908.

(9) Adjust the Generator, Pulse SG-366/U output signal so that it is delayed by more than 3,000 meters, and adjust TS-147D/UP radar test set output control for a just-saturating signal, as observed on the oscilloscope.

(10) Adjust the RANGE CONTROL handwheel until the range gate is coincident with the * TS-147D/AP radar test set signal, as observed on the oscilloscope. This adjustment gates the signal from the spectrum analyzer.

(11) Adjust potentiometer R615 (fig. 3-24) on the audio unit until the amplitude of the signal is

reduced to 1.5 +0.2 volt peak-to-peak. While R615 is being adjusted, occasionally rock the RANGE CONTROL handwheel to insure that the target is being fully gated.

3-52. Range Calibration Adjustment

a. General. Perform the range calibration adjustment whenever components have been replaced in the range unit. Check that the control panel is fastened to the center section of the receiver-transmitter. Before the range calibration adjustment is performed, make certain that the range linearity adjustment (para 3-29) has been completed.

b. Procedure. To perform the range calibration adjustment, proceed as follows: (1) Set the POWER switch at OFF.

(2) Set the VOLUME control fully clockwise.

(3) Remove the cover plate from the directional coupler access hole on the receiver-transmitter center section (fig. 3-63).

(4) Unscrew the cap from the directional coupler cable assembly (fig. 3-71).

(5) Connect Range Calibrator AN/UPM-11A range calibrator rf cable to directional coupler jack J908 in the access hole.

(6) Set the POWER switch at RANGE.

Allow the radar and the range calibrator to warm up continuously for at least 2 hours before proceeding to the steps below.

(7) Set the POWER switch at TRANSMIT; tune the range calibrator and lock-on afc according to instructions given in TM 11-6625-310-15 to give responses at the transmitter frequency of the radar.

(8) Set the POWER switch at RANGE.

(9) Set the RANGE METERS indicator at 500 meters. Adjust the RANGE CALIBRATION 1st MARK control to obtain a minimum deflection on the RANGE EXTENSION METERS meter.

NOTE

More than one deflection may occur. Select the minimum deflection.

(10) Set the RANGE METERS indicator at 3,500 meters. Adjust the RANGE CALIBRATION 7th MARK control to obtain a minimum deflection on the RANGE EXTENSION METERS meter.

(11) Set the RANGE METERS indicator at 6,500 meters. Adjust RANGE CALIBRATION 7th MARK control to obtain a minimum deflec-

tion on the RANGE EXTENSION METERS meter.

NOTE

A minimum deflection may occur at two positions of the RANGE CALIBRATION 7th MARK control. The correct position is that which requires the least movement of the RANGE CALIBRATION 7th MARK control from the final position ((9) above).

(12) Adjust the RANGE CONTROL handwheel to obtain a minimum deflection of the RANGE EXTENSION METERS meter between the ranges of 3,450 and 3,550 meters as indicated on the RANGE METERS indicator. If a minimum deflection cannot be obtained between these ranges, repeat (9) through (12) above.

(13) Set the POWER switch at TRANSMIT.

(14) Set the RANGE METERS indicator at the value of the signal generator range mark nearest 500 meters. (Calculate the range calibrator rangemarks as directed in TM 11-662531015). Adjust the RANGE CALIBRATION 1st MARK control to obtain a minimum deflection on the RANGE EXTENSION METERS meter.

(15) Set the RANGE METERS indicator at the value of the range calibrator range mark nearest 6,500 meters. Adjust the RANGE CALIBRATION 7th MARK control to obtain a minimum deflection on the RANGE EXTENSION METERS meter.

(16) Repeat (14) and (15) above until the minimum deflection of the meter is obtained within +5 meters of the range calibrator rangemark used in each step.

(17) Using the range calibrator rangemarks, check the accuracy of the ranging system by adjusting the RANGE CONTROL handwheel to obtain a minimum deflection on meter M101 at the approximate value of each signal generator rangemark. Tabulate each range calibrator rangemark and the indication on the RANGE METERS indicator at which the minimum deflection was obtained for that rangemark. Complete this step within 10 minutes.

(18) Plot the deviation of the values tabulated in (17) above from the actual range calibrator rangemarks versus the range calibrator rangemarks as demonstrated in figure 3-52. Positive deviation occurs when the values on the RANGE METERS indicator is higher than the value of the range calibrator rangemark. Determine and plot the best straight line that will minimize peak error as instructed in c below.

(19) Tabulate the following values:

- a = Range dial deviation at the range calibrator rangemark nearest 500 meters as determined in (17) and (18) above.
- b = Value of the straight line, plotted in c below, at the range calibrator rangemark nearest 500 meters.
- c = Range dial deviation at the range calibrator rangemark nearest 6,500 meters as determined in (17) and (18) above.
- d = Value of the straight line, plotted in c below, at the range calibrator rangemark nearest 6,500 meters.

(20) Set the RANGE METERS indicator at the value equal to--(the range calibrator rangemark nearest 500 meters) +a -b.

(21) Adjust RANGE CALIBRATION 1st MARK control for a minimum deflection on meter M101.

(22) Set the RANGE METERS indicator at the value equal to: (the range calibrator rangemark 6,500 meters) + c -d.

(23) Adjust the RANGE CALIBRATION 7th MARK control for a minimum deflection on meter M101.

(24) Repeat (20), (21), (22), and (23) above until the minimum deflection on meter M101 is obtained within +2 meters of the values used in (20) and (22) above.

NOTE

Steps (25) and (26) below must be completed within 5 minutes of step (24) above.

(25) Set the POWER switch at RANGE.

(26) Record the value nearest 500 meters on the RANGE METERS indicator at which the minimum deflection is obtained on meter M101. Record the value nearest 6,500 meters on the RANGE METERS indicator at which the minimum deflection is obtained on meter M101. Repeat this procedure several times to insure proper accuracy.

(27) Record the prevailing room temperature during (26) above within +2 degrees F.

(28) Set the POWER switch at TRANSMIT.

(29) Check the accuracy of the ranging system by repeating (17) and (18) above. If the best straight line is within +8 meters of the zero meter line on the graph, the values determined in (25) above are the nominal calibration figures. If the straight line is not within +3 meters, repeat (17) through (27) above.

(30) The RANGE METERS indication for the list MARK determined in (26) above, is the 1st MARK calibration figure. Write this value on the RANGE CALIBRATION plate.

(31) The 7th MARK calibration figure for 50 to 100 degrees F is equal to the 7th MAR value obtained in (26) above plus 0.3 times the temperature noted in (27) above minus 7 Round this figure off to the nearest meter and write it on the RANGE CALIBRATION plate.

(32) The additional calibration figure for the 7th MARK are calculated as follows:

(a) Over 100 degrees F: (50 to 100 degree F calibration figure) plus 15 meters.

(b) 0 to 50 degrees F: (50 to 100 degree F calibration figure) minus 15 meters.

(c) Below 0 degrees F: (50 to 100 degree F calibration figure) minus 28 meters.

(33) Set the POWER switch at OFF.

(34) Deenergize the range calibrator.

(35) Remove the range calibrator RF cable from jack J908.

(36) Replace the cap on the directional coupler cable assembly and replace the cover plate on the directional coupler access hole.

c. *Straight Line Plotting.* To plot the best straight line as required in b (18) above, proceed as follows:

(1) Employing the same scale used in plotting deviation versus signal generator rangemarks in b (18) above, mark a transparent overlay of plastic, vellum, or other suitable material as indicated in figure 3-53. Punch a small hole in the overlay at the places designated as 0 in figure 3-53.

(2) Position the overlay over the graph of deviation versus signal generator rangemarks plotted in b (18) above. Adjust the overlay as indicated in figure 3-54 so that the zero meter line of the overlay is near the zero meter line of the graph, and so that $w = v$ and $x = y$.

(3) Mark two points through the two holes on the overlay and draw a line between these

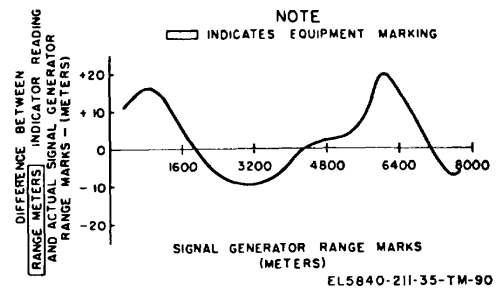

Figure 3-52. Deviation versus signal generator rangemarks.

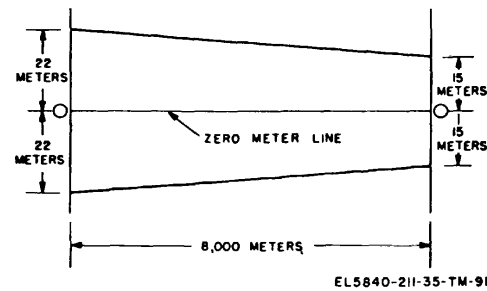

Figure 3-53. Overlay used in plotting straight line.

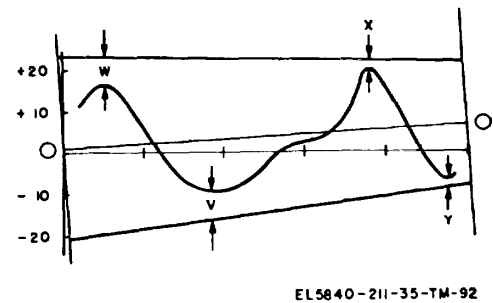

Figure 3-54. Positioning overlay.

points on the graph. This line will be the best straight line that will minimize peak error.

Section IV. REPAIR

3-53. Repair of Radar Set AN/PPS-4A

Direct support repair of Radar Set AN/PPS-4A consists of removal and replacement of defective units or components as described in section V and repair of the items listed below. All other repairs will be referred to higher category of maintenance.

- a. Cable Assembly, Special Purpose CX-4934/U (para 3-54).
- b. Cable Assembly, Special Purpose CX-4935/U (para 3-54).
- c. Headset, Electrical H-183/PPS-4 (para 3-55).
- d. Case, Receiver-Transmitter CY-2733/PPS-4 (para 3-56).

- e. Strobe unit (para 57).
- f. Microwave unit (para 358).

3-54. Repair of Special Purpose Cables

Repair of the special purpose cables consists of removing and replacing damaged connectors. Damaged connectors may be unscrewed and pulled back. Disconnect defective connectors from cable using a soldering iron. Refer damaged cables to higher category of maintenance for repair.

3-55. Repair of Headset

Repair of Headset, Electrical H-183/PPS-4 consists of repair of damaged clothespin, repair of loose cable connections in the earphones; and replacement of damaged connectors (para 364).

3-56. Repair of Case, Receiver Transmitter CY-2733/PPS-4

Repair of Case, Receiver-Transmitter CY-2733/ PPS-4 consists of repair or replacement of damaged trunk-type latches, carrying handles, telescope bracket and clip, two telescope light cable clips, running spares bracket and clips, four brackets for the cable wrap, elastic cord

used to hold the technical manual in place, two rubber rings, and six rubber bumpers. After replacement of rubber rings, check to see that the case is watertight and that it will float.

3-57. Repair of Strobe Unit Repair of the strobe unit consists of removal and replacement of all defective components mounted on the strobe unit circuit board with exception of transistors. All transistors are checked, removed, and replaced at higher category of maintenance.

3-58. Repair of the Microwave Unit Direct support repair of the microwave assembly consists of removal and replacement of the entire assembly from the receiver-transmitter center section, removal and replacement of defective assembly components, complete disassembly and reassembly of the unit, cleaning (para 3-67), and complete adjustment and alignment of the unit. The adjustment and alignment procedures for the microwave unit are contained in the 'adjustment and alignment procedures for the transmitting system (para -30) and the receiving system (para 3-34).

Section V. REMOVAL AND REPLACEMENT

CAUTION

Direct support maintenance personnel are not authorized to remove or replace components other than those described in this section.

3-59. Control Panel and Radome

a. *Removal.*

(1) Make sure that POWER switch S101 is set at OFF.

(2) Release the four trunk-type latches that fasten the control panel on the receiver-transmitter. Remove the control panel. Care should be taken in handling the control panel to prevent damage to meter M101, the strobe unit, and exposed soldered connections.

NOTE

Jack J101 on the receiver-transmitter and plug P101 on the control panel are separated when the control panel is removed.

(3) Set the control panel in an upright position and secure it in place with the control panel support fixture (fig. 3-5)

hold the technical manual in place, two rubber rings, and six rubber bumpers. After replacement of rubber rings, check to see that the case is watertight and that it will float.

(4) Release the four trunk-type latches that fasten the radome to the receiver-transmitter.

Remove the radome. Care should be taken to prevent denting the reflector or damaging the dipole of the antenna feed.

b. *Replacement.*

(1) Remove the control panel from the control panel support fixture (fig. 3-5). Install the control panel on the receiver-transmitter center section. Fasten the four trunk-type latches to secure the control panel in place.

(2) Install the radome on the receiver-transmitter center section. Fasten the four trunk-type latches to secure the radome in place.

3-60. Strobe Unit (fig. 3-8)

a. *Removal.*

(1) Remove control panel and radome (para 3-59).

(2) Remove four binding head screws.

(3) Disconnect jack J105 from plug P105 by loosening two knurled captive screws.

(4) Remove the strobe unit from rear of control panel.

b. Replacement.

- (1) Align the strobe unit on rear of control panel.
- (2) Connect jack J105 to plug P105.
- (3) Install four binding head screws.
- (4) Replace control panel and radome (para 3-59).

3-61. Transmitter, Radar T-967/PPS 4A

WARNING

Extremely dangerous voltages exist in the transmitting system. Be sure that POWER switch S101 is in the OFF position.

- (1) Remove the control panel and radome (para 3-59).
- (2) Disable interlock switch S1 (fig. 3-1) by pulling the interlock shaft to the full forward position. Interlock switch S1 opens when the radome is pulled approximately 1 inch from the receiver-transmitter center section. When open, the interlock switch disconnects the +24-volt external power source output from the power converter system.

WARNING

The primary function of the interlock switch is to protect personnel against injury from voltages greater than 500 volts. When the interlock switch is disabled, observe the precautions listed in paragraph 3-7.

- (3) Disconnect plug P201 of the transmitter unit from jack J201 (fig. 3-60) on the mounting plate.
- (4) Remove the magnetron connector clamp by removing the two binding head screws which hold the clamp in place (fig. 3-63).
- (5) Disconnect coaxial cable BNC connector P901 from jack J901 (fig. 3-63) on the magnetron. Disconnect coaxial cable plug P508 of the IF amplifier unit from jack J206 (fig. 3-12) of the transmitter unit. Disconnect plug P207 from jack J207.
- (6) Remove the four binding head screws that fasten the transmitter unit to the center section of the receiver-transmitter, and one binding head screw that fastens the transmitter ground lead (fig. 3-63) on the choke joint of the microwave assembly.
- (7) Remove the transmitter unit from the receiver-transmitter.

b. Replacement.

- (1) Assemble the transmitter unit in the upper portion of the receiver-transmitter center section. Secure the transmitter unit in place with four No. 632 x 1/4 binding head screws. Connect the transmitter ground lead (fig. 3-12) to the choke joint on the microwave assembly (fig. 3-63) with one No. 8-32 x 3/8 binding head, screw and one No. 8 lockwasher.
- (2) Connect coaxial cable plug P508 of the TF amplifier unit to jack J206 (fig. 3-12) of the transmitter unit. Connect coaxial cable BNC connector P901 of the transmitter unit to jack J901, (fig. 3-63) on the magnetron.
- (3) Install the magnetron connector clamp (fig. 3-63) with two No. 9032 x 1 1/2 binding head screws and two No. 10 lockwashers.
- (4) Connect plug P201 to jack J201 (fig. 3-60) on the receiver-transmitter mounting plate.
- (5) Connect plug P207 to jack J207 (fig. 3-13).
- (6) Replace the control panel and radome (para 3-9).

3-62. Range Unit MX-2924/PPS4

a. Removal.

- (1) Remove the control panel (para 3-59).
 - (2) Disconnect plug P407 from jack J407 on the side of the range unit.
 - (3) Remove plug P408 from jack J408.
 - (4) Loosen the two captive screws that fasten the range unit to the mounting plate.
 - (5) Remove the range unit from the mounting plate.
- b. Replacement.*
- (1) Place plug P401 on the range unit into jack J401 on the mounting plate.
 - (2) Secure the range unit to the mounting plate by tightening the two captive screws on the range unit.
 - (3) Connect plug P408 to jack J408 on the range unit.
 - (4) Connect plug P407 to jack J407 on the side of the range unit.
 - (5) Replace the control panel (para 3-59).

3-63. Amplifier, Intermediate Frequency AM-4175/PPS-4A

a. Removal.

- (1) Remove the control panel and radome (para 3-59).
- (2) Remove the afc unit (para 3-45).
- (3) Remove the audio unit (para 3-64).

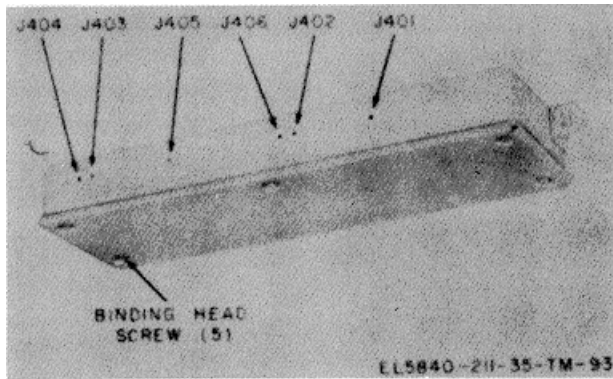

Figure 3-55. Range unit, cover attached.

(4) Remove the transmitter unit (para 361).
 (5) Remove the range unit (para 3-62).

(6) Disconnect the two coaxial cables from jacks J906 and J906 (fig. 3-64) on hybrid waveguide assembly No. 2 (fig. 3-1).

(7) Disconnect the blanking pulse cable from jack J206 on the transmitter unit (fig. 312).

(8) Disconnect plug P502 from jack J502 on the IF amplifier unit (fig. 3-56).

(9) Disconnect plug P501 from jack J501 on the IF amplifier unit.

(10) Loosen the four captive screws that fasten the IF amplifier unit to the center section of the receiver-transmitter and remove the IF amplifier unit.

b. Replacement.

(1) Install the IF amplifier unit on the center section of the receiver-transmitter and tighten the four captive screws that fasten the IF amplifier unit to the center section mounting plate.

(2) Connect plug P501 to jack J501 on the IF amplifier unit.

(3) Connect plug P502 to jack J502 on the IF amplifier unit.

(4) Connect the blanking pulse cable (fig. 3-57) attached to the blanking pulse subchassis to jack J206 on the transmitter unit (fig. 3-12).

(5) Connect plugs P504 and P505 at the ends of the coaxial cables attached to the IF amplifier unit to jacks J905 and J906 (fig. 3-64) respectively on hybrid waveguide assembly No. 2 (fig. 3-1).

(6) Install the audio unit (para 3-64).

(7) Install the afc unit (para 3-65).

(8) Install the transmitter unit (para 3-61).

(9) Install the range unit (para 3-62).

(10) Install the control panel and radome (para 3-59).

3-64. Audio Unit MX-2925/PPS-4

a. Removal.

(1) Remove the control panel (para 3-59).

(2) Loosen the two captive screws that fasten the audio unit to the mounting plate of the receiver-transmitter center section (fig. 313).

(3) Remove the audio unit.

b. Replacement.

(1) Install the audio unit in the receiver-transmitter center section (fig. 3-13).

(2) Tighten the two captive screws that fasten the audio unit to the mounting plate of the receiver-transmitter housing.

(3) Replace the control panel (para 3-59).

3-65. Automatic Frequency Control Unit C-3115/PPS-4

a. Removal.

(1) Remove the control panel (para 3-59).

(2) Disconnect plug P503 (fig. 3-56) from jack J702 of the afc unit (fig. 3-59).

(3) Loosen the two captive screws that fasten the afc unit to the mounting plate of the receiver-transmitter center section and remove the afc unit.

(4) Disconnect plug P703 from jack J907 on hybrid waveguide assembly No. 2 (fig. 3-74).

b. Replacement. Connect plug P703 of the afc unit to jack J907 on hybrid waveguide assembly No. 2 (fig. 3-74). Install the afc unit in the center section of the receiver-transmitter (fig. 3-13) and tighten the two captive screws on the afc unit to secure the unit to the mounting plate of the receiver-transmitter housing. Connect plug P503 of the IF amplifier unit to jack J702 on the afc unit (fig. 3-59). Replace the control panel (para 3-59).

c. Removal of afc unit cover.

(1) Remove the five binding head screws and five lockwashers that secure the cover on the afc unit, and remove the cover (fig. 3-59).

CAUTION

When performing the following disassembly procedures, use extreme care to prevent stress on the interconnecting wiring and fragile circuit board.

(2) Loosen the clamping nut that fastens jack J703 (fig. 3-22) to the chassis of the afc unit, and slide jack J703 with its attached cable from the slotted opening in the chassis.

(3) Loosen the clamping nut that fastens jack J702 to the afc unit chassis, and slide jack J702 from the slotted opening in the chassis.

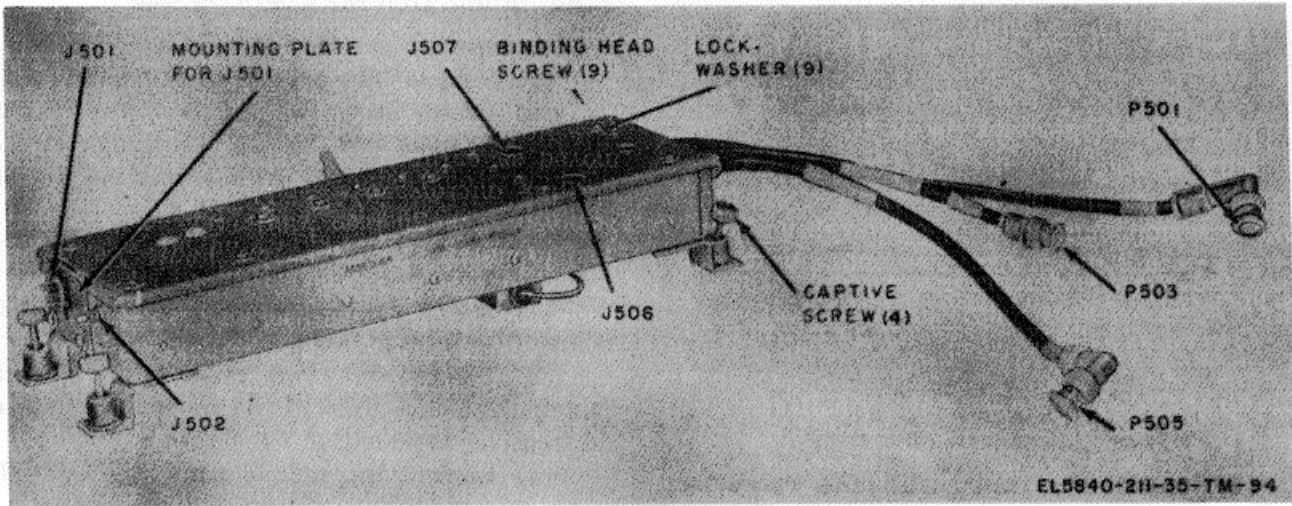

Figure 3-56. IF amplifier unit, top view.

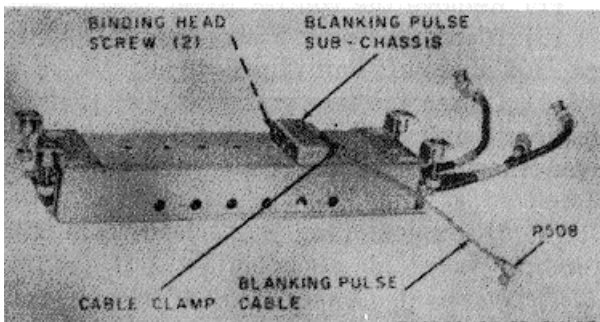

Figure 3-57. IF amplifier unit, bottom, view.

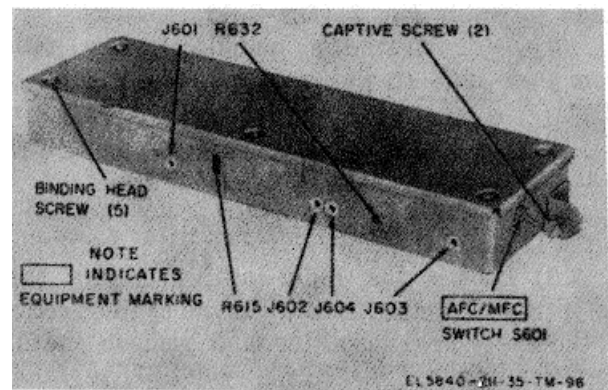

Figure 3-58. Audio unit, cover attached

(6) Assemble the cover to the afc unit and secure the cover (fig. 3-59) in place with five No. 4-40 x 5/16 binding head screws and five No. 4 lockwashers.

3-66. Power Converter CV-1803/PPS-4A

a. Removal.

WARNING

Extremely high voltages exist in the power converter system at the +300volt line.

(1) Remove the radome (para 3-59).

(2) Loosen the four captive screws that fasten the power converter to the center of the receiver-transmitter.

(3) Remove the power converter unit from the receiver-transmitter.

(4) Unscrew and remove the five standoff posts and five plain washers from the afc circuit board (fig. 3-21). Remove the two binding head screws and two plain washers that fasten plug P701 to the afc unit chassis, and lift out the afc circuit board (fig. 3-22).

d. Replacement of afc unit cover.

(1) Replace the afc circuit board in the afc unit chassis.

(2) Replace the two No. 4-40 x 5/16 binding head screws and two No. 4 plain washers that fasten plug P701 to the afc unit chassis.

(3) Replace the five standoff posts and associated No. 6 plain washers that secure the afc circuit board to the afc unit chassis.

(4) Slide the threaded portion of jack J702 into the slotted opening in the afc unit chassis and tighten the clamping nut that secures jack J702 in place.

(5) Slide the threaded portion of jack J703 into the slotted opening in the afc unit chassis and tighten the clamping nut that secures jack J703 in place.

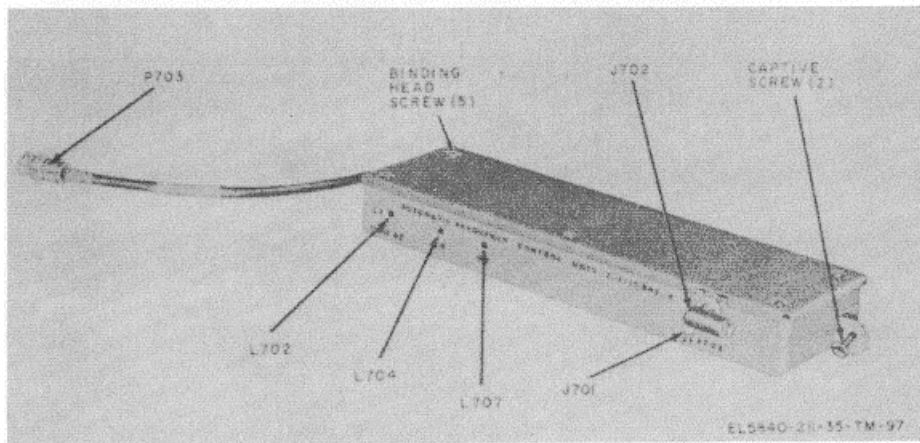

Figure 3-59. Afc unit, cover attached.

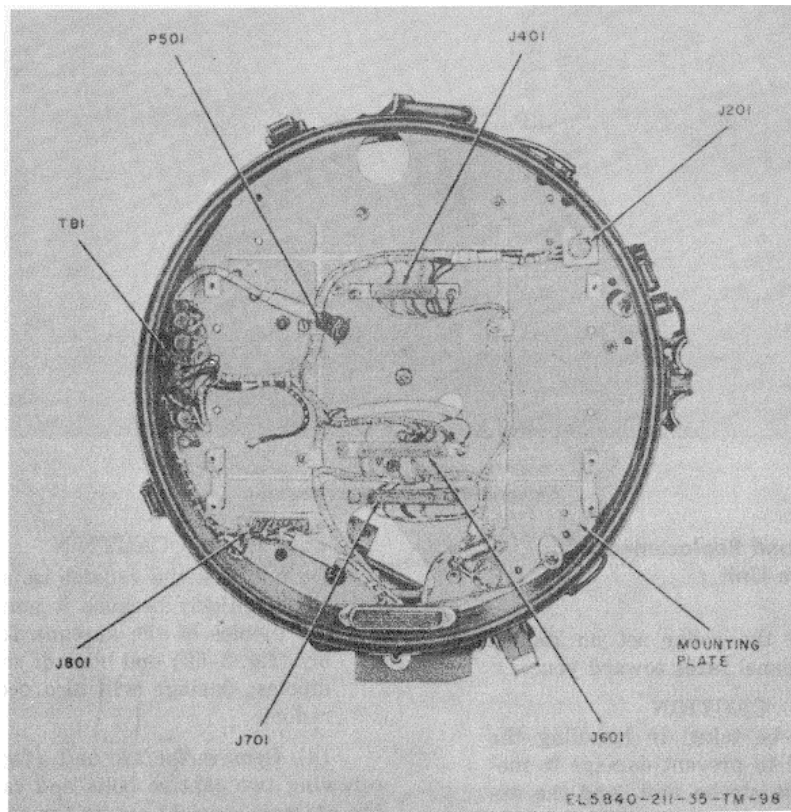

Figure 3-60. Receiver-transmitter, rear side, units removed.

b. Replacement.

(1) Align the power converter unit in the center section of the receiver-transmitter so that plug P801 mates with jack J801.

(2) Secure the power converter unit in the receiver-transmitter by tightening the four captive screws.

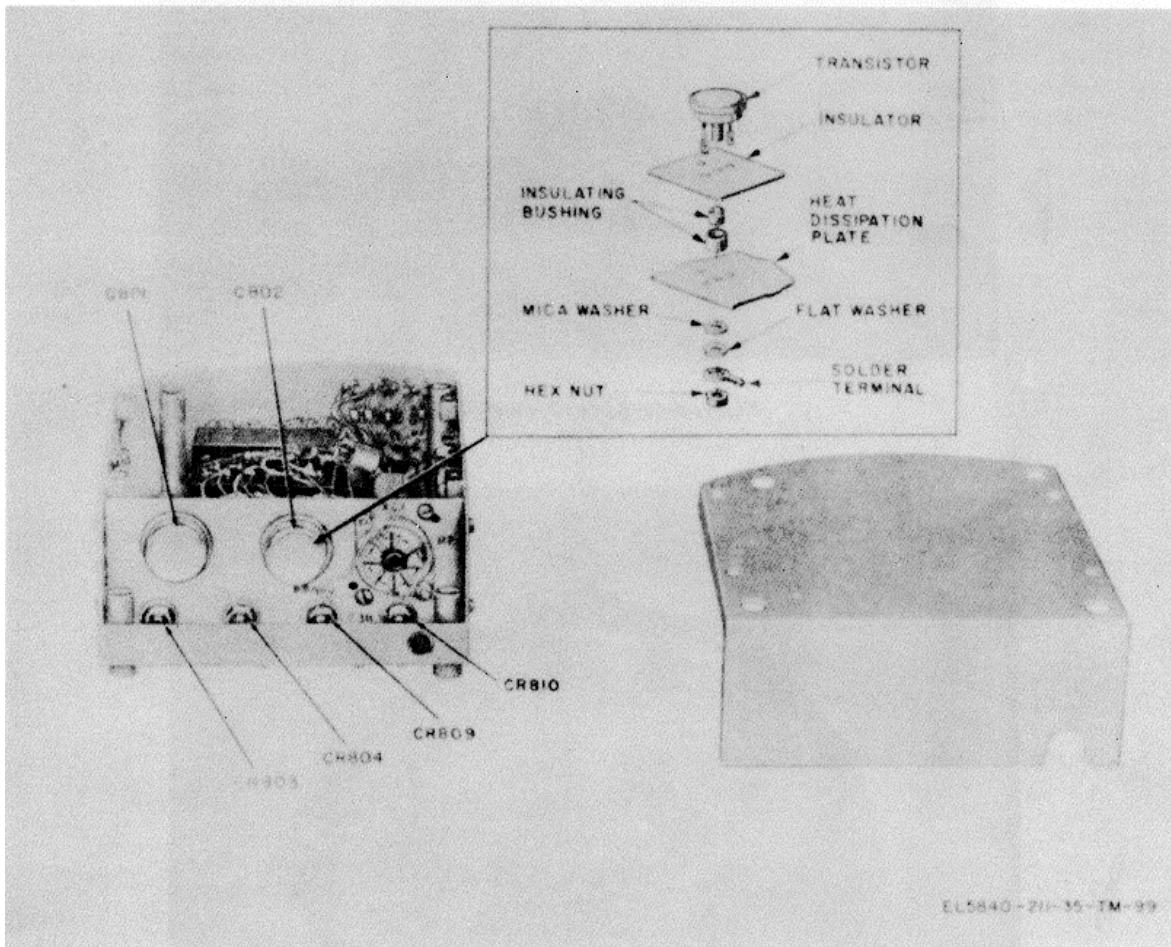

Figure 3-61. Power converter unit.

3-67. Removal and Replacement of Microwave Unit

a. Removal.

(1) Position the radar set on its side so that the control panel faces toward you.

CAUTION

Care should be taken in handling the control panel to prevent damage to meter M101, the strobe unit, and the exposed wiring.

(2) Unlatch four trunk-type latches and carefully remove the front panel.

(3) Position the radar set flat on the front panel side with the radome facing up. Unlatch four trunk-type latches, and *slowly lift the radome straight up.*

CAUTION

Do not jerk the radome up and do not lift it quickly because it may catch on the dipoles of the antenna feed assembly (fig. 3-62) and bend or snap off the dipoles; damage will also occur to the radome.

(4) Remove the afc unit (fig. 3-X13) by unscrewing two captive bolts and carefully pulling the afc unit *straight out* as far as the cables will permit.

CAUTION

The afc unit must not be twisted or turned when the unit is removed because the pins of plug P701 at the back of the afc unit may be damaged.

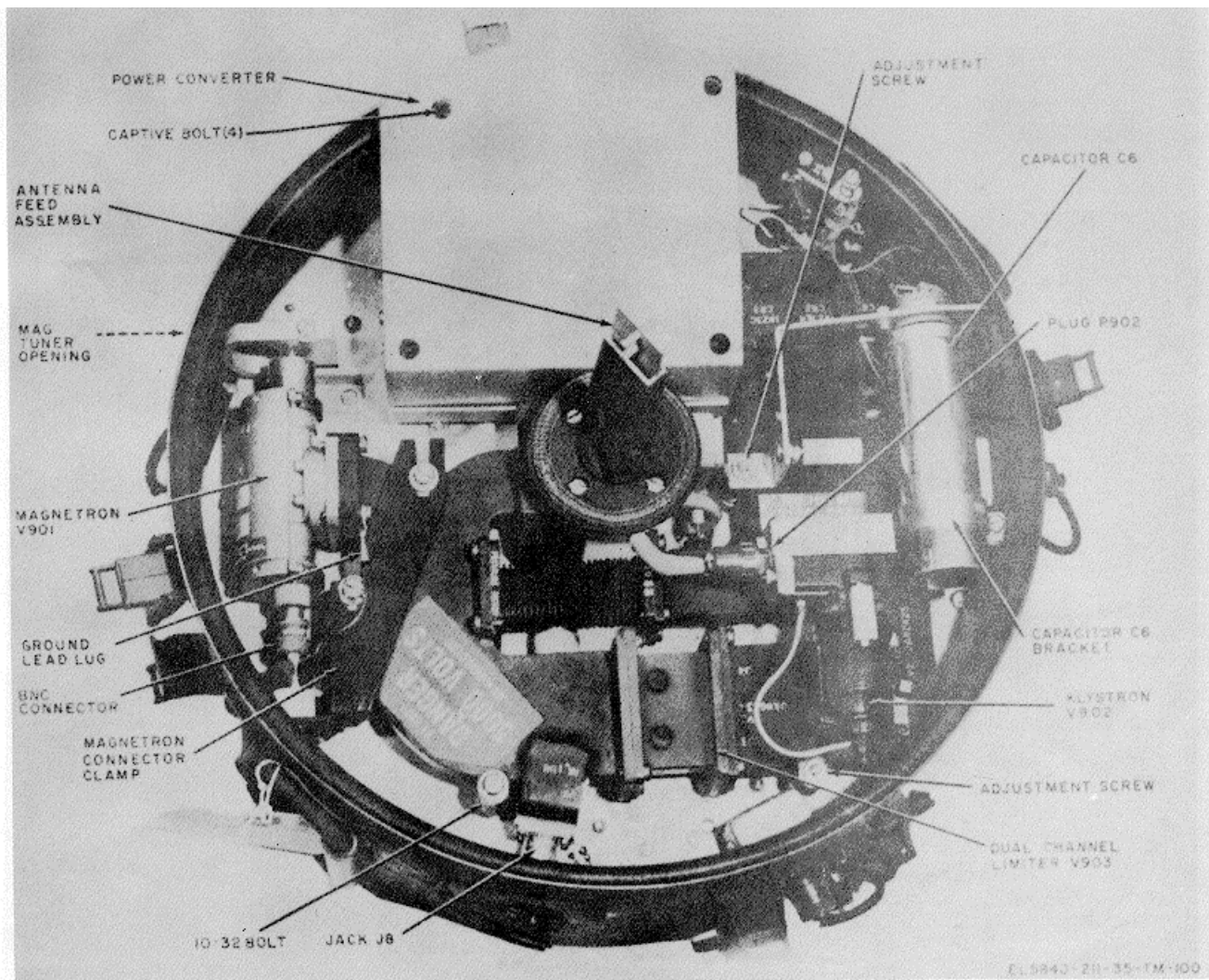

Figure 3-62. Receiver-transmitter, front side, radome removed.

(5) Remove the IF amplifier unit plug P503 from afc unit jack J702 (fig. 3-59).

(6) Before performing the procedures given here, read the caution below. Remove afc unit plug P703 from crystal jack (fig. 3-64) by using only your fingers to turn the BNC connector to the left to unlock; then pull straight out.

CAUTION

Do not use pliers. Make sure that no side pressure is applied because the crystal jacks will snap off.

(7) Remove IF amplifier unit plug P505 from crystal jack J905 (fig. 3-64).

(8) Remove IF amplifier unit plug P505 from crystal jack J906 (fig. 3-64).

(9) Remove the power converter (fig. 3-62) by unscrewing four captive screws and lifting the power converter straight out.

CAUTION

The power converter unit must not be twisted or turned when the unit is removed, because the pins of plug P801 at the back of the power converter may be damaged.

(10) Before performing the procedures given here, read the caution below. Remove capacitor C6 bracket (fig. 3-62) by unscrewing one 8-32 bolt with flat washer and lockwasher and sliding capacitor C6 bracket from capacitor C6.

CAUTION

Make sure that klystron V902 (fig. 3-62) tuning bow is not accidentally moved; if the tuning bow should turn, a complete alignment may be required.

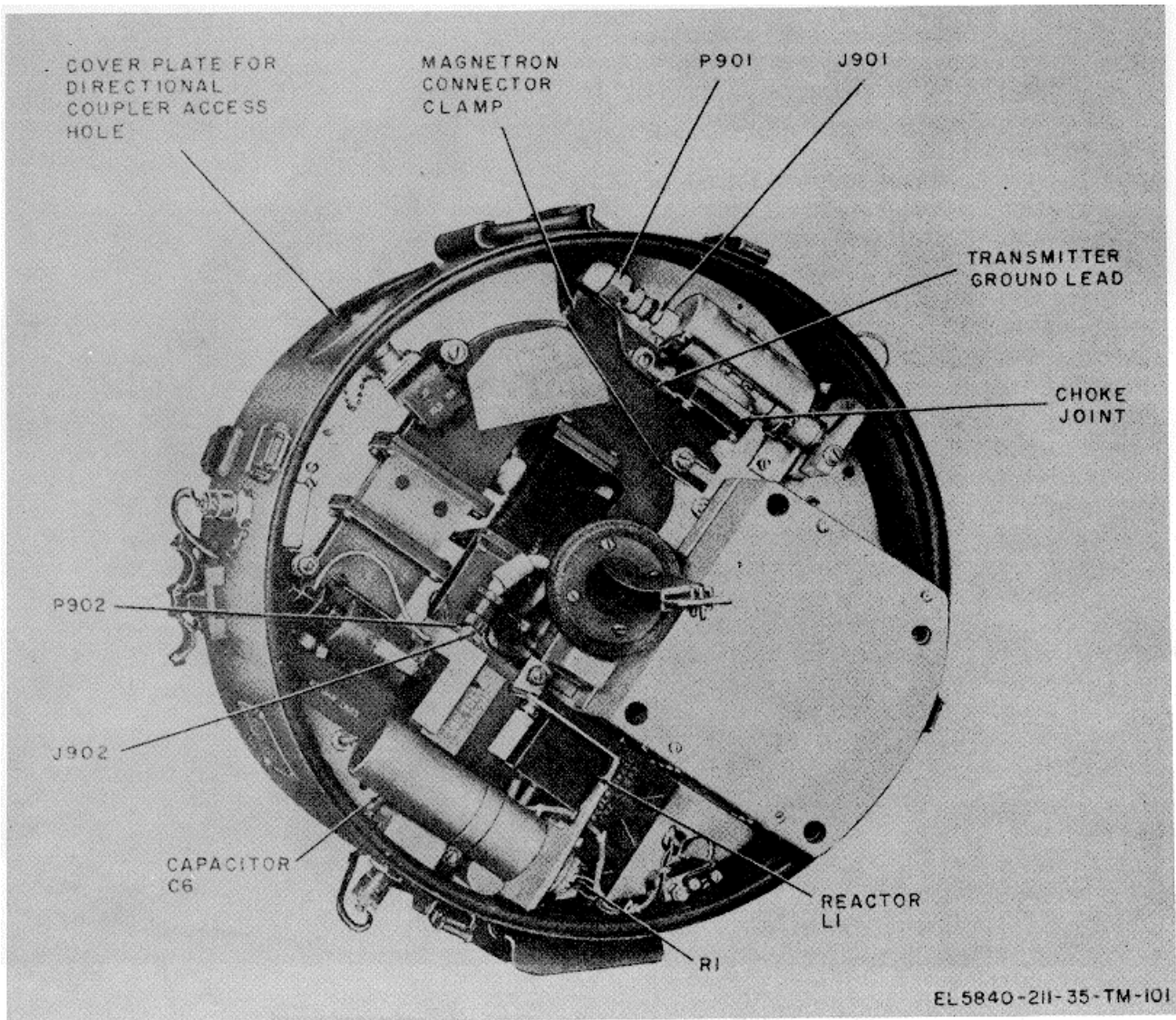

Figure 3-63. Receiver-transmitter center section, microwave assembly in place.

(11) Remove capacitor C6 from its socket.

(12) Remove capacitor C6 socket from the bracket assembly (fig. 3-65) by unscrewing two 6-32 bolts with two flat washers and two lock-washers.

(13) Locate the socket so that the adjustment screw with the 10-32 hexagonal locknut is exposed (fig. 3-65).

(14) Before performing the procedures given in this subparagraph, read the caution below. Set a 3/8-inch box wrench over the exposed 10-32 hexagonal locknut. Hold a screwdriver in a manner similar to that shown in figure 3-66 so that the adjustment screw does not turn; re- move the locknut with lockwasher.

CAUTION

Do not use an oversized screwdriver on the adjustment screw because the slot will spread, and removal of the hexagonal locknut will strip the threads on the adjustment screw. The adjustment screw must not be turned when removing the 10-32 hexagonal locknut because the seating of the waveguide assembly and the position of the antenna feed assembly dipole will change. This, in turn, will set the antenna feed assembly off the focal point and cause erroneous azimuth readings, a broad radiated beam, and a decrease in the maximum distance at which a target may be picked up.

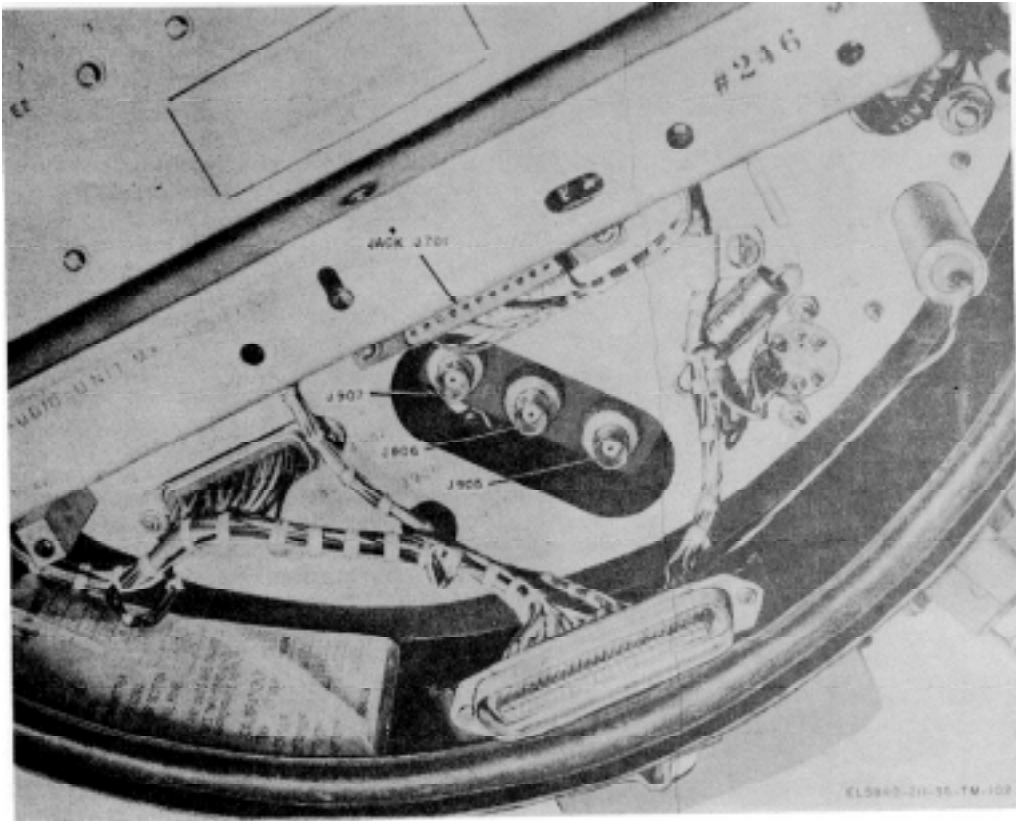

Figure 3-64. Crystal jacks and jack J701 exposed.

(15) Remove the bracket assembly (fig. 3-65) from the microwave assembly by removing the remaining 10-32 hexagonal locknut with lockwasher from the other adjustment screw which protrudes through the bracket assembly (fig. 3-66). Refer to the procedure outlined in (14) above.

(16) Remove the 10-32 hexagonal locknut, flat washer, and lockwasher from the adjustment screw under klystron V902 (fig. 3-62).

(17) Before performing the procedures given here, read the caution below. Remove plug P902 (fig. 3-62) from jack J902 by turning the knurled outer casing of plug P902 one-quarter turn to unloosen spring clamp; unlock the spring clamp and pull plug P902 straight out.

CAUTION

Do not twist or turn plug P902 because the plug pins may be damaged.

(18) Remove the 10-32 bolt with flat washer and lockwasher near jack J8 (fig. 3-62).

(19) Remove two 10-32 bolts, two flat washers, and two lockwashers from the magnetron connector clamp (fig. 3-62); remove the magnetron connector clamp.

(20) Remove the ground lead lug by unscrewing the 8-32 bolt with flat washer and split lockwasher (fig. 3-62).

(21) Remove the BNC connector from magnetron V901 by turning the BNC connector to unlock.

(22) Before performing the procedures given here, read the caution below. Hold hybrid

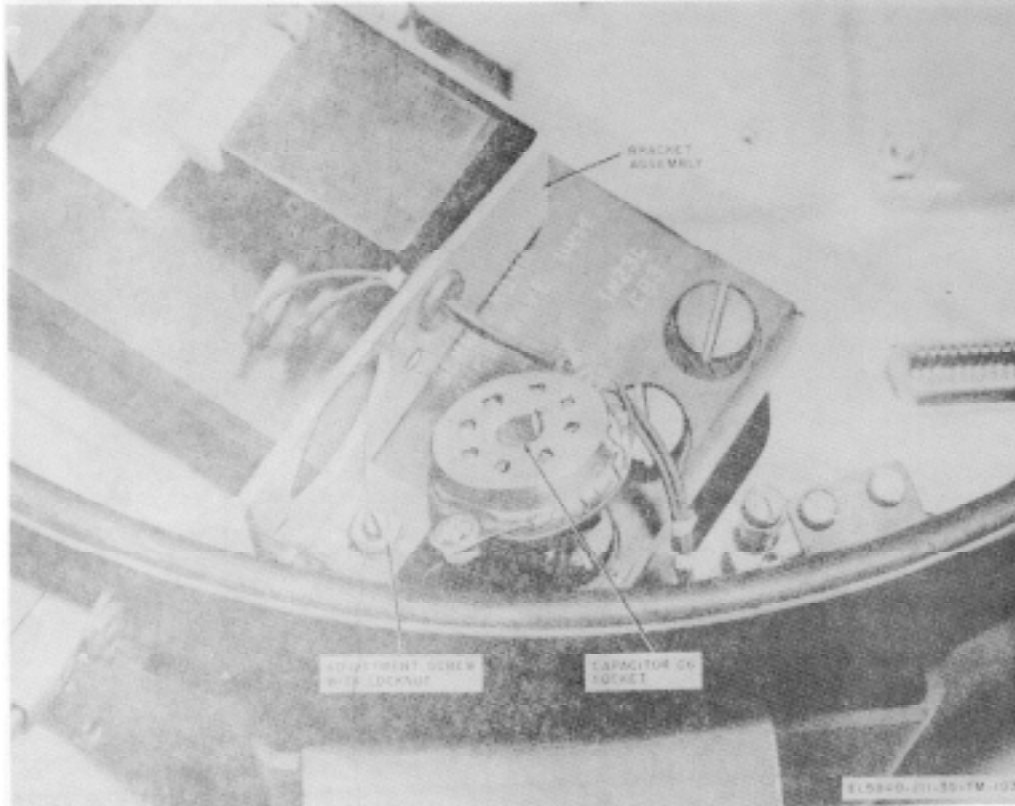

Figure 3-65. Capacitor C6 socket removed and adjustment screw with locknut exposed.

waveguide assembly No. 1) with the left hand (magnetron V901 is located on hybrid waveguide assembly No. 2 (kylstron V902 is located on hybrid waveguide assembly No. 2), just forward of kylstron V902, with the right hand. Slowly lift straight up to remove the microwave assembly from the center locating pin (fig. 3-67), tilt the microwave assembly toward the MAG Tuner opening on the center section, and slowly lift the microwave assembly out of the center section.

CAUTION

Do not force the microwave assembly. Adjustment screws, center locating pin, and magnetron knurled tuning knob may be damaged. Make sure that the magnetron knurled turning knob (fig.

3-70) does not turn; if the knob should turn, a complete alignment may be required.

b. Replacement.

(1) Before performing the procedure given here, read the note below. Make sure magnetron V901 knurled tuning knob (fig. 3-70) is positioned so that the knurled surface will be exposed through the center section AIAG TUNER opening (fig. 3-62).

NOTE

If magnetron, V901 knurled tuning knob is turned, a complete alignment may be required.

(2) Set the ground lead lug and wire against the side of the center section so that the ground lead does not interfere with the microwave assembly placement.

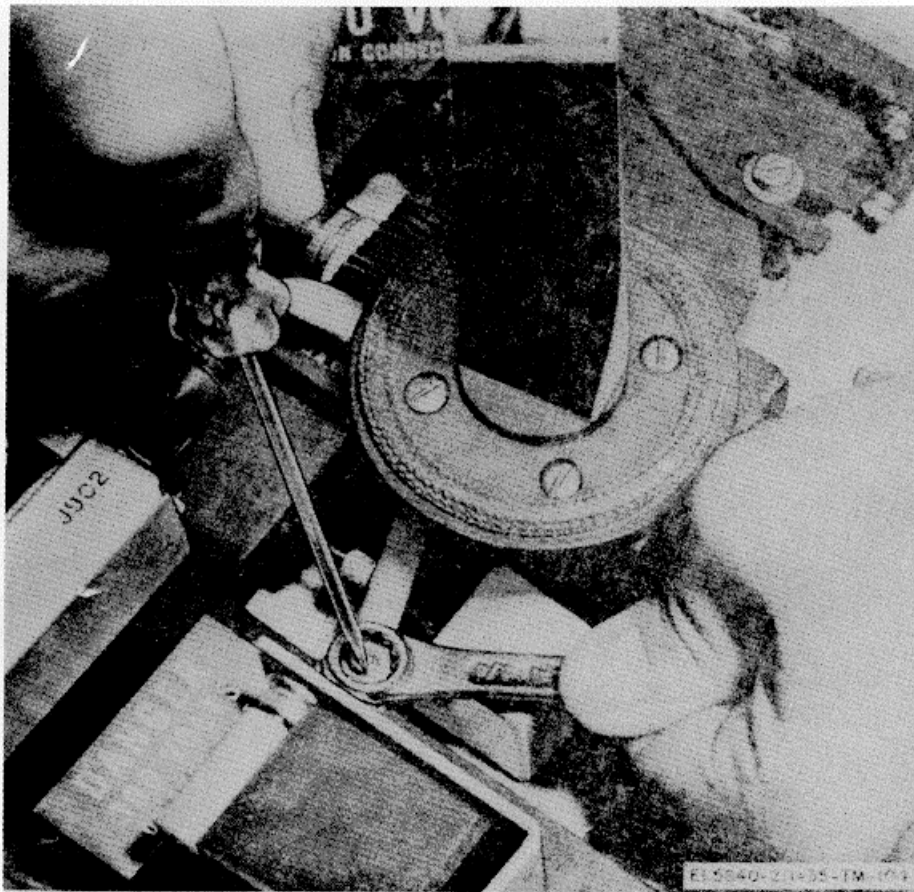

Figure 3-66. Position of 3/8 inch box wrench and screwdriver.

(3) Guide plug P902 and associated cable up and between the antenna feed assembly and a/c knurled attenuator knob (fig. 3-62).

(4) Before performing the procedures given in this subparagraph, read the caution below. Hold hybrid waveguide assembly No. 1 with the left hand, and hybrid waveguide assembly No. 2, just forward of klystron V902, with the right hand. Tilt the waveguide assembly toward the MAG TUNER opening (fig. 3-62) on the center section, slowly set the waveguide assembly into the center section so that the three adjustment screws (fig. 3-67) fit into the holes provided on the microwave assembly and, at the same time, observe that the microwave assembly locating hole mates with the center section center locating pin (fig. 3-67), magnetron V901 knurled tuning knob is exposed through the MAG TUNER opening, and magnetron V901 knurled tuning knob cutout (fig. 3-69) is set directly over the magnetron knurled tuning knob (pin 3-67).

CAUTION

Do not force the microwave assembly. Adjustment screws and center locating pin may be damaged.

(5) Replace the BNC connector on magnetron V901 (fig. 3-62).

(6) Replace the ground lead lug (fig. 3-61) with attaching hardware in the following sequence: flat lockwasher between the waveguide assembly and ground lead lug, and split lockwasher between ground lead lug and securing 8-32 bolt.

(7) Replace one 10-32 bolt with the flat washer and lockwasher in the mating hole near jack J8 (fig. 3-62).

(8) Replace the magnetron connector clamp and secure it and the microwave assembly with two lockwashers, two flat washers, and two 10-32 bolts.

(9) Align the holes of plug P902 with the pins of J902 and mate; position the spring clamp and secure it by turning the knurled outer casing of P902 (fig. 3-62).

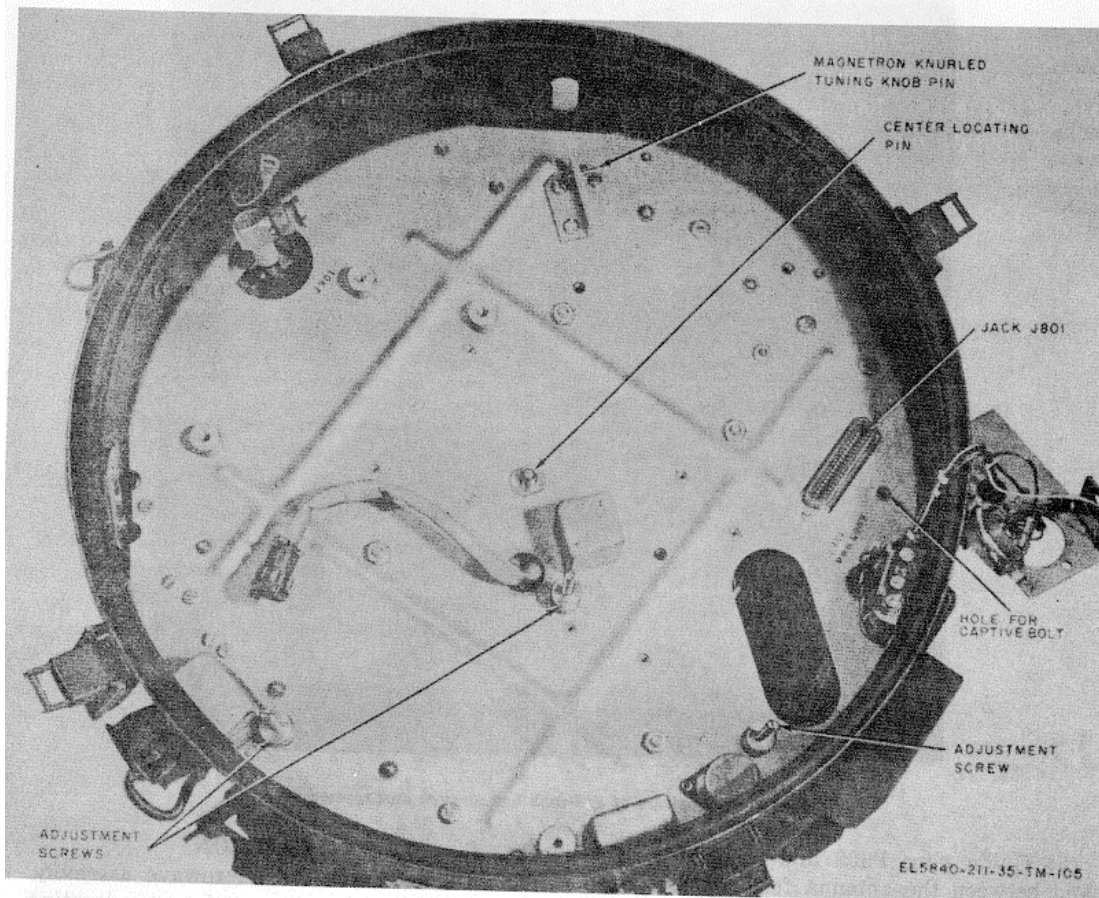

Figure 3-67. Center section with microwave assembly removed.

(10) Before performing the procedures given here, read the caution below. Set a flatwasher over the adjustment screw under klystron V902, a lockwasher on top of the flat washer, and a 10-32 hexagonal locknut on top of the adjustment screw.

CAUTION

The 10-32 hexagonal locknut must not be turned at this time. Turning the 10-32 hexagonal locknut will also turn the adjustment screw and cause the seating of the microwave assembly to change. This in turn, will set the dipole off the focal point and cause erroneous azimuth readings, a broad radiated beam, and a decrease in the maximum distance at which a target may be picked up.

(11) Before performing the procedures given here, read the caution below. Set a screwdriver

into the slot of the adjustment screw. Hold the screwdriver so that the adjustment screw does not turn, and thread the adjustment screw finger-tight.

CAUTION

Do not use an oversized screwdriver in the adjustment screw slot because the slot will spread, and replacement of the hexagonal locknut will strip the adjustment screw threads.

(12) Remove the screwdriver, set a 3/8-inch box wrench over the 10-32 hexagonal locknut, replace the screwdriver in the adjustment screw slot, hold the screwdriver so that the adjustment ; screw does not turn, and secure the hexagonal locknut with the 3/8-inch box wrench (Refer to figure 3-66 for correct position of screwdriver and box wrench.)

to mate plug P801, on the power converter, with jack J801; secure with four captive bolts.

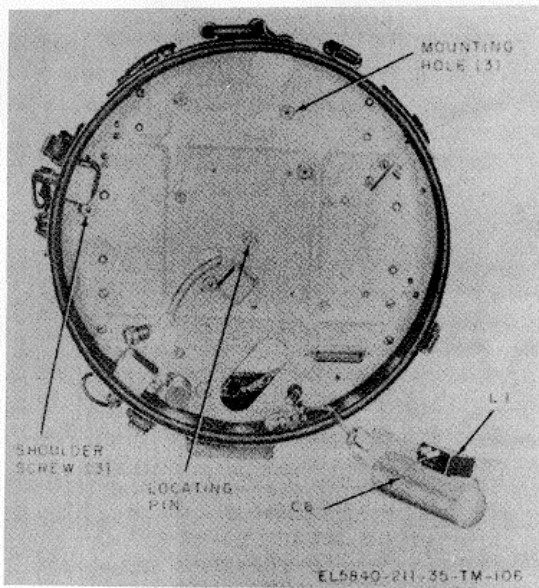

Figure 3-68. Receiver-transmitter, center section, front side, microwave assembly removed.

(13) Set the bracket assembly in position on the microwave assembly (fig. 3-65).

(14) Secure the bracket assembly and microwave assembly with two 10-32 hexagonal locknuts. Refer to the procedure outlined in (10) through (12) above.

(15) Replace capacitor C6 socket (fig. 3-65) with two 6-32 bolts, two flat washers, and two lockwashers.

(16) Before performing the procedure given here, read the caution below. Place capacitor C6 bracket on capacitor C6 and insert the capacitor into its socket.

CAUTION

Make sure that klystron V902 (fig. 3-62) tuning bow is not accidentally moved; if the tuning bow should turn, a complete alignment may be required.

(17) Secure capacitor C6 bracket with 832 bolt, flat washer, and lockwasher (fig. 3-62). Make sure capacitor C6 is held firmly seated in its socket to insure good contact between capacitor C6 pins and its socket.

(18) Replace the power converter by grasping the power converter with both hands and setting it into position so that the captive bolt near jack J801 (fig. 3-67) sets on its mating hole. Slowly press down the power converter

(19) Before performing the procedure given here, read the caution below. Position the center section on its side so that the afc unit can be re-placed.

CAUTION

Do not position the center section to allow the antenna feed assembly to support the center section.

(20) Before performing the procedure given here, read the caution below. Mate IF amplifier unit plug P504 with crystal jack J905, IF amplifier unit plug P505 with crystal jack J906, and afc unit plug P703 with crystal jack J907. Use only fingers to mate and lock BNC connectors on crystal jacks J905, J906, and J907 (fig. 3-64).

CAUTION

Do not use pliers. Make sure no side pressure is applied because the crystal jacks will snap off.

(21) Replace the afc unit by aligning the captive bolts with their mating holes and carefully mate plug P701, at the back of the afc unit, with jack J701 (fig. 3-64).

c. Removal of Magnetron V901. Before the removal of magnetron V901 (fig. 3-62) is possible, the microwave assembly must first be removed as outlined in a above. Remove magnetron V901 as follows:

(1) Remove three 8-32 bolts with three lockwashers that secure magnetron V901 to hybrid waveguide assembly No. 1 (fig. 3-70).

(2) Remove the knurled tuning knob from magnetron V901 by loosening the setscrew on the knurled tuning knob and sliding the knurled tuning knob from magnetron V901 tuning shaft (fig. 3-69).

d. Replacement of Magnetron V901.

(1) Before performing the procedure given here, read the note below. Secure magnetron V901 to hybrid waveguide assembly No. 1 with three 8-32 bolts and three lockwashers (fig. 3-70).

NOTE

Do not install a bolt in the 832 hole reserved for the ground lead lug connection (fig. 3-62).

(2) Before performing the procedures given here, read the note below. Slide magnetron V901 knurled tuning knob over magnetron V901 tuning shaft and secure the knob with the setscrew (fig. 3-69)

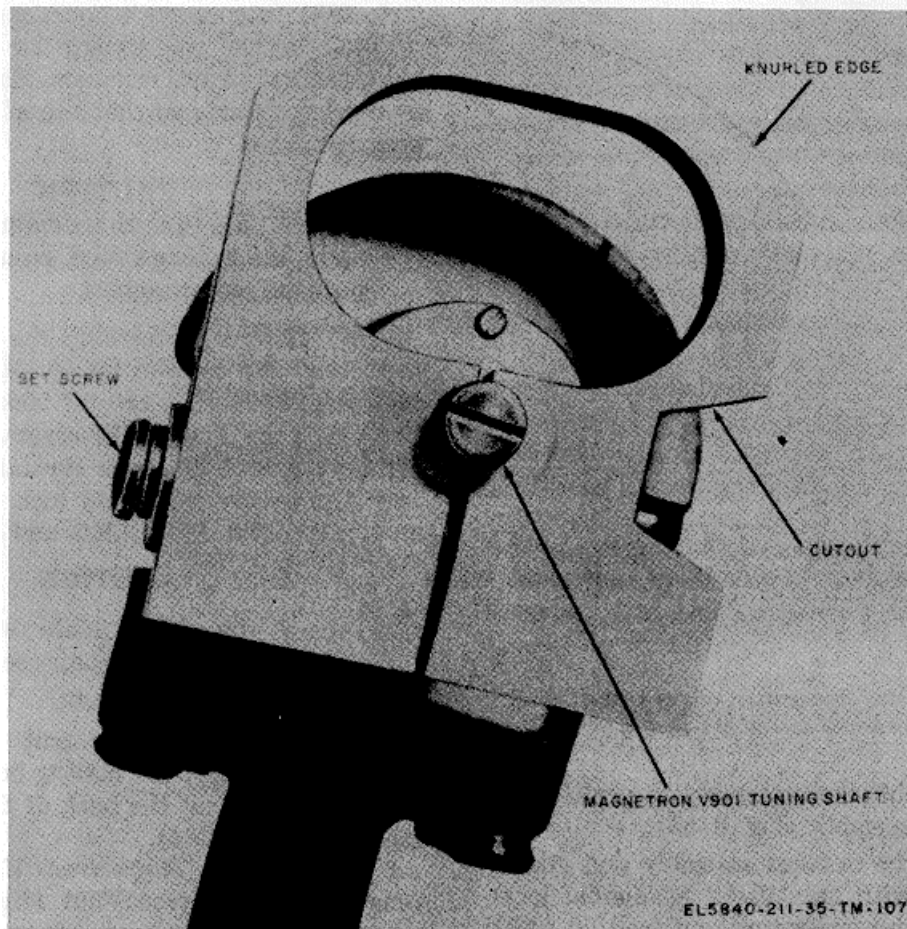

Figure 3-69. Magnetron V901 , knurled tuning knob assembled.

NOTE

The correct position for the magnetron knurled tuning knob is illustrated in figure 3-70. Do not turn the magnetron tuning shaft, because it has been factory preset.

e. Removal of Pulse Unit Z201. Remove pulse unit Z201 (fig. 3-14) from the transmitter unit as follows:

(1) Proceed as instructed in paragraph 3-61 a (1) through (7).

(2) Tag and unsolder the leads from the side of pulse unit Z201.

(3) Remove the four binding head screws and lockwashers that secure pulse unit Z201 to the transmitter unit plate and remove the pulse unit.

f. Replacement of Pulse Unit Z201. Replace pulse unit Z201 in the transmitter unit as follows: (1) Align pulse unit Z201 on the transmitter unit plate (fig. 3-14) and secure the pulse

unit in place with four No. 6-32 x 1/2 binding head screws and four No. 6 lockwashers.

(2) Solder the tagged leads to the terminals of pulse unit Z201.

(3) Perform procedures given in paragraph 3-61 b (1) through (6).

3-68. RF System

CAUTION

When replacing the radome, make sure that the guide flange (fig. 3-72) does not come in contact with the insulation sleeve (fig. 3-73) which protects the resistor lead attached to the socket of capacitor C6. If the guide flange is allowed to rub or gouge the insulation sleeve, the bare lead will be exposed and short circuited to the radome flange, causing the equipment to become inoperative.

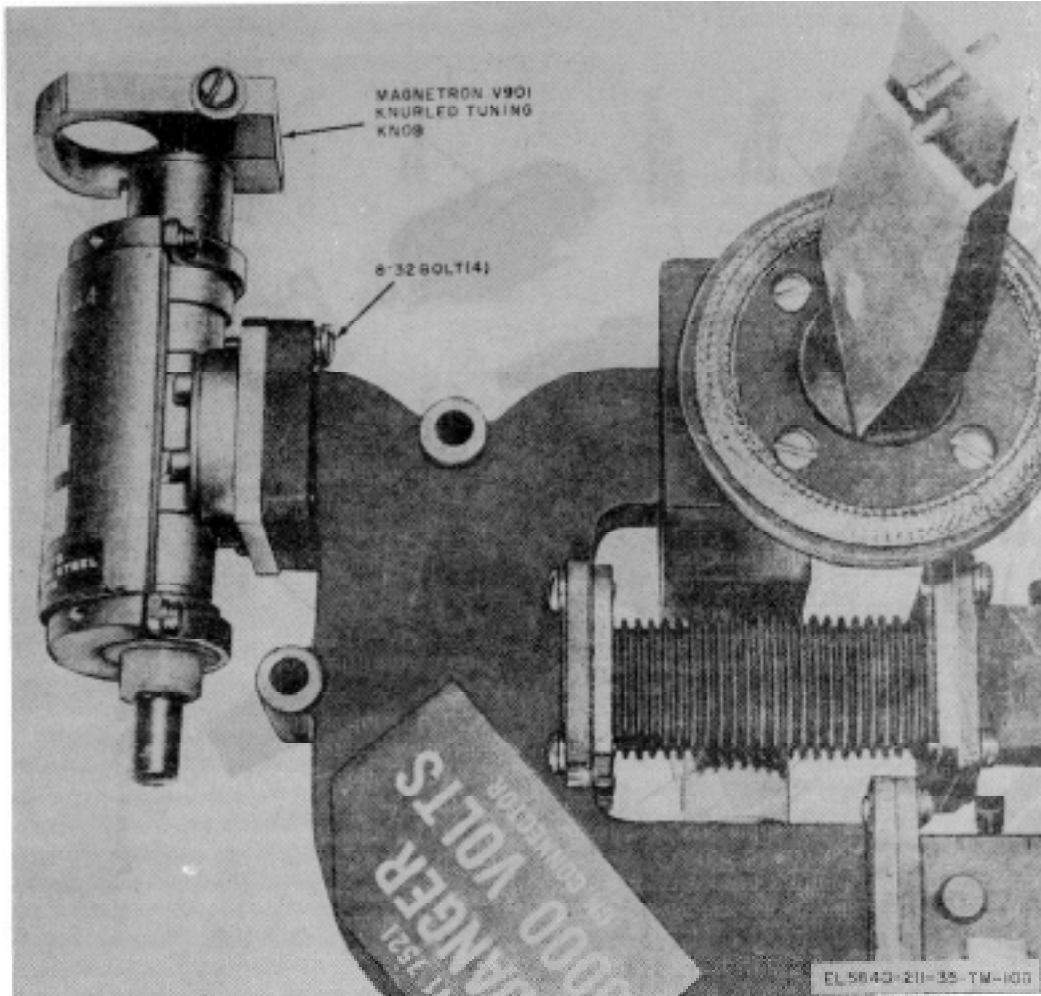

Figure 3-70. Correct position for magnetron V901 knurled tuning knob.

a. General.

(1) Physically, the RF system consists of hybrid waveguide assembly No. 1 (fig. 3-71), hybrid waveguide assembly No. 2, dual-channel limiter, the flexible waveguide assembly, the antenna feed assembly, the parabolic reflector, the klystron shield, and associated gaskets.

(2) The removal and replacement of parts in the RF system, with the exception of the antenna feed assembly and the parabolic reflector, necessitates the removal of the entire microwave assembly from the receiver-transmitter housing.

Refer to paragraph 3-67 for removal and replacement procedures of the microwave unit.

(3) To prevent dirt or other foreign matter from entering sections of the waveguide, cap or tape shut the waveguide openings during the removal and replacement of parts on the RF system.

(4) When replacing the antenna feed assembly, make sure that the rectangular waveguide opening in the antenna feed assembly is aligned with the rectangular waveguide opening in the microwave assembly (fig. 3-75).

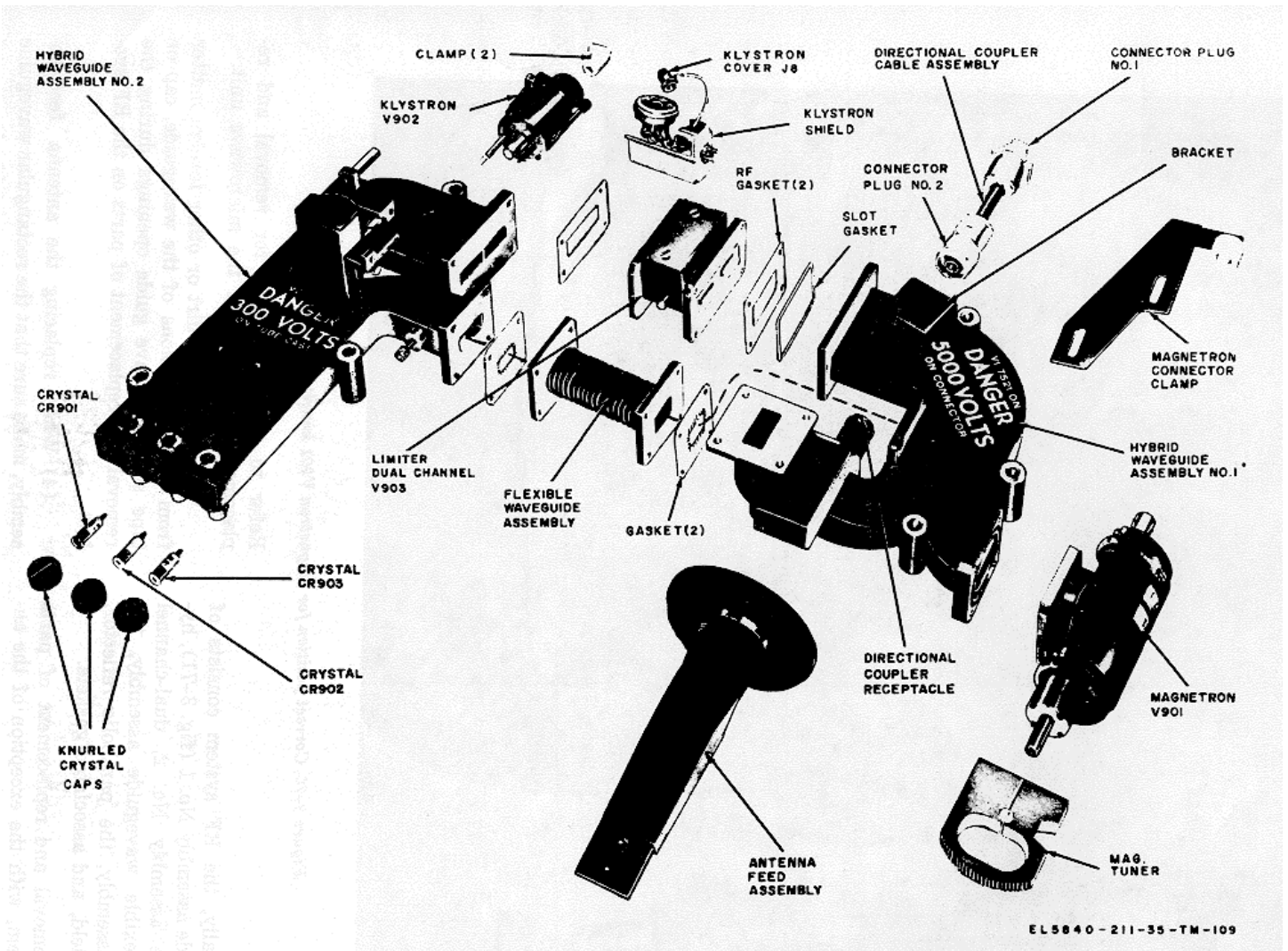

Figure 3-71. RF system, exploded view.

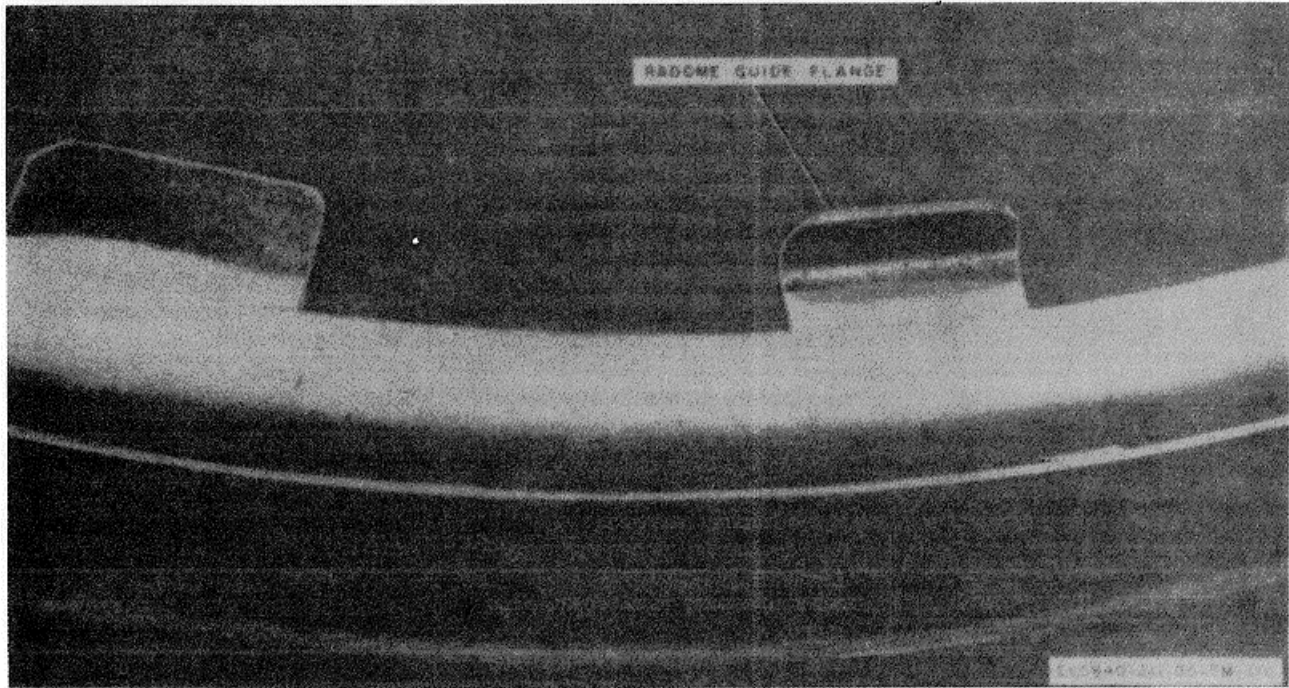

Figure 3-72. Radome guide flange exposed.

WARNING

Extremely dangerous voltages exist on klystron V902 and magnetron V901 (mounted on the RF system). When removing or replacing parts in the RF system, check to see that the battery input cable is disconnected from the control panel.

b. Removal of Dual-Channel Limiter. Before the removal of dual-channel limiter V903 (fig. 3-71) is possible, the microwave unit must first be removed as outlined in paragraph 3-67. Remove dual-channel limiter V903 as follows:

(1) Remove klystron V902 plastic clamp by unscrewing one 6-32 bolt with flat washer and lockwasher (fig. 3-77) to expose a securing bolt (fig. 3-78) for dual-channel limiter V903.

(2) Insert a screwdriver under klystron tube V902 and remove 832 bolt with lockwasher from dual-channel limiter V903 (fig. 3-78).

(3) Remove the remaining three 8-32 bolts with three lockwashers from the same side of dual-channel limiter V903 as in (2) above (side of dual-channel limiter that mates with hybrid waveguide assembly No. 2).

(4) Flex the waveguide slightly and carefully remove the rf gasket (fig. 3-71).

(5) Flex the waveguide so that a screwdriver can be positioned above klystron V902 to remove the top two 832 bolts with two lockwashers that secure dual-

channel limiter V903 to waveguide assembly No. 1 (fig. 3-79).

(6) Remove the bottom two 842 bolts with two lockwashers that secure dual-channel limiter V903 to waveguide assembly No. 1.

(7) Remove dual-channel limiter V903 with RF gasket and slot gasket (fig. 3-71).

c. Replacement of Dual-Channel Limiter V903 and Microwave Assembly.

(1) Before performing the procedures given here, read the note below. Flex the waveguide (fig. 3-62), place the slot gasket, RF gasket, and dual-channel limiter V903 (fig. 3-71) flush against hybrid waveguide assembly No. 1 (magnetron V901 is located on waveguide assembly No. 1).

NOTE

The dual-channel limiter must be positioned so that the input port is closer to hybrid waveguide assembly No. 1 (klystron V902 is located on hybrid waveguide assembly No. 2).

(2) Secure the slot gasket, RF gasket, and dual-channel limiter V903 with four 832 bolts and four lockwashers.

(3) Place the RF gasket between dual-channel limiter V903 and hybrid waveguide assembly No. 2 (fig. 3-71).

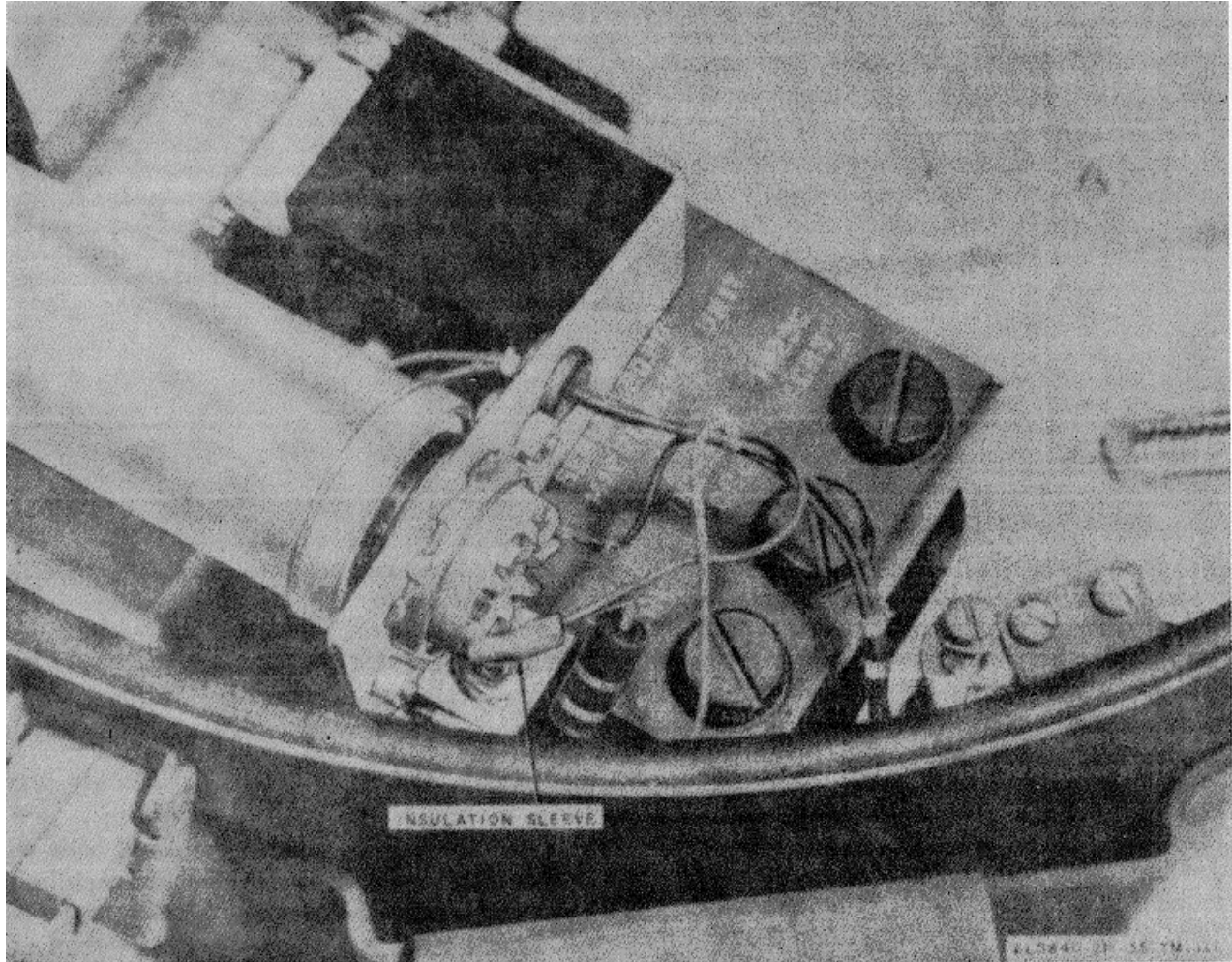

Figure 3-73. Bracket assembly showing insulation sleeve.

(4) Align dual-channel limiter V903 with hybrid waveguide assembly No. 2.

(5) Secure dual-channel limiter V903 to hybrid waveguide assembly No. 2 with four 8-32 bolts and four lockwashers.

(6) Replace klystron V902 plastic clamp and secure with the 6-32 bolt, flat washer, and lockwasher (fig. 3-77).

d. Removal of Flexible Waveguide Assembly.

(1) Remove the four binding head screws and four lockwashers that fasten the flexible waveguide assembly (fig. 3-71) to each of the two mating flanges on hybrid waveguide assemblies Nos. 1 and 2, and remove the flexible waveguide assembly.

(2) Remove the two gaskets which are located on the flanges of the flexible waveguide assembly.

e. Replacement of Flexible Waveguide Assembly.

(1) Install the gaskets on the flanges of the flexible waveguide assembly.

(2) Install a new flexible waveguide assembly between the flanges of hybrid waveguide assemblies No. 1 and 2.

(3) Fasten the flexible waveguide assembly and the gaskets to the flanges of the hybrid waveguide assemblies No. 1 and 2, using four No. 8-32 x 3/8 binding head screws and four No. 8 lockwashers in each flange.

f. Removal of Directional Coupler Cable Assembly.

(1) Remove the four screws and four lockwashers that fasten the flange on connector plug No. 1 of the directional coupler cable assembly to the bracket welded to hybrid waveguide assembly No. 1. Remove the chain connected to connector plug No. 1.

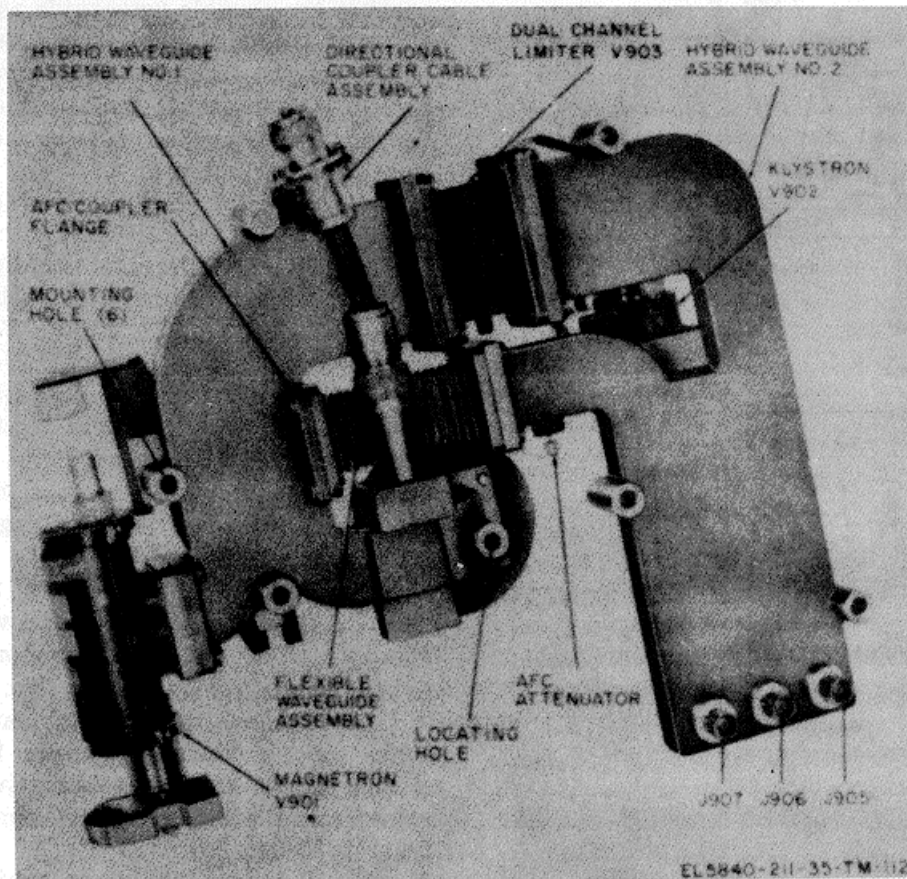

Figure 3-74. RF system with klystron, magnetron, and crystals attached.

(2) Unscrew the knurled nut on connector plug No. 2 of the directional coupler cable assembly and pull the cable assembly free from the directional coupler receptacle.

g. Replacement of Directional Coupler Cable Assembly.

(1) Insert connector plug No. 2 of a new directional coupler cable assembly into the directional coupler receptacle. Tighten the knurled nut on connector plug No. 2.

(2) Fasten the flange on connector plug No. 1 to the bracket on hybrid waveguide assembly No. 2, using four No. 440 x 1/4 binding head screws and four No. 4 lockwashers. Insert one of the screws through the eyelet of the chain on connector plug No. 1.

h. Removal of Hybrid Waveguide Assembly No. 1.

(1) Remove the four binding head screws and four lockwashers that fasten the mating flange of dual-channel limiter V903 (fig. 3-71) to hybrid waveguide assembly No. 1.

(2) Remove the RF gasket and the slot gasket from the mating flange of hybrid waveguide assembly No. 1.

(3) Remove the four binding head screws and four lockwashers that fasten the mating flange of the flexible waveguide assembly to hybrid waveguide assembly No. 1 and remove hybrid waveguide assembly No. 1.

(4) Remove the gasket from the mating flange of the flexible waveguide assembly.

(5) Remove the four binding head screws and four lockwashers that fasten the mating flange of the antenna feed assembly to hybrid waveguide assembly No. 1, and remove the antenna feed assembly.

(6) Remove magnetron V901 as directed in paragraph 3-67.

i. Replacement of Hybrid Waveguide Assembly No. 1.

(1) Replace magnetron V901 as directed in paragraph 3-67.

(2) Install the antenna feed assembly on hybrid waveguide assembly No. 1 and fasten the

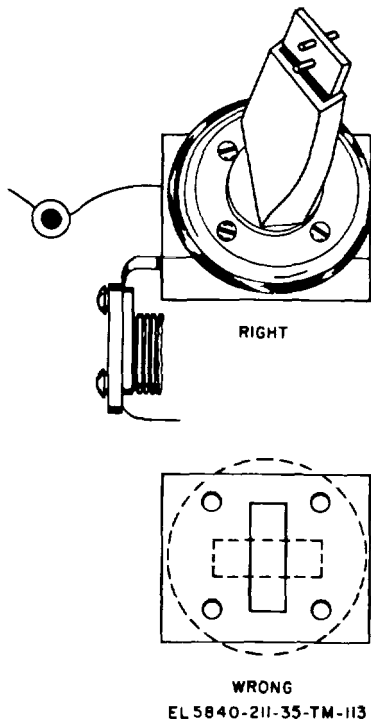

Figure 3-75. Right and wrong way to mate feed assembly.

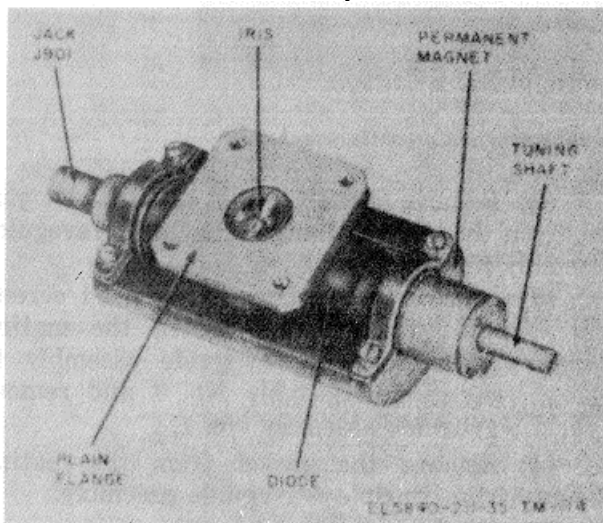

Figure 3-76. Magnetron V901.

assembly in place with four No. 4-40 x 1/4 binding head screws and four No. 4 lockwashers.

(3) Install a slot gasket and an RF gasket on the mating flange of hybrid waveguide assembly No. 1 connected to dual-channel limiter V903.

(4) Install dual-channel limiter V903 on mating flange connected to hybrid waveguide assembly No. 1 and fasten the dual-channel limiter V903 in place with

four -32 x 3/8 binding head screws and four No. 8 lockwashers.

(5) Install a gasket on the mating flange of hybrid waveguide -assembly No. 1 which connects to the flexible waveguide assembly.

(6) Install the flexible waveguide assembly on the mating flange of hybrid waveguide assembly No. 1, and fasten the assembly in place with four No. 8-32 x 3/8 binding head screws and four No. 8 lockwashers.

j. Removal of Hybrid Waveguide Assembly No. 2.

(1) Remove the four binding head screws and four lockwashers that fasten the mating flange of dual-channel limiter V903 (fig. 3-71) to hybrid waveguide assembly No. 2.

(2) Remove the four binding head screws and four lockwashers that fasten the mating flange of the flexible waveguide assembly No. 2. Remove hybrid waveguide assembly No. 2, and the gasket from the mating flange of the flexible waveguide assembly.

(3) Remove the two hex nuts, two lockwashers, and two plain washers which secure the klystron shield to the two shoulder screws in hybrid waveguide assembly No. 2.

(4) Remove the reflector cap from klystron V902. Loosen the two screws that secure the clamps on the klystron socket. Swing the clamps away from the tube base and remove the klystron from its socket.

(5) Remove the screw which secures the klystron socket to hybrid waveguide assembly No. 2 -and remove the klystron shield with the klystron socket and reflector cap attached.

(6) Remove the two shoulder screws from hybrid waveguide assembly No. 2.

(7) Unscrew the knurled caps covering the three crystals CR901, CR902, and CR903. Remove the crystals from their receptacles.

k. Replacement of Hybrid Waveguide Assembly No. 2.

(1) Install crystals CR901, CR902, and CR903 in their receptacles on the new hybrid waveguide assembly No. 2. Screw on the knurled caps.

(2) Replace the two shoulder screws in hybrid waveguide assembly No. 2 and install the klystron shield in position. Secure the klystron shield by replacing the two plain washers, two lockwashers, and two hex nuts on the shoulder screws, and by replacing the screws securing the klystron socket.

(3) Install klystron V902 in its socket. Swing the clamps toward the tube socket and tighten the two screws that secure the klystron to the klystron socket. Replace the reflector cap.

(4) Position the RF gasket on the mating flange of hybrid waveguide assembly No. 2. Install dual channel

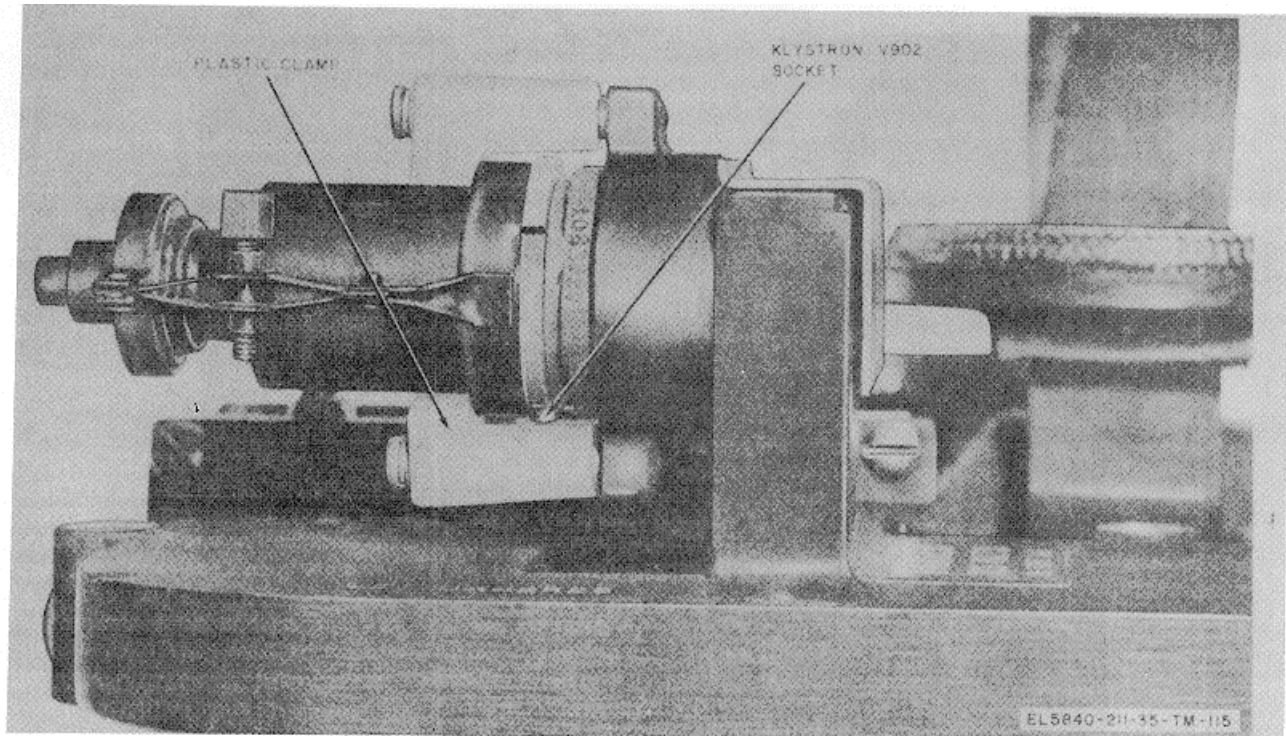

Figure 3-77. Location of klystron V902 plastic clamp and socket.

channel limiter V903 to the mating flange of hybrid waveguide assembly No. 2 and fasten the dual-channel limiter in place with four No. 8-32 x 3/8 binding head screws and four No. 8 lockwashers.

(5) Install the gasket on the mating flange of the flexible waveguide assembly which connects to hybrid waveguide assembly No. 2.

(6) Install the mating flange of the flexible waveguide assembly to hybrid waveguide assembly No. 2, and fasten the assembly in place with four No. 8-32 x 3/8 binding head screws and four No. 8 lockwashers.

l. Removal of Antenna Feed Assembly. Remove the four binding head screws and four lockwashers that fasten the antenna feed assembly (fig. 3-71) to the mating flange of hybrid waveguide assembly No. 1, and remove the antenna feed assembly.

m. Replacement of Antenna Feed Assembly. Install the antenna feed assembly on the mating flange of hybrid waveguide assembly No. 1, and fasten the assembly in place with four No. 8-40 x 3/8 binding head screws and four No. 8 lockwashers.

3-69. Receiving System

The receiving system consists of the components in the IF amplifier unit, the klystron, and the signal mixer crystals.

WARNING

A potential of 270 volts exists on the outer case of klystron V902.

a. Removal of klystron V902.

(1) Place the POWER switch in the OFF position.

(2) Remove the microwave assembly from the receiver-transmitter as described in paragraph 3-67.

(3) Remove the reflector cap from the klystron (fig. 3-71). Loosen the two -screws that secure the clamps on the klystron socket. Swing the clamps away from the tube base and remove the klystron from its socket.

b. Replacement of Klystron V902.

(1) Place the POWER switch in the OFF position.

(2) Replace the klystron in its socket. Swing the clamps toward the tube socket and tighten the two screws that secure the klystron to the klystron socket. Replace the reflector cap.

(3) Replace the microwave assembly in the receiver-transmitter housing as described in paragraph 3-67.

c. Removal of CR901 and CR902.

(1) Place the POWER switch in the OFF position.

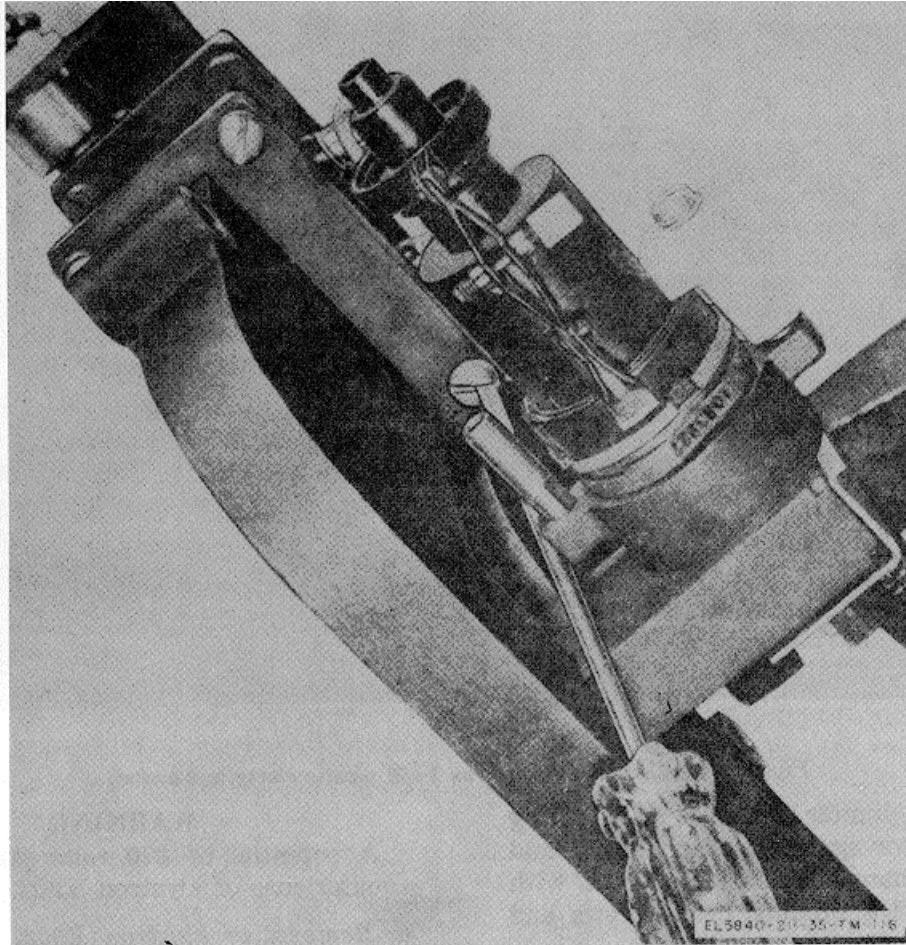

Figure 3-78. Placement of screwdriver.

(2) Remove the radome from the control panel (para. 3-59).

(3) With a screwdriver, unscrew the knurled caps covering crystals CR901 and CR902 and remove them from their receptacles with long-nosed pliers.

d. Replacement of CR901 and CR902.

(1) Replace CR901 and CR902 in their receptacles.

(2) Screw on the knurled caps.

(3) Install the radome and engage the four trunk-type latches that fasten the radome on the front of the receiver-transmitter.

e. Removal and Replacement of the IF Amplifier Unit. For removal and replacement procedures of the IF amplifier u-nit, refer to paragraph 3-63.

3-70. Indicator, Azimuth

a. Removal.

(1) Remove the two binding head screws that secure the azimuth indicator clip to the support casting.

(2) Remove the azimuth indicator clip.

(3) Remove the azimuth indicator from the azimuth indicator clip.

b. Replacement.

(1) Insert the azimuth indicator into the azimuth indicator clip.

(2) Position the azimuth indicator clip on the tripod head.

(3) Install two binding head screws.

3-71. Tripod Leg Assembly

Remove and replace the tripod leg assembly following the procedures outlined in TM 11-5840-211-12

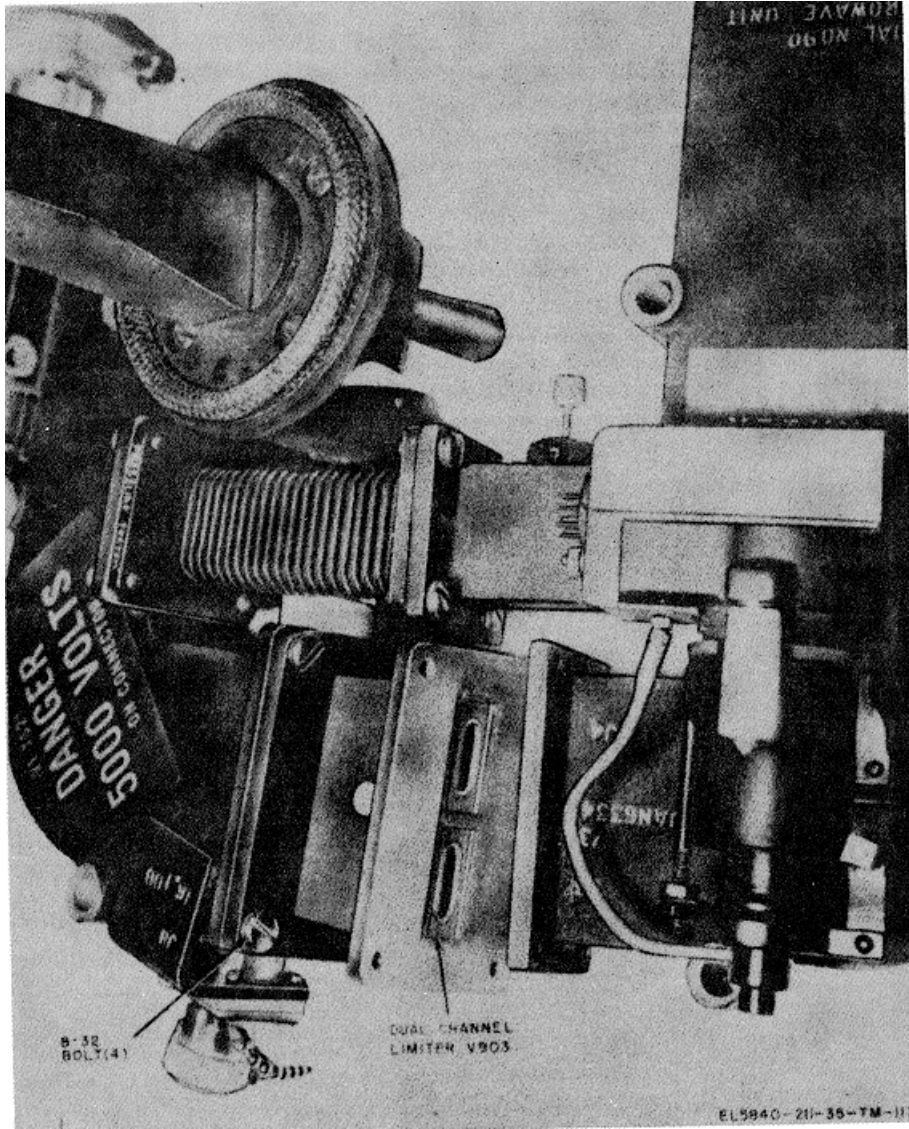

Figure 3-79. Waveguide in flexed position.

CHAPTER 4

DIRECT SUPPORT TESTING PROCEDURES

4-1. General

This chapter contains test procedures and lists the test equipment required to check the serviceability of repaired Radar Set AN/PPS-4A. Follow the procedure steps in the order given. Set the controls as accurately as possible while performing the test procedures.

4-2. Testing the Transmitting System

Paragraphs 4-3 through 4-6 describe the testing procedures required to check the serviceability of a repaired transmitting system when the components of the radar set are interconnected.

NOTE

Procedures to test the magnetron frequency are given in paragraph 3-41.

4-3. Magnetron Filament Voltage Test

a. Test Equipment and Materials.

- (1) Oscilloscope AN/USM-281.
- (2) Repair patchcord.
- (3) Control panel support fixture.

b. Preparing System Components for Testing. To make the transmitting system accessible for testing, perform the following procedures:

- (1) Release the four trunk-type latches that fasten the control panel on the receiver-transmitter, and remove the control panel.

CAUTION

Care should be taken in handling the control panel to prevent damage to meter M101, the strobe unit, and exposed soldered connections.

(2) Place the control panel in the support fixture.

(3) Connect the repair patchcord between plug P101 on the control panel and receptacle J101 on the rear of the center section.

(4) Remove the cover of the transmitter unit by unscrewing four binding head screws, and lifting off the cover (fig. 3-12).

c. Test Confections and Conditions. Insert the oscilloscope probes at pins 1 and 3 of pulse unit Z201 (fig. 3-14).

d. Initial Test Equipment Calibration. Set the oscilloscope to measure ac voltage. Set up oscilloscope as described in the applicable instruction manual.

WARNING

Perform this test with the POWER switch in the STANDBY position. Otherwise, 5,000 volts will be present at the magnetron filaments.

e. Test Procedure.

Step No.	Control settings		Test procedure	Performance standard
	Test equipment	Equipment under test		
1	<ul style="list-style-type: none"> a. Set the POWER switch on the AN/PPS-4A to STANDBY. b. Observe the AN/USM-281 scope indication. c. Set the POWER switch on the AN/PPS-4A to OFF. d. Disconnect the AN/USM-281. Remove the repair patchcord from jack J101 and plug P101. Replace the control panel on the receiver-transmitter and fasten the four trunk-type latches to secure the control panel in place (para 3-59). 	<ul style="list-style-type: none"> a. None. b. The AN/USM-281 scope must indicate a square wave, 14+/- 2 volts c. None. d. None.

4-4. Trigger Output Test

This test checks the range trigger winding output to the IF amplifier unit.

- a. *Test Equipment and Materials.*
 - (1) Oscilloscope AN/USM-281.
 - (2) Repair patch cord.
 - (3) Control panel support fixture.

- b. *Test Connections and Conditions.*

(1) Make the transmitting system accessible (para. 43b).

(2) Place the AN/USM-281 probe at jack J206 (fig. 3-14) on the transmitter unit.

c. *Initial Test Equipment Calibration.* Calibrate the AN/USM-281 as indicated in the applicable instruction manual.

- d. *Test Procedure.*

Step No.	Control settings		Test procedure	Performance standard
	Test equipment	Equipment under test		
1	<ul style="list-style-type: none"> a. Set the POWER switch on the AN/ PPS-4A at OFF. b. Allow 90-second warmup period c. Observe the AN/USM 1 d. Set the POWER switch on the AN/d PPS-4A at OFF. e. Disconnect AN/USM-J2S1 probese Remove repair patchcord and replace the control panel on the receiver-transmitter (para. 3-59). 	<ul style="list-style-type: none"> a. None. b. None. c. A negative 60 f±- volt waveform must be observed on the AN/USM-281 scope. d. None. e. None.

4-5. Magnetron current and Trigger Output Pulse Tests

- a. *Test Equipment and Material.*
 - (1) Multimeter TS352B/U.
 - (2) Oscilloscope AN/USM-281.
 - (3) Control panel support fixture.
- b. *Test Connections and Conditions.*
 - (1) Make the transmitting system accessible (para. 43b).

(2) Place AN/USM-281 probe at jack J421 on the range unit (fig. 3-55).

(3) Connect TS-352B/U leads across jacks J204 and J205 on the transmitter unit (fig. 3-14).

c. *Initial Test Equipment Calibration.* Calibrate the AN/USM-281 as indicated in the applicable instruction manual.

- d. *Test Procedure.*

Step No.	Control settings		Test procedure	Performance standard
	Test equipment	Equipment under test		
1	Set the POWER switch on the AN/ PPS-4A at TRANSMIT.	None.
2	Observe the TNS-352B/U voltmeter indication	The TS d1B/U voltmeter must indicate between 0.4 and 1.7 volt dc.
3	Observe the AN/USM-281 scope indication	Waveform (A, fig. 3-6) must be present on scope.
4	Set the POWER switch on the AN/ PPS-4A at OFF.	None.
6	Disconnect the AN/USM--281 and TS-352B/U. Remove repair patch-cord and replace the control panel on the receiver transmitter (para. 3-9).	None.

4-6. Pulse Width, Repetition Rate, and Power Output Tests

- a. *Test Equipment and Material.*
 - (1) Oscilloscope AN/USM-281.
 - (2) Test Set, Radar TS-147D/UP.

- (3) Repair patch cord.
- (4) Plugs for tip jacks.
- (5) Terminated test cable.
- (6) Control panel support fixture.

b. *Test Connections and Conditions.*

(1) Make the transmitting system accessible (para. 4-3b).

(2) Unscrew the cover plate from the directional coupler access hole on the receiver-transmitter housing (fig. 3-63).

(3) Unscrew the cap of the directional coupler cable assembly.

(4) Connect the radar test set RF cable from the radar test set to jack J908 in the access hole.

(5) Place the controls on the radar test set in the transmitter position.

(6) Connect a 50-ohm coaxial cable, terminated in its characteristic impedance, between the vertical input of the oscilloscope and the crystal output jack of the radar test set.

c. *Initial Test Equipment Calibration.* Calibrate the oscilloscope as indicated in the applicable instruction manual.

d. *Test Procedure.*

Step No.	Control settings		Test procedure	Performance standard
	Test equipment	Equipment under test		
1	Set the POWER switch on the AN/PPS-4-A at TRANSMIT.	None.
2	Observe the AN/USM-01 scope indication.	Pulse width as indicator on scope must be 0.2 ±0.02 usec the 50% points Period between pulses as indicated on scope must be from 313.0 to 370.0
3	Observe the AN/USM-281 scope indication.	
4	Observe the TS 147D/P power meter indication.	
5	Place the POWER switch on Radar Set AN/PPS4A to OFF. Remove test equipment cables and the repair patchcord	Power output as indicated on power meter must be between 24 and 27 dbm. None
6	Install the control panel on the receiver transmitter (para. 3-59).	None.

4-7. Testing the Receiving System

Paragraph 44-8 describes the testing procedures required to check the serviceability of a repaired receiving system when the components of the radar set are interconnected.

4-8. Receiver Sensitivity Test

a. *Test Equipment and Materials.*

- (1) Oscilloscope AN/USM-281.
- (2) Test Set, Radar TS-147D/UP.
- (3) Repair patch cord.
- (4) Control panel support fixture.

b. *Test Connections and Conditions.*

(1) Make the transmitting system accessible (para. 4-3b).

(2) Unscrew the cover plate from the directional coupler access hole on the receiver-transmitter housing (fig. 3-63).

(3) Unscrew the cap of the directional coupler cable assembly.

(4) Connect the radar test set RF cable from the jack on the test set to jack J908 in the access hole.

(5) Connect jack J403 on the range unit (fig. 3-55) to the vertical input of the AN/USM-281.

(6) Connect the output of jack J401 on the range unit to the trigger input jacks of the AN/USM-281 and TS-147D/UP. Synchronize the AN/USM-281 externally.

c. *Initial Test Equipment Calibration.* Calibrate the oscilloscope as indicated in the applicable instruction manual.

d. *Test Procedure.*

Step No.	Control settings		Test procedure	Performance standard
	Test equipment	Equipment under test		
1	Place POWER switch on the AN/PPS-4A at TRANSMIT	None.

Step No.	Control settings		Test procedure	Performance standard
	Test equipment	Equipment under test		
2	Set the TS-4470/UP for receiver operation and adjust frequency Control. Observe AN/USM-281 scope	Targets must appear on the AN/USM-281 scope.
3	Adjust the DBM attenuator control on the TS 147D/UP to obtain an output with no attenuation.	One milliwatt must be indicated on the meter of T-147D/UP.
4	Adjust the DBM attenuator control on the TS-147D/UP until the ungated target is twice the amplitude of the ungated noise as indicated on the AN/USM-281 scope.	The total attenuation is equal to the receiver sensitivity and must be 85 or more dbm. (The total Attenuation is equal to the sum of the indication on the calibrated DBM attenuator dial on the TS-147D/UP, the attenuation of the TS-147D/UP calibrated RF cable, and the attenuation of the directional coupler in AN/PPS-4A. The calibrated attenuation of the RF cable is stamped on the cable and the attenuation of the directional coupler is stamped on the bracket adjacent to jack J908 on the microwave assembly.)
5	Set the POWER switch on the AN/PPS-4A at OFF and deenergize the AN/USM-281 and TS-147D/UP.	None.
6	Remove all test cables and the repair patch cord. Perform procedures given in paragraph 3-59 to reassemble the receiver-transmitter.	None.
7	Replace the cap on the directions coupler cable assembly; replace cover plate on the direction coupler.	None.

4-9. Testing the Automatic Frequency Control System

Paragraph 4-10 describes testing procedures required to check the serviceability of a repaired afc system.

4-10. Afc System Performance Test

a. Test Equipment and Materials. Spectruz Analyzer TS-148/UP is required to test the afc system performance.

b. Test Connections and Conditions.

(1) Remove cover from the directional coupler J908 access hole in the receiver-transmitter housing.

(2) Place the pickup horn of the TS-148, UP over the directional coupler J908 access hole

c. Initial Test Equipment Calibration. Set up the TS-148/UP as indicated in TM 11-1249

d. Test Procedure.

Step No.	Control settings		Test procedure	Performance standard
	Test equipment	Equipment under test		
1	a. Set the POWER switch on the AN/PPS-4A at TRANSMIT, depress the BATTERY TEST switch, and adjust the VOLTAGE ADJ switch S102 until the needle of the RANGE EXTENSION METERS meter M101 indicates in the center of the red zone.	a. None.

Step No.	Control settings		Test procedure	Performance standard
	Test equipment	Equipment under test		
2	b Observe the spectrum display on the TS-148/UP. a Set the POWER switch on the AN/PPSA at STANDBY, wait five seconds, and return POWER switch to the TRANSMIT position. b Set the VOLTAGE ADJ switch one setting above its normal position and repeat above. c Set the VOLTAGE ADJ switch one position below its normal position and repeat a above.	b The klystron frequency should be locked on at 30+/- 1 MHz above the magnetron frequency note. Use the higher frequency display of the two obtainable responses. a Correct lock-on must occur within 5 seconds after POWER switch is returned to TRANSMIT. b Correct lock-on must occur as in a above. c Correct lock-on must occur as in a above.
8	a Remove the cover from the MAG TUNER access hole in the receiver-transmitter housing and rotate the MAG TUNER (fig. 3-50) to its extreme clockwise position. Repeat a, b, and c in step a above. b Rotate the MAG TUNER to its extreme counterclockwise position Repeat a, b and c in step 2 above. c Replace the cover over the MAG TUNER access hole. d Place the POWER switch on the AN/PPS-4A at OFF. Remove the TS-148/UP pickup horn and replace the directional coupler J908 cap and access hole cover.	a Correct lock-on must occur in each step with the klystron frequency 30 +/- 1 MHz above the magnetron frequency. b Correct lock-on must occur as in a above. c None. d None.

4-11. Testing the Ranging System

Paragraph 4-12 through 4-15 describe testing procedures required to check the serviceability of a repaired ranging system when the components are interconnected.

4-12. Short Strobe Test

- a. *Test Equipment and Material.* A stopwatch is required for the short strobe test.
- b. *Test Connections and Conditions.* None.
- c. *Initial Test Equipment Calibration.* The stopwatch must have an accuracy of 0.1% for a 15-second duration.
- d. *Test Procedure.*

Step No.	Control settings		Test procedure	Performance standard
	Test equipment	Equipment under test		
1	Set the POWER switch on the AN/PPS-4A at TRANSMIT.	None.
2	Set the STROBE switch at SHORT	The range gate must strobe through a range of 500 +/-10 meters as indicated on the RANGE EXTENSION meter M101.
3	With stopwatch, measure the time for each strobe cycle.	
4	Set the POWER switch at OFF	The strobe cycle must be 5 +/- 7 seconds as indicated on RANGE EXTENSION meter M101. None.

4-13. Long Strobe Test

- a. *Test Equipment and Material.* A stopwatch is required to perform the long strobe test.
- b. *Test Connections and Conditions.* None.

- c. *Initial Test Equipment Calibration.* The stopwatch must have an accuracy of 0.01% for a 15-second duration.
- d. *Test Procedure.*

Step No.	Control settings		Test procedure	Performance standard
	Test equipment	Equipment under test		
1	Set the POWER SWITCH ON THE AN/ PPS-4A at TRANSMIT.	None
2	Set the STROBE switch at LONG.	The range gate must strobe through a range of 500 +/- 10 meters as indicated on RANGE EXTENSION METERS meter M101.
3	With the stopwatch, measure the time for each strobe cycle	
4	Set the POWER switch at OFF.	The strobe cycle must be 10 +/- 0.5 seconds. None.

4-14. Range Gate Test

- a. *Test Equipment and Material.*
 - (1) Oscilloscope AN/USM-281.
 - (2) Repair patch cord.
 - (3) Control panel support fixture.
- b. *Test Connections and Conditions.*
 - (1) Place POWER switch on the AN/PPS-4A control panel at OFF.
 - (2) Make the transmitter system accessible (para. 4-3b).

- (3) Remove plug P407 from jack J407 and short jack J407 to ground.
- (4) Connect a cable between the vertical input receptacle on the AN/USM-281 to jack J404 on the range unit (fig. 3-55).
- c. *Initial Test Equipment Calibration.* Calibrate the AN/USM-281 as indicated in the applicable instruction manual.
- d. *Test Procedure.*

Step No.	Control settings		Test procedure	Performance standard
	Test equipment	Equipment under test		
1	Set the POWER switch on the AN/PPS-4A control panel at TRANSMIT.	None
2	Set the STROBE switch on the AN/PPS-4A control panel at OFF.	None
3	Set the RANGE METERS indicator on the AN/PPS-4A control panel at 3,000 meters.	None
4	Observe AN/USM-281 indication.	The width of the range gate observed must be 0.23+/- 0.03 usec at the 50% points. The range gate is about +10 volts in amplitude and must be flat and within +/- 0.5 volt, 0.15 usec minimum.
5	Observe AN/USM-281 indication	
6	Observe AN/USM-281 indication	The range gate repetition rate must be within 2,700 and 8,300 pps.
7	Set POWER switch at OFF	None
8	Remove the AN/USM-281 lead from jack J404.	None
9	Connect plug P407 to jack J407	None
10	Remove the repair patchcord and replace control panel on receiver-transmitter	None

4-15. Detector Test

- (1) Oscilloscope AN/USM-281.
- (2) Repair patch cord.
- (3) Control panel support fixture.
- b. *Test Connections and Conditions.*

- (1) Set the POWER switch on the AN/PPS4A control panel at OFF.
- (2) Make the transmitter system accessible (para. 4-3b).

(3) Set the STROBE switch on the AN/PPS-4A control panel at OFF.

(4) Remove plug P407 from Jack J407 and short jack J407 to ground.

(5) Connect AN/USM-281 lead to jack J405 on the range unit.

c. *Initial Test Equipment Calibration.* Calibrate the oscilloscope as indicated in the applicable instruction manual.

d. *Test Procedure.*

Step No.	Control settings		Test procedure	Performance standard
	Test equipment	Equipment under test		
1	a Set the POWER switch on the AN/PPS-4A control panel at TRANSIT. b Allow Minute warmup period..... c Observe AN/USM1 indication.	a None. b None. c The AN/UMX-281 must indicate a negative going sawtooth not exceeding 0.15 volt in amplitude, excluding spikes. The dc level must be a negative 1 volt or more negative, excluding spikes.
2	a Set the POWER switch on the AN/PPS-4A control panel at OFF. b Remove the short from Jack J407 and connect plug P407 to jack J407. c Set the POWER switch on the AN/PPS-4A control panel to RANGE. d Connect the AN/USM-281 lead to Jack J409 on the range unit. e Observe the waveform on AN/USM-281 scope. f Rotate the RANGE CONTROL handwheel until a rangemark is gated, as indicated on the AN/USM-281 g Set the POWER switch on the repair patchcord. h Remove all test cables and the repair patchcord. i Replace the control panel on the receiver-transmitter (para. 3-29).	a None. b None. c None d None e Waveform should appear. f When the rangemark is gated, the needle on the RANGE EXTENSION METERS meter must deflect to a minimum value. g None h None. i None

4-16. Testing the Audio System

The testing procedure required to check the serviceability of a repaired audio system when the components of the radar set are interconnected are described in paragraph 4-17.

4-17. Audio Gain Test

a. *Test Equipment and Materials*

- (1) Oscilloscope AN/USM-281.
- (2) Generator, Signal AN/URM-127.
- (3) Repair patch cord.
- (4) Control panel support fixture.

b. *Test Connection and Conditions.*

(1) Place the POWER switch on the AN/PPS-4A control panel at OFF.

(2) Disconnect all cables that are connected to the receptacles on the AN/PPS-4A control panel.

(3) Make the transmitter system accessible (para. 4-3b).

(4) Connect the power cable and headset cable to their respective receptacles on the control panel.

(5) Connect the signal output of the signal generator to jack J601 on the audio unit.

(6) Connect the AN/USM-281 across the output of the signal generator.

c. *Initial Test Equipment Calibration.* Calibrate the AN/USM-281 as indicated in the applicable instruction manual and the signal generator as outlined in TM 11-6625-683-15.

d. Test Procedure.

Step No.	Control settings		Test procedure	Performance standard
	Test equipment	Equipment under test		
1	Adjust the output of the AN/URM-127 to provide consecutive 80-, 400 and 1,000-Hz signals of 0.1-volt peak-to-peak amplitude as observed on AN/USM-281.	None.
2	Set the POWER switch on the AN/ PPS-4A control panel at TRANSMIT.	None.
3	After a delay of 90 seconds, listen for noise in the headsets.	The 80, 400 and 1,000 Hz tones must be audible in the headsets.
4	Set the POWER switch on the AN/ PPS-4A control panel at OFF.	None.
5	Disconnect all test equipment cables and the repair patchcord.	None.
6	Install the control panel on the receiver-transmitter (para. 3-59)	None.

4-18. Testing the Automatic Gain Control System

The receiver threshold test is performed to check the serviceability of a repaired agc system when the components are interconnected. This test checks the input signal level at which the radar set begins to decrease the gain of the IF amplifier unit. The threshold test of the age system is performed in conjunction with the complete system test procedures given in paragraphs 4-23 through 4-25.

4-19. Testing the Power Converter System

The testing procedures required to check a repaired power converter system when the components are interconnected are described in paragraphs 4-20 through 4-22.

4-20. RANGE EXTENSION METERS Meter Calibration for Battery Test

a. Test Equipment and Materials.

- (1) Multimeter TS-352B/U

(2) Control panel support fixture.

(3) Power Supply P1104C/G.

b. Test Connections and Conditions.

(1) Set the POWER switch on the AN/PPS-4A control panel at OFF.

(2) Make the transmitting system accessible (para. 4-3b).

(3) Connect the variable power supply to the 24 VDC BAT. ONLY receptacle J104 on the control panel.

(4) Connect the multimeter positive lead to terminal 6 of TB1 in the center section of the receiver-transmitter (fig. 8-13). Connect the negative lead to ground (terminal 7 of TB1).

c. Initial Test Equipment Calibration. Set the multimeter to measure voltage (TM 11-6625-366-15). Set the variable power supply for an output of exactly 24 volts (TM 11-6130-246-12).

d. Test Procedure.

Step No.	Control settings		Test procedure	Performance standard
	Test equipment	Equipment under test		
1	Caution: Make sure that the VOLT-AGE ADJ switch is in position 1 before setting the POWER switch at STANDBY, TRANSMIT, or RANGE. Place the POWER switch on the AN/ PPS-4A control panel to TRANSMIT.	None.
8	After a 90 second delay, observe the TS-352B/U indication.	The T5-32B/U must indicate +24±/ - 12 volt.

Step No.	Control settings		Test procedure	Performance standard
	Test equipment	Equipment under test		
3	Depress and hold the BATTERY TEST button on the AN/PPS-4A control panel. Use a screwdriver to adjust potentiometer R1005 on the strobe unit affixed to the rear of the control panel (fig. 3-8).	None
4	Observe the RANGE EXTENSION METERS meter needle while adjusting potentiometer R1005 of the red zone of the meter.	The RANGE EXTENSION METERS meter needle must be in the center
5	Release the BATTERY TEST button	None
6	Set the POWER switch on the AN/PPS-4A control panel at OFF.	None
7	Disconnect test equipment leads and repair patchcord.	None
8	Replace the control panel on the receiver-transmitter (para. 3-59).	None

4-21. Dc Output Test

a. Test Equipment and Material.

- (1) Voltmeter ME-30/U.
- (2) Multimeter TS352B/U.
- (3) Power Supply PP1104C/G.
- (4) Repair patch cord.
- (5) Control panel support fixture.

b. Test Connections and Conditions.

- (1) Set the POWER switch on AN/PPS-4A

control panel at OFF.

d. Test Procedures.

(2) Perform the procedures given in paragraph 4-3b (1) through (3).

(3) Connect the variable power supply to the 24 VDC BAT. ONLY receptacle.

c. Initial Test Equipment Calibration. Set the voltmeter (TM 11-6625-320-12) and multimeter (TM 11-6625-366-15) as in the applicable instruction manual. Set the variable power supply for an output of exactly 24 volts (TM 11-6130-24612).

Step No.	Control settings		Test procedure	Performance standard
	Test equipment	Equipment under test		
1	<p>CAUTION Make sure the voltages to be measured are well within the range of the selected voltmeter. Observe the polarity of the voltage to be measured and ground the appropriate voltmeter lead.</p> <ul style="list-style-type: none"> a Connect the test leads of TS-352B/U to measure the negative 150-volt output at terminal 10 of TB1. b Place the POWER switch on the AN/PPS-4A control panel at TRANSMIT. c Observe the TS-352B/U indication 	<ul style="list-style-type: none"> a None b None c The TS52B/U must indicate -145 to - 158.3 volts. d None
2	<ul style="list-style-type: none"> d Set the POWER switch on the AN/PPS 4A control panel at OFF. a Connect the leads of the TS-352B/U to measure the +120-volt output at terminal 5 of TB1. b Set the POWER switch on the AN/PPS-4A control panel at TRANSMIT. c Observe the TS352B/U indication 	<ul style="list-style-type: none"> a None b None c The T-362B/U must indicate between+114 and +126 volts.

Step No.	Control settings		Test procedure	Performance standard
	Test equipment	Equipment under test		
3	d. Set the POWER switch on the AN/PPS-L4A control panel at OFF. a. Ground the common lead of TS-352B/U and connect the other lead to terminal 6 of TB1. Select the proper meter range to measure +24 volts. b. Set the POWER switch on the AN/PPS-4A control panel at TRANSMIT. c. Observe the TS-35,2B/U indication	d. None. a. None. b. None. c. The TS-352B/U must indicate +22.8 to +25.2 volts. d. None.
4	d. Set the POWER switch on the AN/PPS-IA control panel at OFF. a. Connect TS-35rIB/U leads to measure the negative 20 volt output at terminal 9 of TB1. b. Set the POWER switch on the AN/PPS-4A control panel at TRANSMIT and vary the VOLTAGE ADJ switch until depression of the BATTERY TEST switch causes the calibrated RANGE EXTENSION METERS meter needle to indicate exactly in the center of the red zone. c. Observe the TS-352B/U indication d. Set the POWER switch on the AN/PPS-4A control panel at OFF. e. Remove all test equipment leads and the repair patch cord. f. Replace the control panel on the receiver-transmitter (para. 3-59).	d. None. a. None. b. None. c. The TS-352B/U must indicate -19 to-21 volts. d. None. e. None. f. None.

4-22.Ac Output Test

- a. *Test Equipment and Material.*
 - (1) Multimeter TS-352B/U.
 - (2) Power Supply PP1104C/G.
 - (3) Repair patch cord.
 - (4) Control panel support fixture.
- b. *Test Connections and Conditions.*
 - (1) Set the POWER switch on the AN/PPS-4A control panel at OFF.

- (2) Perform the procedures given in paragraph 4-3b (1) through (3).
- (3) Connect the variable power supply to the 24 VDC BAT. ONLY receptacle.
- c. *Initial Test Equipment Calibration.* Set up the TS-352B/U (TM 11-6625-366-15) as indicated in the applicable instruction manual. Set the variable power supply for an output of exactly 24 volts (TM 11-6130-246-12).
- d. *Test Procedure.*

Step No.	Control settings		Test procedure	Performance standard
	Test equipment	Equipment under test		
1	a. Connect the TS-352B/U leads across terminals 13 and 14 of TB1. b. Set the POWER switch on the AN/PPS-4A control panel at TRANSMIT and vary the VOLTAGE ADJ switch until	a. None. b. None.

Step No.	Control settings		Test procedure	Performance standard
	Test equipment	Equipment under test		
2	depression of the BATTERY TEST switch causes the calibrated RANGE EXTENSION METERS meter (para. -8) to indicate exactly in the center of the red zone. c. Observe the TS-352B/U indication. d. Set the POWER switch on the AN/PPS-4A control panel at OFF. a. Connect the TS-352B/U leads across terminal 11 and 12 of TB1. b. Set the POWER switch on the AN/PPS-4A control panel at TRANSMIT. c. Observe the TS-352B/U indication	c. The TS-352B/U must indicate between 6.65 and 7.36 volts rms. d. None. a. None b. None.
3	d. Set the POWER switch on the AN/PPS-4A control panel at OFF. a. Connect the TS-352B/U lead between pin 5 of switch S106 and ground. b. Set the POWER switch on the AN/PPS-4A control panel at TRANSMIT. c. Observe the TS-352B/U indication d. Set the POWER switch on the AN/PPS-4A control panel at OFF. e. Remove the test leads and the repair patchcord. f. Replace the control panel on the receiver-transmitter (para. 3-59).	c. The TS-362B/U must indicate between 6.11 and 6.62 volts rms. d. None a. None. b. None c. The TS-352B/U must indicate between 2.43 and 2.97 volts rms. d. None. e. None. f. None

4-23. Radar Set AN/PPS 4A, Complete Testing Procedure

The following chart lists the testing procedures that should be performed to test the operation of Radar Set AN/PPS-4A. Step-by-step directions for performing the procedures listed in the test column are contained in the paragraph listed in the procedure column. Perform the procedures in the order listed below.

<i>Test</i>	<i>Procedure</i>
Magnetron filament voltage test -----	Para. 4-3
Receiver threshold test-----	Para. 4-24
Afc system performance test -----	Para. 4-10
Trigger output test-----	Para. 4-4
Magnetron current and trigger output--- pulse tests	Para. 4-5
Pulse width, repetition rate, and power- output tests.	Para. 4-6
Short strobe test	Para. 4-12

Test Procedure

Long strobe test-----	Para. 4-13
Range gate test -----	Para. 4-14
Detector test -----	Para. 4-15
Audio gain test-----	Para. 4-17
Receiver sensitivity test -----	Para. 4-8
Doppler sensitivity test-----	Para. 4-25

4-24. Receiver Threshold Test

- a. *Test Equipment and Materials.*
 - (1) Oscilloscope AN/USM-281.
 - (2) Test Set, Radar TS-147D/UP.
 - (3) Repair patch cord.
 - (4) Plugs for tip jacks.
 - (5) Control panel support fixture.
- b. *Test Connection and Conditions.*
 - (1) Set the POWER switch on the AN/PPS-4A control panel to OFF.
 - (2) Make the transmitter system accessible (para. 4-3b).

(3) Connect the AN/USM-281 probe to jack J403 on the range unit (fig. 3-55).

c. *Initial Test Equipment Calibration.* Calibrate the AN/USM-281 as indicated in the applicable instruction

manual. Calibrate the TS-147D/UP as indicated in TM 11-1247B.

d. *Test Procedure.*

Step No.	Control settings		Test procedure	Performance standard
	Test equipment	Equipment under test		
1	Set the POWER switch on the AN/PPS-4A to TRANSMIT.	None.
2	Synchronize the AN/USM-281 to the radar set by using jack J401 on the range unit as an external trigger.	None.
3	Turn the RANGE CONTROL hand-wheel until a reading of greater than 3,000 meters is obtained on the RANGE METERS indicator.	None.
4	Remove the AN/USM-281 probe from jack J403 on the range unit and ground it to establish a ground reference on the AN/USM-281.	None.
5	Return the AN/USM-281 probe to jack J403 on the range unit and set the AN/USM-281 input control for ac input.	None.
6	Adjust the VOLUME control on the control panel until the baseline of the noise waveform on the AN/USM-281 is 0.2 volt above the ground reference.	None.
7	Remove the cover plate from the directional coupler access hole in the receiver-transmitter housing and unscrew the cap on the directional coupler cable assembly.	None.
8	Connect the output cable of the TS-147D/UP to the directional coupler cable assembly jack J908.	None.
9	Observe the AN/USM-01 scope indication.	The AN/USM-291 must indicate a signal with an amplitude of 1.3 to 1.7 volt.
10	Disconnect all test equipment cables from the receiver-transmitter.	None.
11	Replace the control panel on the receiver-transmitter (para. 3-59).	None.

4-25. Doppler Sensitivity Test

a. *Test Equipment and Material.*

- (1) Oscilloscope AN/USM-281.
- (2) Range Calibrator AN/UPM-11A.
- (3) Generator Signal AN/URM-127.
- (4) Control panel support fixture.
- (5) Repair patch cord.

b. *Test Connections and Conditions.*

(1) Place the POWER switch on the AN/PPS-4A control panel at OFF.

(2) Make the transmitter system accessible (para. 4-3b).

(3) Remove the cover from the directional coupler J908 access hole in the receiver-transmitter housing.

(4) Unscrew the cap of the directional coupler cable assembly.

(5) Connect the RF cable of the range calibrator to jack J908 in the access hole.

c. *Initial Test Equipment Calibration.* Calibrate the oscilloscope as indicated in the applicable instruction manual. Operate the range calibrator as described in TM 11-6625-310-15.

d. Test Procedure.

Step No.	Control settings		Test procedure	Performance standard
	Test equipment	Equipment under test		
1	Connect the probe of the AN/USM-281 to jack J403 (fig. 3-65) on the range unit using a tip jack plug. Use the output at jack J401 of the range unit as an external trigger for synchronizing the AN/USM-281 to the radar set.	None.
2	Turn the RANGE CONTROL handwheel until a reading of greater than 38,000 meters is obtained on the RANGE METERS indicator.	None.
3	Remove the AN/USM-281 probe from jack J403 on the range unit and ground it to establish a ground reference on the AN/USM-281.	None.
4	Return the probe to jack J403 of the range unit, and set the AN/USM-281 input control for ac input.	None.
5	Tune the AN/UPM-11A to the operating frequency of the radar set according to instructions given in TM 11-6625-310-15 until reference on the AN/USM-281. 127 appears on the AN/USM-281.	None.
6	Observe the first rangemark and make sure that it is not being gated.	None.
7	Reduce the level of the first rangemark to approximately 3/4 of its level limit by adjusting the VOLUME control on the control panel.	None.
8	Connect the AN/URM-127 to the external modulator input jack on AN/UPM-11A, and adjust the AN/URM-127 for minimum output at a frequency of 100 Hz.	None.
9	Measure the amplitude E, of the unmodulated first rangemark on the AN/USM-81.	Peak-to-peak modulation on top of the rangemark must be 0.1 E.
10	Adjust the output control of the AN/URM-127 until the peak-to-peak modulation on top of the rangemark is 0.1.	None.
11	Adjust the VOLUME control on the control panel until the noise level (baseline of the waveform) is shifted by approximately 0.3 volt.	None.
12	Gate the first rangemark by turning the RANGE CONTROL handwheel and observing the needle of the RANGE EXTENSION METERS meter.	Minimum leftward deflection of the RANGE EXTENSION METERS meter needle should be observed.
13	Listen for audio tones in the headsets while rocking the AN/URM-127 frequency a few Hz from its original setting.	Audio tones must be audible in the headsets.
14	Repeat 9 through 11 above twice using AN/URM-127 frequencies of 400 and 1,000 Hz	Audio tones must be audible in the headsets indicating a doppler sensitivity of 5% or less.

CHAPTER 5

GENERAL SUPPORT MAINTENANCE

Section I. GENERAL

5-1. Scope of Maintenance

The general support maintenance procedures in this chapter supplement the procedures for direct support maintenance (ch. 3). General support procedures include troubleshooting, alignment adjustment, removal, replacement, and repair of the radar set components not repairable at the direct support level.

5-2. Tools and Test Equipment Required

Refer to the basic issue items list (BIL) and maintenance allocation chart (MAC) in TM 11-5840-211-12 for a complete list of tools and test equipment authorized for general support maintenance. Special test equipment required to maintain the radar set is listed in chapter 3.

Section II. GS TROUBLESHOOTING

5-3. Scope of Troubleshooting

General support troubleshooting includes all direct support troubleshooting procedures plus isolation of the trouble to a specific part or circuit in the radar set.

a. General Instructions and Precautions. The general support troubleshooting charts are a continuation of the direct support troubleshooting charts. Direct support general instructions and general precautions apply also to general support maintenance.

b. Organization of Troubleshooting Procedures. Troubleshooting procedures contained in this section supplement procedures performed at lower categories of maintenance plus isolation of trouble to any circuit or component in the radar set. Troubleshooting charts located in this section are-

- (1) Troubleshooting based on starting procedures (para. 5-7).
- (2) Transmitting systems (para. 5-8).
- (3) Receiving system (para. 5-9).
- (4) Automatic frequency control systems (para. 5-10).
- (5) Ranging system (para. 5-11).
- (6) Audio system (para. 5-12).
- (7) Automatic gain control system (para. 5-13).
- (8) Power converter system (para. 5-14).

c. Supplementary Troubleshooting Data. In addition to the troubleshooting charts listed in b above, additional troubleshooting procedures are provided for the units, stages, and circuits listed below.

- (1) IF amplifier unit (para. 5-15).
- (2) Transistor Q505 stage (para. 6-16).
- (3) Transistor Q504 stage (para. 5-17).
- (4) Transistor Q503 stage (para. 5-18).
- (5) Transistor Q502 stage (para. 5-19).
- (6) Transistor Q501 stage (para. 5-20).
- (7) Blanking pulse subchassis (para. 5-21).
- (8) Afc search and control circuit (para. 5-22).
- (9) Afc unit (para. 5-23).
- (10) Range unit (para. 5-24).
- (11) Strobe circuit (para. 5-25).
- (12) Audio amplifier circuit (para. 5-26).

5-4. Reference Designations

To aid in parts location, a block of reference designation numbers has been assigned to each unit of Radar Set AN/PPS-4A. *For example*, all parts on the transmitter unit are numbered from 201-299; that is, resistors in this unit are designated R201, R202, etc., and capacitors designated C201, C202, etc. The following chart lists the block of reference designation numbers assigned to each unit.

<i>Reference designation numbers</i>	<i>Units</i>
101-199 -----	Control
201-299 -----	Transmitter
401-499 -----	Range
501-599 -----	IF amplifier
601-699 -----	Audio
701-799 -----	Afc
801-899 -----	Power converter
901-999 -----	Microwave
1001-1099 -----	Strobe

5-5. Transistor and Diode Testing

a. Triode and tetrode transistors and Zener diodes should be tested while connected in the circuit. If a transistor is suspected of being defective, test it with Test Set, Transistor TS-1836/U (TM 11-6625-539-15). If a transistor is defective, replace it (para. 5-6).

b. When soldering transistors, use a pencil-type soldering iron with a 25-watt maximum capacity. Do not use a soldering gun; damaging voltages can be induced in circuit components.

c. When soldering transistor leads, solder quickly; whenever wiring permits, use a heat sink (such as a long-nosed pliers) between the soldered joint and the transistor.

5-6. Transistor Replacement

With the exception of transistors Q801 and Q802 in the power converter unit, and Q204, Q205

, and S dulator of the transmitter unit, all transistors in the radar set are mounted on circuit boards. The replacement procedure for transistors Q801 and Q802 is given in paragraph 5-35. To remove transistors mounted on circuit boards, proceed as follows:

a. Remove the circuit board from its case, following the procedures outlined in the appropriate system troubleshooting and repair chapter.

b. Remove the epoxy coating from the transistor terminals on the underside of the circuit board.

c. Unsolder the transistor by heating the transistor terminals simultaneously, and remove the transistor and its Supporting Teflon spacer from the circuit board.

NOTE

Teflon spacers are not used in the IF amplifier unit.

d. The leads of the new transistor should be cut so that the transistor is approximately 3/8 inch above the circuit board and is supported by the Teflon spacer.

e. Solder the transistor to the circuit board using a heat sink (such as long-nosed pliers) between the soldered joint and the transistor, wherever wiring permits.

5-7. Troubleshooting Chart Based on Starting Procedures

Item	Trouble symptom	Probable trouble; checks; and corrective measures
1	RANGE EXTENSION METERS meter needle indicates zero or below half-scale deflection when the POWER switch is at TRANSMIT, STROBE switch is at OFF, the VOLUME ADJ switch is at position 1 and the BATTERY TEST button is depressed after a delay of 90 seconds.	Defective meter M101. Replace meter.
2	RANGE EXTENSION METERS meter needle does not advance from 0+50-10 meter to 500 +10-50 meters in 4 to 6 seconds when the POWER switch is at TRANSMIT, STROBE switch is at SHORT, and RANGE METERS indicator is set to approximately 5,000 meters.	a. Defective STROBE switch S105. Replace switch. b. Defective meter M101. Replace meter.
3	RANGE EXTENSION METERS meter needle does not advance from 0+50-10 meters to 500+50-10 meters in 8 to 12 seconds when the POWER switch is at TRANSMIT, the STROBE switch is at LONG, and the RANGE METERS indicator is set to approximately 6,000 meters.	Same as Item 2.

Item	Trouble symptom	Probable trouble; checks: and corrective measures
4	RANGE EXTENSION METERS meter and RANGE METERS indicator lamps do not light or vary in brightness when the PANEL LIGHTS switch is rotated clockwise.	Defective resistor R104 or control knob. Replace R104 or control knob.
5	Tripod lamps do not light or vary in brightness when the TRIPOD LIGHTS switch is rotated clockwise.	Defective resistor R103 or control knob. Replace R106 or control knob.
6	Telescope reticule does not illuminate when the TELESCOPE LIGHT button is depressed.	Defective TELESCOPE LIGHTS switch S103. Replace switch.
7	No waveform, or range gate waveform does not move when the STROBE switch is at OFF, oscilloscope is connected to jack J404 on the range unit, and the RANGE CONTROL hand-wheel is rotated.	a. Defective potentiometer R103. Replace potentiometer R103. b. Defective potentiometers R101, R102 and R107 or resistor R108. Replace R101, R102, R107 or R108.

5-8. Transmitting System Troubleshooting Chart

Item	Trouble symptom	Probable trouble; checks: and corrective measures
1	Warning: Extremely dangerous voltages exist in the transmitting system of Radar Set AN/PPS-4A. High voltages are developed in pulse unit Z201, on magnetron V801, and on the cable connecting the magnetron with the pulse unit. No waveform (A, fig. 3-111) at pin 2 of modulator A201 on the transmitter unit with POWER switch at TRANSMIT and STROBE switch at OFF.	a. Defective relays K201 or K202. Replace K201 or K202. b. Defective modulator A201. Replace A201.
2	No waveform (B, fig. 3-11) at J203 on the transmitter unit with POWER switch at TRANSMIT and STROBE switch at OFF	a. Defective diode CR203. Replace CR203. b. Defective capacitor C216. Replace C216. c. Defective transformer or winding in pulse unit Z201. Replace transformer or winding in Z201. d. Defective modulator A201. Replace A201 and check for waveform at J203. If waveform is not observed at J203, proceed to e below. e. Defective pulse unit Z201. Replace Z201.
3	Pulse width is greater than or less than 0.2 ± 0.02 sec at 50% points at directional coupler J908 (fig. 3-1) with POWER switch at TRANSMIT and STROBE switch at OFF.	Defective pulse unit Z201. Replace Z201.
4	No waveform (C, fig. 3-11) at junction of ORM5 and C205 (fig. 3-14) on the rear of the circuit board with POWER switch at TRANSMIT and STROBE switch at OFF.	a. Defective transistor Q201. Check Q201; replace if defective. b. Defective pulse unit Z201. Check output at jack w206 (fig. 3-14) with oscilloscope. A negative waveform (54 to 70 volts in amplitude) should be present. If waveform is not present, replace Z201 (para. 3-14).

5-9. Receiving System Troubleshooting Chart

Item	Trouble symptom	Probable trouble; checks: and corrective measures
1	Current at only jack J506 or J507 on the IF amplifier unit with POWER switch at TRANSMIT.	a. Defective capacitors C649, C50, 0503 or inductors L511, L502, and L501 (fig. 3-16). Check C549, C504, C503, L511, L502, and L501; replace if defective. b. Defective capacitors C50, 0506, 0505 or inductors L513, L504, and L503 (fig. 3-16). Check C550, C506, C505, L513, L604, and L503; replace if defective.

5-10. Automatic Frequency Control Troubleshooting Chart

Item	Trouble symptom	Probable trouble; checks; and corrective measures
1	<p>Note. Whenever components of the afc system are replaced the afc sweep adjustment, klystron and magnetron tuning adjustments, testing procedures for the afc system and range calibration adjustment procedures must be performed.</p> <p>Multimeter does not measure -70 to -145 volts between jack J604 on the audio unit (fig. 3-68) and ground with POWER switch at TRANSMIT and AFC/MFC switch on the audio unit at MFC.</p>	Defective afc search and control circuit in the audio unit. Troubleshoot the afc search and control circuit in the audio unit (para. 5-22).
2	Multimeter indication does not vary between -70 and -146 volts at approximately 5 Hz when measured between jack J604 on the audio unit (fig. 3-58) and ground with the POWER switch at STANDBY and the AFC/MFC switch on the audio unit at AFC.	Same as 1 above.
3	Afc error pulse (B, fig. 3127) not observed on oscilloscope as measured at jack J701 on the AFC unit (fig. 3-59) with POWER switch at TRANSMIT and AFC/MFC switch on the audio unit at MFC.	Defective afc unit. Troubleshoot the afc unit as outlined in para. 5-23.

5-11 . Ranging System Troubleshooting Chart

Item	Trouble symptom	Probable trouble; checks; an corrective measures
1	RANGE EXTENSION METERS meter needle does not deflect to a minimum value near 500 meters and at approximately every 1,000 meters thereafter as RANGE CONTROL handwheel is varied from 1 to 7,500 meters with POWER switch at RANGE, STROBE switch at OFF, and VOLUME control rotated completely clockwise.	<p>a. Defective strobe circuit. Refer to troubleshooting strobe circuit (para. 5-25).</p> <p>b. Defective range unit Refer to troubleshooting the range unit (para. 5-24).</p>
2	Waveform (A, fig. 3-27) not present on oscilloscope as measured at jack J603 on the audio unit with POWER switch at RANGE, RANGE METERS indicator at 500, and STROBE switch at OFF.	Defective transformer T401 in the range unit. Refer to the audio amplifier circuit troubleshooting procedures (para. 5-26).
3	Waveform (B, fig. 345) not observed on oscilloscope at jack J4-2 on the range unit with POWER switch at RANGE, RANGE METERS indicator at 500, and STROBE switch at OFF.	Defective strobe unit. Refer to troubleshooting the strobe circuit (para 6-25).
4	Voltage of 3.75 vdc not measured at jack J406 on the range unit with POWER switch at RANGE, RANGE METERS indicator at 500, and STROBE switch at OFF	Defective diodes CR40S and Check CR406 and CR417 CR417 replace if defective.
5	Waveform (D, fig. 335) not observed on oscilloscope at jack J404 on range unit with POWER switch at TRANSMIT, RANGE METERS indicator at L range where no moving targets will be gated, and STROBE switch at OFF Waveform observed is similar to A, fig. 3-37.	Defective diodes CR405 and CR417 in the range unit. Replace CR405 and CR417 and check for +60 volts If present and waveform is dc at test point E422 not observed, refer to troubleshooting the range unit (para 5-24).

Item	Trouble symptom	Probable trouble; checks; an corrective measures
6	Waveform (D, fig. -35) not observed on oscilloscope at jack J404 on range unit with POWER switch at TRANSMIT, RANGE METERS indicator at a range where no moving targets will be gated, and STROBE switch at OFF. Waveform observed is similar to B, fig. 3-7.	<ul style="list-style-type: none"> a. No video input at jack J403. Refer to IF amplifier troubleshooting procedures (par 415). b. Defective capacitor C417. Replace C417.
7	Waveform (E, fig. 3-5) not observed on oscilloscope at jack J405 on the range unit with POWER switch at TRANSMIT, RANGE METERS indicator at a range where no targets will be gated, and STROBE switch at OFF.	Defective transistors Q407 and Q406 or diodes CR413 and CR414. Refer to troubleshooting the range unit (para. 524).

5-12. Audio System Troubleshooting Chart

Item	Trouble symptom	Probable trouble; checks; an corrective measures
1	Absence of rushing sound in headsets with POWER switch at TRANSMIT, STROBE switch at OFF, and radar set not gathering any large clutter	<ul style="list-style-type: none"> a. Defective audio amplifier circuit or audio transformer T1. Refer to audio amplifier circuit troubleshooting procedures (para. -28). b. Defective filters FL103 and FL104. Replace filters FL103 and FLA04 on control panel.
2	Abnormally distorted sounds In headset when moving targets are being gated with POWER switch at TRANSMIT and, STROBE switch at OFF.	Defective audio amplifier circuit. Refer to the audio amplifier troubleshooting procedure (para 5-26).

5-13. Automatic Gain Control System Troubleshooting Chart

Item	Trouble symptom	Probable trouble; checks; an corrective measures
1	Abnormal indication on RANGE EX TENSION METERS meter when POWER switch is at TRANSMIT, STROBE switch is at OFF and no TARGET IS BEING GATED. (Normal indications on the RANGE EXTENSION METERS meter are given in TM 11-5840-211-12).	<ul style="list-style-type: none"> a. Defective strobe circuit in the to corrective measures for troubleshooting the strobe circuit (para 5-26). b. Defective resistor R106 or R109 in control panel. Replace R105 or R109.
2	Dc voltage at jack J602 on the audio unit is not within the range of -2.5 volts and -5.5 volts when potentiometer R615 (threshold adjustment) is adjusted properly and VOLUME control is fully clockwise with POWER switch at TRANSMIT, STROBE switch at OFF, and RANGE METERS indicator set so no targets are being gated.	Defective transistor Q604 in the audio unit. Replace Q605.
3	Dc voltage at test point E612 in the audio unit is not within the range of -8 volts and -6 volts with POWER switch at TRANSMIT, STROBE switch at OFF, and RANGE METERS indicator set so no targets are being gated.	Defective transistor Q604 or diode CR602 in the audio unit. Check Q604, CR602, and associated circuit. Replace defective component or circuit.
4	Dc voltage at test point E610 on the audio unit is not approximately -1 volt when potentiometer R615 is fully counterclockwise with POWER switch at TRANSMIT, STROBE switch at OFF, and RANGE METERS indicator set so no targets are being gated.	<ul style="list-style-type: none"> a. Defective potentiometer R615. Replace R615. b. Defective transistor Q614 or diode CR602 Replace Q604 or CR602.

Item	Trouble symptom	Probable trouble; checks; an corrective measures
5	Dc voltage at jack J602 on the audio unit is not within the range of -2.6 and -4.5 volts with potentiometer R615 fully counterclockwise, VOLULME control fully clockwise, POWER switch At TRANSMIT, STROBE tch at OFF, and RANGE DETERS indicator at a point where no targets are being gated.	Defective potentiomeer R616. Replace R616.

5-14. Power Converter System Troubleshooting Chart

Item	Trouble symptom	Probable trouble; checks; an corrective measures
1	RANGE EXTENSION METERS meter,M101 indicates zero when BATTERY TEST switch S104 is depressed and POWER switch is in any position but OFF. No noise heard in headset when POWER switch is in TRANSMIT position.	<ul style="list-style-type: none"> a. Faulty VOLTAGE ADJ switch S102. Replace S102. b. Faulty BATTERY TEST switch S104. Replace S104. c. Defective transistors Q801, Q802.. Check Q801 and Q802 ; Replace R801, R802, R805, and R809. d. Defective transistors Q801 and Q802. Check Q801 and Q802; replace if defective (para 5-35). e. Short to ground or defective diodes CR801 through CR813. Set POWER switch at OFF and check for shorts to ground in the radar set across power converter unit voltage output terminals. Set POWER switch at TRANSMIT and recheck output voltages If output voltages remain low and Q801 or Q802 were replaced, set POWER switch at OFF and check diodes CR801 through CR813; trouble which caused the transistors to become defective may have also affected some of the diodes. Diodes CR801 through CR813 are checked by unsoldering one lead of a diode and measuring its forward and backward resistance with a multimeter. If forward resistance is more than 500 ohms or is backward resistance is les than 50K, diode must be replaced. After replacing any defective diodes, check associated leads and circuits for shorts to ground before resetting POWER switch at TRANSMIT.
2	POWER FUSE F102 continues to blow -----	<ul style="list-style-type: none"> a. Overload or short in power converter. Check the power converter unit for shorts to ground; replace faulty components. b. Defective transistors Q801 and Q802. Check Q801 and Q802; replace if defective (para 5-35).
3	RANGE EXTENSION METERS meter indicates above red zone when BATTERY TEST switch is depressed.	Shorted primary transformer T801. Replace T801. Check range extension meters meter calibration for battery test.
4	Positive 270 volts not present at terminal of 4 of TB1 fig. 3-13) with POWER switch at TRANSMIT	<ul style="list-style-type: none"> a. Capacitor C807 or leads are open. Replace C807 b. Defective diodes CR809 and CR810. Replace CRB809 and CR810. c. Defective capacitor C6 on center section. Replace C6. d. Defective reactor L1 on center section. Replace L1.
5	Negative 140 to 158 volts not measured at terminal 10 of TB 1(fig. 3-13) with POWER switch at TRANSMIT.	<ul style="list-style-type: none"> a. Defective capacitors C805, C806 or leads. Replace C805, C806 or leads b. Defective diodes CR807 and CR808 Replace CR807 and CR808.
6	Positive 114 to 126 v. not measured at terminal 5 of TB1 (fig. 3-13) with POWER switch at TRANSMIT.	<ul style="list-style-type: none"> a. Defective capacitor C804. Replace C804. b. Defective diodes CR805 or CR806. Replace CR805 or CR806

Item	Trouble symptom	Probable trouble; checks; an corrective measures
7	Positive 24 \pm 1.2 volts not measured at terminal 6 of TB1 (fig. 3-13) with POWER switch at TRANSMIT.	a. Defective capacitor C802. Replace C802. b. Defective diodes CR803 or CR804. Replace CR80S or CR804.
8	Negative 20 \pm 1 volts not measured at terminal 9 of TB1 (fig. 3-13) with POWER switch at TRANSMIT.	a. Defective capacitor C801. Replace C801. b. Defective diodes CR801 and CR802. Replace CR801 or CR802.
9	Ripple voltage exceeds 0.3 peak-to-peak as observed on oscilloscope connected between pin 4 of TB1 (fig. 3-13) and ground with POWER switch at TRANSMIT	Same as item 4
10	Ripple voltage exceeds .4 peak-to-peak as observed on oscilloscope connected between terminal 10 or TB1 (fig. 3-13) and ground with POWER switch at TRANSMIT and after a delay of 90 seconds.	Same as item 5
11	Ripple voltage exceeds 1.5 peak-to-peak as observed on oscilloscope connected between terminal 5 and ground with POWER switch at TRANSMIT and after a delay of 90 seconds.	Same as item 6
12	Ripple voltage exceeds .4 P-to-P observed on oscilloscope connected between terminal 6 and ground with POWER switch at TRANSMIT and after a delay of 90 seconds.	Same as item 7
13	Ripple voltage exceed .4 peak-to-peak as observed on oscilloscope connected between terminal 9 of TB1 and ground with POWER switch at TRANSMIT and after a delay of 90 seconds	Same as item 8
14	With oscilloscope connected between terminal 11 and 12 of TB1, 12 to 13.2 volts peak-to-peak not observed with POWER switch at TRANSMIT and after a delay of 90 seconds.	Defective secondary of transformer T801. Check secondary for shorts. Replace T801 if defective.
15	With oscilloscope connected across terminals 13 and 14 of TB1, 13 to 14.5 volts peak-to-peak not observed on oscilloscope with POWER switch at TRANSMIT and after a delay of 90 seconds.	Same as item 14
16	With multimeter connected across contact 5 of switch S106 and ground, 2.7 \pm 0.27 volts rms not measured with POWER switch at TRANSMIT and after a delay of 90 seconds.	Same as item 14

5-15. IF Amplifier Troubleshooting

a. Set up test equipment for the bandwidth and gain adjustment (para. 3-36). Adjust the sweep generator to obtain an output of 0.43 volt at the terminated test cable as measured with the vacuum tube voltmeter. Disconnect the terminated test cable from the

step attenuator. Connect the BNC coaxial cable between the step attenuator and the input jack on the dummy mixer. Connect plugs P504 and P505 to the output jacks on the

dummy mixer (fig. 3-47). Set the POWER switch at TRANSMIT. Adjust the step attenuator to obtain a response of approximately 0.5 volt on the oscilloscope. The attenuation should be 85 db or greater and the bandpass response curve should resemble that shown in F, figure 3-46. If the above conditions are not obtained, proceed as follows:

(1) Disconnect the dummy mixer from the step attenuator and the IF amplifier unit. Connect the terminated test cable between the step attenuator and the cold side of capacitor C653. Adjust the step attenuator and/or the attenuators on the sweep generator to obtain a response of approximately 0.1 volt on the oscilloscope. The response curve will be practically a straight line.

NOTE

The cold side of the capacitor is the side closest to ground potential and is indicated as the curved side on the schematic symbol for a capacitor.

(2) Note the vertical deflection on the oscilloscope.

(3) Connect the terminated test cable to the cold side of capacitor C526. Connect a 1,000cAlf capacitor between the cold side of capacitor C524 and ground. Connect the clip on one side of the 1,000-,uif capacitor to the cold side of capacitor CG524, and connect the clip on the other side of the 1,000-,tLf capacitor to a screw on the alignment cover.

(4) Insert attenuation into the circuit by means of the step attenuator and/or the attenuators on the sweep generator until the vertical deflection on the oscilloscope is the same as that noted in (2) above. The amount of additional attenuation inserted into the circuit to obtain the vertical deflection noted in (2) above is equal to the gain of the transistor Q505 stage. Note the gain. Set the output reference on the oscilloscope to approximately 0.5 volt by removing some attenuation in the step attenuator or varying the output of the sweep generator.

(5) Disconnect the 1,000,,f capacitor from the cold side of capacitor C524. Connect the terminated test cable to the cold side of capacitor C524. Connect the 1,000-l,)f capacitor between the cold side of capacitor C521 and ground.

(6) Insert attenuation into the circuit by means of the step attenuator and/or the attenuators on the sweep generator until the vertical deflection on the

oscilloscope is the same as that set in attenuation inserted into the circuit (4) above. The amount of additional attenuation to obtain the vertical deflection set in (4) above is equal to the gain of the transistor Q504 stage. Note the gain.

(7) Disconnect the 1,000-,A,f capacitor from the cold side of capacitor C521. Connect the terminated test cable to the cold side of capacitor C621'. Connect the 1,000-c,%l capacitor between the cold side of capacitor C51'5 and ground.

(8) Insert attenuation into the circuit by means of the step attenuator and/or the attenuators on the sweep generator until the vertical deflection on the oscilloscope is the same as that set in (4) above. The amount of additional attenuation inserted into the circuit to obtain the vertical deflection set in (4) above is equal to the gain of the transistor Q503 stage. Note the gain.

(9) Disconnect the 1,000-q,uf capacitor from the cold side of capacitor 051'5. Connect the terminated test cable to the cold side of capacitor C516. Connect the 1,000-,f capacitor between the cold side of capacitor 5i76 and ground.

(10) Insert attenuation into the circuit by means of the step attenuator and/or the attenuators on the sweep generator until the vertical deflection on the oscilloscope is the same as that set in (4) above. The amount of additional attenuation inserted into the circuit to obtain the vertical deflection set in (4) above is equal to the gain of the transistor Q502 stage. Note the gain.

(11) Disconnect the 1,000-lL-f capacitor from the cold side of capacitor C576. Connect the terminated test cable to the cold side of capacitor 0576.

(12) Insert attenuation into the circuit by means of the step attenuator and/or the attenuators on the sweep generator until the vertical deflection on the oscilloscope is the same as that set in (4) above. The amount of additional attenuation inserted into the circuit to obtain the vertical deflection set in (4) above is equal to the gain of the transistor Q501 stage. Note the gain.

(13) Set the POWER switch at OFF. Disconnect the terminated test cable from the step attenuator and from the cold side of capacitor C576.

Connect the BNC to BNC coaxial cable between the step attenuator and the input jack on the dummy mixer. Connect plugs P504 and P505 to the input jacks on the dummy mixer (fig. 3-7). Set the POWER switch at TRANSMIT.

(14) Insert attenuation into the circuit by means of the step attenuator and/or the attenuators on the sweep generator until the vertical deflection on the oscilloscope is the same as that

set in (4) above. The amount of additional attenuation inserted into the circuit to obtain the vertical deflection set in (4) above is equal to the gain of the IF signal preamplifier Q508 stage.

Note the gain.

(15) Observe the values of gain noted in (4), (6), (8), (10), (12), and (14) above. The nominal gain per transistor stage should be approximately 15 db. The nominal gain for the IF signal preamplifier stage is approximately 20 db.

NOTE

The nominal, total gain for the IF amplifier unit is 95 db. The acceptable limit for the gain is 85 db. Therefore, a total variation of 10 db may be obtained in the stages of the IF amplifier unit, and the IF amplifier unit would still be acceptable.

(16) If it is determined in (15) above that one or more stages have a very low gain, proceed as follows:

(a) Readjust the stage which has the low gain, and all the stages preceding it as directed in paragraph (3-41).

(b) With the transistor tester, check the transistor, contained in the stage which has the low gain, and replace if necessary. If the IF signal preamplifier stage has low gain, check IF signal preamplifier Q508.

(c) Proceed to b below.

b. Set up test equipment for the bandwidth and gain adjustment (para. 336). Perform the first adjustment in the bandwidth and gain adjustment procedure (para. 3-41).

(1) If the response curve obtained on the oscilloscope is similar to that illustrated in A, figure 346 or A, figure 3-45, proceed to c below.

(2) If a response curve similar to that illustrated in A, figure 346 or A, figure 3-45 cannot be obtained on the oscilloscope, set the POWER switch at OFF and remove the oscilloscope connection and 33,000-ohm resistor from test point E2; disconnect - terminated test cable from the negative side of capacitor C526; disconnect the 1,000-iAf capacitor from capacitor C524; remove the nine binding head screws and nine lockwashers from the alignment cover; remove the alignment cover.

(a) Check diode CR501, capacitors C566, C567, inductors L533, L534, and resistors R6533, R534. Replace any defective components. Repeat b above.

(b) Set the POWER switch at TRANSMIT and perform the troubleshooting procedure for the transistor Q505 stage (para. 516).

(c) Check blanking circuit diodes CR502, CR503, CR504, and CR505 (para. 5-21) and replace if necessary.

c. Perform the second adjustment in the bandwidth and gain adjustment procedure (para. 337a and c).

(1) If the response curve obtained on the oscilloscope is similar to that illustrated in B, figure 3-46 or B, figure 3-45, proceed to d below.

(2) If a response curve similar to that illustrated in B, figure 3-46 or B, figure 3-45 cannot be obtained on the oscilloscope, set the POWER switch at OFF and remove the oscilloscope connection and 33,000-ohm resistor from test point E2; disconnect the terminated test cable from the cold side of capacitor C524; disconnect the 1,000i/f capacitor from capacitor C521; remove the nine binding head screws and nine lockwashers from the alignment cover; remove the alignment cover. Set the POWER switch at TRANSMIT. Perform the troubleshooting procedure for the transistor Q504 stage (para. 6-17).

d. Perform the third adjustment in the bandwidth and gain adjustment procedure (para. 337d).

(1) If the response curve obtained on the oscilloscope is similar to that illustrated in C, figure 3-46 or C, figure 3-45, proceed to e below.

(2) If a response curve similar to that illustrated in C, figure 346 or C, figure 345 cannot be obtained on the oscilloscope, set the POWER switch at OFF and remove the oscilloscope connection and 33,000-ohm resistor from test point E2; disconnect the terminated test cable from the cold side of capacitor C521; disconnect the 1,000-i/f capacitor from capacitor C51'5; remove the nine binding head screws and nine lockwashers from the alignment cover; remove the alignment cover. Set the POWER switch at TRANSMIT and perform the troubleshooting procedure for the transistor Q503 stage (para. 5-18).

e. Perform the fourth adjustment in the bandwidth and gain adjustment procedure (para. 337e).

(1) If the response curve obtained on the oscilloscope is similar to that illustrated in D, figure 3-46 or D, figure P24, proceed to f below.

(2) If a response curve similar to that illustrated in D, figure 3-46 cannot be obtained on the oscilloscope, set the POWER switch at OFF and remove the oscilloscope connection and 33,000-ohm resistor from test point E2; disconnect the terminated test cable

from the cold side of capacitor C516; disconnect the 1,000- μ f capacitor from capacitor 057,6; remove the nine binding head screws and nine lockwashers from the alignment cover. Set the POWER switch at TRANSMIT and perform the troubleshooting procedure for the transistor Q502 stage (para. 5-19)

f. Perform the fifth adjustment in the bandwidth and gain adjustment procedure (para. 337f).

(1) If the response curve obtained on the oscilloscope is similar to that illustrated in E, figure 3-46 or E, figure 3-45, proceed to *g* below.

(2) If a response curve similar to that illustrated in E, figure 3-46 or E, figure 3-45 cannot be obtained on the oscilloscope, set the POWER switch at OFF and remove the oscilloscope connection and 33,000-ohm resistor from test point E2; disconnect the terminated test cable from the cold side of capacitor C576; remove the nine binding head screws and nine lockwashers from the alignment cover; remove the alignment cover. Set the POWER switch at TRANSMIT and perform the troubleshooting procedure for the transistor Q501 stage (para. 5-20).

g. Perform the sixth adjustment in the bandwidth and gain adjustment procedure (para. 337g).

(1) If the response curve obtained on the oscilloscope is similar to that illustrated in F, figure 346 or F, figure 3-45, proceed to *h* below.

(2) If a response curve similar to that illustrated in F, figure 3-46 or F, figure 3-45 cannot be obtained on the oscilloscope, set the POWER switch at OFF and remove the oscilloscope connection and 33,000-ohm resistor from test point E2; remove the nine binding head screws and nine lockwashers from the alignment cover; remove the alignment cover.

h. If the correct response curves are obtained for the six adjustments in the bandwidth and gain adjustment procedure, proceed as follows:

(1) Check the base No. 1 to emitter voltage of transistor Q506. This voltage should be approximately 0.5 volt. If it is not, check transistor Q506 and replace if necessary; check resistors R524, R531, R538; check capacitor C535.

(2) If the base No. 1 to emitter voltage of transistor Q506 is 0.5 volt, check the collector voltage of transistor Q506. The collector voltage should be approximately 2.6 volts. If it is not, check transistor Q506 and replace if necessary; check inductor L540, resistors R525 and R530 and capacitor C577.

(3) Check the base No. 1 to emitter voltage of transistor Q507. This voltage should be approximately 0.5 volt. If it is not, check transistor Q507 and replace if necessary; check resistors R527 and R530.

(4) If the base No. 1 to emitter voltage of transistor Q507 is 0.5 volt, check the collector voltage of transistor Q507. The collector voltage should be approximately 15 volts. If it is not, check transistor Q507 and replace if necessary; check capacitor C537 for a short; check resistor R526.

5-16. Transistor Q505 Stage Troubleshooting

If a response curve similar to that illustrated in A, figure 3-46, or A, figure 345 cannot be obtained set the POWER switch at RANGE and check the voltage at the collector of transistor Q505.

a. If the collector voltage is approximately +20 volts, check the base No. 1 to emitter voltage of transistor Q505.

(1) If the base No. 1 to emitter voltage is approximately 0.5 volt, check the base No. 2 to emitter voltage.

(a) If the base No. 2 to emitter voltage is approximately 0 volt, check capacitors C558 and 0529 and replace if necessary. Check capacitors (3, C560, and C573 and replace if necessary. Check inductors li21 and 1538 and replace if necessary. Check transistor Q505 with the transistor tester and replace if necessary. Repeat the procedure in paragraph 5-15b.

(b) If the base No. 2 to emitter voltage is not approximately 0 volt, check resistor RS20 and replace if necessary. Check capacitor C532 and replace if necessary. Continuity check from resistor R520 to pin D of jack J501. Check transistor Q505 with the transistor tester and replace if necessary. Repeat the procedure in paragraph 5-15b.

(2) If the base No. 1 to emitter voltage is not approximately 0.6 volt, check resistor R518 and replace if necessary. Continuity check from resistor R'518 to pin H of jack J601. Check inductor L532 and replace if necessary. Check voltage across capacitor C547. If it is not approximately -20 volts, check capacitors C547 and C564 for a short; check resistor R522. If the voltage across capacitor 0547 is approximately -20 volts, check transistor Q505 with the transistor tester and replace if necessary. Repeat the procedure ,in paragraph 5-16b.

b. If the collector voltage of transistor Q505 is approximately 0 volt, check the voltage at terminal point 4 (fig. 3-15) on the IF amplifier unit circuit board.

(1) If the voltage at terminal point 4 is approximately 20 volts, replace inductor L526, and repeat the procedure in paragraph 5-15b.

(2) If the voltage at terminal point 4 is 0 volt, check the voltage at the junction of inductor L519 and capacitor C534.

(a) If the voltage here is approximately 20 volts, replace inductor L519 and repeat the procedure in paragraph 5-15b.

(b) If the voltage at the junction of inductor L519 and capacitor C534 is 0 volt, check the voltage at the junction of inductor L520 and capacitor C536.

(c) If the voltage here is approximately 20 volts, replace inductor L520 and repeat the procedure in paragraph 5-16b.

(d) If the voltage at the junction of inductor L520 and capacitor C536 is 9 volt, check resistor R523 and replace if necessary. Repeat the procedure in paragraph 5-15b.

(e) If resistor R523 is not defective, check transistors Q501, Q502, Q503, Q504, Q505, Q506, and Q507 by following the procedure given in c below.

(f) If the transistors are not defective, check capacitors C563, C548, C534, C530, C531, C559, C525, C562, C523, C519, 0561, and C516 for shorts.

c. If the collector voltage of transistor Q505 is approximately -20 volts check transistors Q501, Q502, Q503, Q504, Q505, Q506, and Q507 as follows:

(1) Set the POWER switch at OFF. Unsolder the collector lead of transistor Q507.

(2) Set the POWER switch at RANGE.

(3) Check the voltage at the junction of inductor L520 and resistor R523. If the voltage here is now approximately +20 volts, replace transistor Q507. Repeat the procedure in paragraph 5-15b.

(4) If the voltage at the junction of inductor L520 and resistor R523 is approximately 0 or -20 volts, resolder the collector lead of transistor Q507 and check transistors Q506, Q505, Q504, Q503, Q502 and Q501, one at a time, with the procedure used to check transistor Q507.

5-17. Transistor Q504 Stage Troubleshooting

If a response curve similar to that illustrated in B, figure 3-46 or B, figure 3-45 cannot be

obtained, check the voltage at the collector of transistor Q504.

a. If the collector voltage is approximately +20 volts, check the base No. 1 to emitter voltage of transistor Q504.

(1) If the base No. 1 to emitter voltage is approximately 0.5 volt, check the base No. 2 to emitter voltage.

(a) If the base No. 2 to emitter voltage is approximately 0 volt, check capacitors C557 and C527 and replace if necessary. Check capacitors C572 and C526 and replace if necessary. Check inductor L537 and replace if necessary. Repeat the procedure in paragraph 5-15a.

(b) If the base No. 2 to emitter voltage is not approximately 0 volt, check resistor R516 and replace if necessary. Check capacitor C528 and replace if necessary. Continuity check from resistor R516 to pin D of jack J501. Check transistor Q504 with the transistor tester and replace if necessary. Repeat the procedure in paragraph 5-15c.

(2) If the base No. 1 to emitter voltage is not approximately 0.5 volt, check resistor R514 and replace if necessary. Continuity check from resistor R514 to pin H of Jack J501. Check inductor L531 and replace if necessary. Check voltage across capacitor C546. If it is not approximately -20 volts, check capacitor C546 for a short; check resistor P519. If the voltage across capacitor C546 is approximately -20 volts, check transistor Q504 with the transistor tester and replace if necessary. Repeat the procedure in paragraph 5-15c.

b. If the collector voltage of transistor Q504 is approximately 0 volt, check the voltage at terminal point 5 (fig. 3-15) on the IF amplifier unit circuit board.

(1) If the voltage at terminal point 5 is approximately 20 volts, replace inductor L525 and repeat the procedure in paragraph 5-15c.

(2) If the voltage at terminal point 5 is 0 volt, check the voltage at terminal point 4 (fig. 3-15).

(a) If the voltage here is approximately +20 volts, replace inductor L518 and repeat the procedure in paragraph 5-15c.

(b) If the voltage at terminal point 4 is 0 volt, check the voltage at the junction of inductor L519 and capacitor C534.

(c) If the voltage here is approximately +20 volts, replace inductor L519 and repeat the procedure in paragraph 5-15c.

(d) If the voltage at the junction of inductor L519 and capacitor C534 is 0 volt, check

the voltage at the junction of inductor L520 and capacitor C536.

(e) If the voltage here is approximately +20 volts, replace inductor L520 and repeat the procedure in paragraph 5-15c.

(f) If the voltage at the junction of inductor L520 and capacitor C536 is 0 volt, check resistor R523 and replace if necessary. Repeat the procedure in paragraph 5-15c.

5-18. Transistor Q503 Stage Troubleshooting

If a response curve similar to that illustrated in C, figure 3-46 or C, figure 3-45 cannot be obtained, check the voltage at the collector of transistor Q503.

a. If the collector voltage is approximately +20 volts, check the base No. 1 to emitter voltage of transistor Q503.

(1) If the base No. 1 to emitter voltage is approximately 0.5 volt, check the base No. 2 to emitter voltage.

(a) If the base No. 2 to emitter voltage is approximately 0 volt, check capacitors C520 and C566 and replace if necessary. Check capacitors C571 and C524 and replace if necessary. Check inductor L536 and replace if necessary. Repeat the procedure in paragraph 5-15d.

(b) If the base No. 2 to emitter voltage is not approximately 0 volt, check resistor R512 and replace if necessary. Check capacitor C522 and replace if necessary. Continuity check from resistor R512 to pin D of jack J501. Check transistor Q503 with the transistor tester and replace if necessary. Repeat the procedure in paragraph 5-15d.

(2) If the base No. 1 to emitter voltage is not approximately 0.5 volt, check resistor R510 and replace if necessary. Continuity check from resistor R510 to pin H of jack J501. Check inductor L530 and replace if necessary. Check voltage across capacitor C545. If it is not approximately -20 volts, check capacitor C545 for a short; check resistor R515. If the voltage across capacitor C545 is approximately -20 volts, check transistor Q503 with the transistor tester and replace if necessary. Repeat the procedure in paragraph 6-15d.

b. If the collector voltage of transistor Q503 is approximately 0 volt, check the voltage at terminal point 6 (fig. 3-15) on the IF amplifier unit circuit board.

(1) If the voltage at terminal point 6 is approximately +20 volts, replace inductor L524 and repeat the procedure in paragraph 5-15d.

(2) If the voltage at terminal point 6 is 0 volt, check the voltage at terminal point 5.

(a) If the voltage here is approximately +20 volts, replace inductor L517 and repeat the procedure in paragraph 5-15d.

(b) If the voltage at terminal point 5 is approximately 0 volt, check the voltage at terminal point 4.

(c) If the voltage at terminal point 4 is approximately +20 volts, replace inductor L518 and repeat the procedure in paragraph 5-15d.

(d) If the voltage at terminal point 4 is 0 volt, check the voltage at the junction of inductor L519 and capacitor C534.

(e) If the voltage here is approximately +20 volts, replace inductor L519 and repeat the procedure in paragraph 5-15d.

(f) If the voltage at the junction of inductor L519 and capacitor C534 is 0 volt, check the voltage at the junction of capacitor C536 and inductor L520.

(g) If the voltage here is approximately +20 volts, replace inductor L520 and repeat the procedure in paragraph 5-15d.

(h) If the voltage at the junction of inductor L520 and capacitor C536 is 0 volt, check resistor R523 and replace if necessary. Repeat the procedure in paragraph 5-15d.

5-19. Transistor Q502 Stage Troubleshooting

If a response curve similar to that illustrated in D, figure 3-46 or D, figure 3-45 cannot be obtained, check the voltage at the collector of transistor Q502.

a. If the collector voltage is approximately +20 volts, check the base No. 1 to emitter voltage of transistor Q502.

(1) If the base No. 1 to emitter voltage is approximately 0.5 volt, check the base No. 2 to emitter voltage.

(a) If the base No. 2 to emitter voltage is approximately 0 volt, check capacitors C555 and C554 and replace if necessary. Check capacitors C570 and C521 and replace if necessary. Check inductor L535 and replace if necessary. Repeat the procedure in paragraph 5-15e.

(b) If the base No. 2 to emitter voltage is not approximately 0 volt, check resistor R508 and replace if necessary. Check capacitor C517 and replace if necessary. Continuity check from resistor R508 to pin D of jack J501. Check tran-

sistor Q502 with the transistor Tester and replace if necessary. Repeat the procedure in paragraph 5-15e.

(2) If the base No. 1 to emitter voltage is not approximately 0.5 volt, check resistor R507 and replace if necessary. Continuity check from resistor R607 to pin H of jack J501. Check inductor L629 and replace if necessary. Check the voltage across capacitor C544. If IF is not approximately -20 volts, check capacitor C544 for a short; check resistor R511. If the voltage across capacitor C544 is approximately -20 volts, check transistor Q502 with the transistor tester and replace if necessary. Repeat the procedure in paragraph 5-15e.

b. If the collector voltage of transistor Q502 is approximately 0 volt, check the voltage at terminal point 7 (fig. 3-1.5) on the IF amplifier unit circuit board.

(1) If the voltage at terminal point 7 is approximately +20 volts, replace inductor L523 and repeat the procedure in paragraph 5-15e.

(2) If the voltage at terminal point 7 is 0 volt, check the voltage at terminal point 6.

(a) If the voltage here is approximately +20 volts, replace inductor L516 and repeat the procedure in paragraph 5-16e.

(b) If the voltage at terminal point 6 is approximately 0 volt, check the voltage at terminal point 5.

(c) If the voltage at terminal point 5 is approximately +20 volts, replace inductor L517, and repeat the procedure in paragraph 5-15e.

(d) If the voltage at terminal point 5 is approximately 0 volt, check the voltage at terminal point 4.

(e) If the voltage at terminal point 4 is approximately +20 volts, replace inductor L518 and repeat the procedure in paragraph 5-15e.

(f) If the voltage at terminal point 4 is 0 volt, check the voltage at the junction of inductor L519 and capacitor C534.

(g) If the voltage here is approximately +20 volts, replace inductor L519 and repeat the procedure in paragraph 5-15e.

(h) If the voltage at the junction of inductor L519 and capacitor C534 is 0 volt, check the voltage at the junction of capacitor C536 and inductor L520.

(i) If the voltage here is approximately +20 volts, replace inductor L520 and repeat the procedure in paragraph 5-15e.

(j) If the voltage at the junction of inductor L520 and capacitor C536 is 0 volt, check

resistor R523 and replace if necessary. Repeat the procedure in paragraph 5-15e.

5-20. Transistor Q501 Stage Troubleshooting

If a response curve similar to that illustrated in E, figure 3-46 or E, figure 3-45 cannot be obtained, check the voltage at the collector of transistor Q501.

a. If the collector voltage is approximately +20 volts, check the base No. 1 to emitter voltage of transistor Q501.

(1) If the base No. 1 to emitter voltage is approximately 0.5 volt, check the base No. 2 to emitter voltage.

(a) If the base No. 2 to emitter voltage is approximately 0 volt, check capacitor C514 and replace if necessary. Check capacitors C513 and C515 and replace if necessary. Check inductor L539 and replace if necessary. Repeat the procedure in paragraph 5-15f.

(b) If the base No. 2 to emitter voltage is not approximately 0 volt check resistor R505 and replace if necessary. Check capacitor C516 and replace if necessary. Continuity check from resistor R505 to pin D of jack J501. Check transistor Q501 with the transistor tester and replace if necessary. Repeat the procedure in paragraph 5-15f.

(2) If the base No. 1 to emitter voltage is not approximately 0.5 volt, check resistor R503 and replace if necessary. Continuity check from resistor R503 to pin D of jack J201. Check inductor L514 and replace if necessary. Check voltage across capacitor C539. If it is not approximately -20 volts, check capacitor C539 for a short. If the voltage across capacitor C539 is approximately -20 volts, check transistor Q501 with the transistor tester and replace if necessary. Repeat the procedure in paragraph 5-15f.

b. If the collector voltage of transistor Q501 is approximately 0 volt, check the voltage at terminal point 8 (fig. 3-15) on the IF amplifier unit circuit board.

(1) If the voltage at terminal point 8 is approximately +20 volts, replace inductor L522 and repeat the procedure in paragraph 5-15f.

(2) If the voltage at terminal point 8 is 0 volt, check the voltage at terminal point 7.

(a) If the voltage here is approximately +20 volts, replace inductor L515 and repeat the procedure in paragraph 5-15f.

(b) If the voltage at terminal point 7 is approximately 0 volt, check the voltage at terminal point 6.

(c) If the voltage at terminal point 6 is approximately +20 volts, replace inductor L516 and repeat the procedure in paragraph 5-15f.

(d) If the voltage at terminal point 6 is approximately 0 volt, check the voltage at terminal point 5.

(e) If the voltage at terminal point 5 is approximately +20 volts, replace inductor L517 and repeat the procedure in paragraph 5-15f.

(f) If the voltage at terminal point 5 is approximately 0 volt, check the voltage at terminal point 4.

(g) If the voltage at terminal point 4 is approximately +20 volts; replace inductor L518 and repeat the procedure in paragraph 5-15f.

(h) If the voltage at terminal point 4 is 0 volt, check the voltage at the junction of inductor L1519 and capacitor C534.

(i) If the voltage here is approximately +20 volts, replace inductor L519 and repeat the procedure in paragraph 5-15f.

(j) If the voltage at the junction of inductor L519 and capacitor C534 is 0 volt, check the voltage at the junction of capacitor C536 and inductor L520.

(k) If the voltage here is approximately +20 volts, replace inductor L520 and repeat the procedure in paragraph 5-15f.

(1) If the voltage at the junction of inductor L520 and capacitor C536 is 0 volt, check resistor R523 and replace if necessary. Repeat the procedure in paragraph 5-15f.

5-21. Blanking Pulse Sub-chassis Troubleshooting

a. Remove the blanking pulse sub-chassis as described in paragraph 5-30.

b. Perform a continuity check on the blanking pulse sub-chassis.

c. Check the resistors and capacitors in the blanking pulse sub-chassis. Replace defective components.

d. Unsolder one side of diodes CR502, CR'503 on the IF amplifier unit, and CR507 on the blanking pulse sub-chassis. With a multimeter, measure the front-to-back ratio for each diode. If the diode is not defective, a low resistance should be observed in one direction and, when the multimeter leads are reversed, a relatively high resistance should be observed on the multimeter. Replace any defective diodes.

e. Replace the blanking pulse sub-chassis, the IF amplifier unit as described in paragraph 5-30.

5-22. Afc Search and Control Circuit Troubleshooting

a. *General.* The afc search and control circuit is located on the audio unit in the lower portion of the center section of the receiver-transmitter f (fig. 3-13).

b. *Preparation.*

(1') Remove the audio unit from the receiver-transmitter mounting plate (para. 3-4).i

(2) Remove the five binding head screws and five lockwashers that fasten the cover on the audio unit, and remove the cover (fig. 3-58).

(3) Connect plug P601 on the audio unit to jack J601 on the receiver-transmitter mounting plate (fig. 3-60) by means of the audio bench test cable.

c. *Procedure.*

(1) Set the POWER switch at STANDBY, and AFC/MFC switch S601 at MFC. Using a multimeter, measure the voltage between test points E621 (positive) and E601. If the voltage is between +7.5 and + 10 volts, proceed to (4) below. If the voltage is not between +7.5 and +10 volts, proceed to (2) below.

(2) Check if AFC/MFC switch S601 is operative. Replace if necessary.

(3) Check diode CR608 and Capacitor C610. Replace if necessary. Proceed to (4) below.

(4) Measure the voltage between test point E604 and E601. If voltage is between +2 and +5 volts proceed to (6) below. If the voltage is not between +2 and +5 volts proceed to (5) below.

(5) Check potentiometer R632, diode CR 607, transistor Q606, and resistors R633, R630, and R636. Replace if necessary. Proceed to (6) below.

(6) Set AFC/MFC switch S601 at AFC. Using the oscilloscope, observe waveform at test point E621. If waveform (fig. 3-28) is observed, proceed to (8) below.

If waveform (fig. 3-28) is not observed proceed to (7) below.

(7) Check diode CR608, capacitor C610, and transistor Q607. Replace if necessary. Proceed to (8) below.

(8) Observe the waveform at J604 on the audio unit with the oscilloscope vertical input set to dc. If waveform A or B, figure 3-29 is observed, proceed to (9) below. If waveform A or B is not observed, proceed to step (10) below.

(9) Check that the baseline of the waveform can be moved between -70 and -145 volts by adjusting potentiometer R632. Proceed to (11) below.

(10) Check transistor Q606, resistor R634, and the connection to klystron V902. Replace if necessary. Proceed to (11) below.

(11) Set the POWER switch at TRANSMIT and AFC/MFC switch S601 to MFC. Observe waveform at jack J603 on the audio unit and adjust potentiometer R632 until a waveform appears. If waveform A, figure 3-27 is observed, proceed to (13) below. If waveform A, figure 3-27 is not observed, proceed to (12) below.

(12) Tune klystron local oscillator V902 (para. 3-41). Check diode CR603 and transistor Q607. Replace if necessary. Troubleshoot the afc unit (para. 5-23).

(13) Using the multimeter, measure the voltage between test points E621 and E601. If voltage is not between +3 and +20 volts, check transistor Q607 and replace if necessary.

(14) Set the POWER switch at OFF. Deenergize all test equipment and remove all cables. Replace the audio unit in the receiver-transmitter housing by performing procedures given in paragraph 3-64.

5-23. Afc Unit Troubleshooting

a. General. The afc unit contains all of the afc system with the exception of the afc search and control circuit which is contained in the audio unit. The afc unit is located in the lower portion of the receiver-transmitter center section (fig. 3-13).

b. Preparation.

(11) Remove the afc unit from the receiver-transmitter mounting plate (para. 3-65).

(2) Remove the five binding head screws and five lockwashers that secure the cover on the afc unit, and remove the cover (fig. 3-59).

(3) Connect plug P701 on the afc unit to jack J701 on the receiver-transmitter mounting plate (fig. 3-60) by means of the afc bench test cable.

c. Procedure.

(1) Set the POWER switch at TRANSMIT and AFC/MFC switch S601 on the audio unit at MFC.

(2) Remove the cover from the directional coupler J908 access hole (fig. 3-63) and remove the directional coupler cap. Place the pickup horn of the spectrum analyzer over the directional coupler J908 access hole, and observe the frequency spectrum displayed on the spectrum analyzer.

(3) Adjust potentiometer R632 on the audio unit until the klystron frequency is 30 MHz above the magnetron frequency as observed on the spectrum analyzer. Remove the spectrum analyzer and replace the directional coupler cap and access hole cover.

(4) Connect the oscilloscope between test point E714 and a ground on the afc unit. Observe the wave form on the oscilloscope. If waveform A, figure 4-15 appears proceed to (8) below. If no waveform A, figure 330 appears proceed to (5) below.

NOTE

Waveform A, figure 330 varies in amplitude and shape as the difference frequency is varied.

(5) Check the +24-volt output of the power converter system at test points E706 (+) and E712 and the -20-volt input at test point E731. If either voltage is not present, check continuity between afc unit and power converter system and troubleshoot the power converter system (para. 5-14). Proceed to (6) below.

(6) Using a multimeter, check the voltages on transistor Q702 (para. 3-4) and replace if necessary.

(7) Observe wave form at E712. If not similar to wave form B, figure 330, check the voltages on transistor Q701 and replace if necessary.

(8) Connect oscilloscope between test point E709 and ground. If waveform C, figure 3-30 appears, proceed to (9) below. If no waveform C, figure 3-30 appears perform the afc alignment (paras 3-40 and 3-41). Check diodes CR701, CR702, through CR704 and CR705 and replace if necessary.

(9) Connect the oscilloscope between test point E705 and ground. If waveform C, figure 3-0 appears proceed to (10) below. If no waveform C, figure 3-30 appears check Q703 and replace if necessary.

(10) Connect the oscilloscope between test point E703 and ground. If waveform D, figure 3-30 appears proceed to (11) below. If no waveform D, figure 3-30 appears, check Q704 and replace if necessary.

(11) Connect oscilloscope between jack J701 and the afc unit and ground. If waveform B, figure 3-27 does not appear, check transistor Q705 and replace if necessary.

(12) Set POWER switch S101 at OFF. Deenergize all test equipment and remove all cables and repair patch cord. Replace the afc unit in the receiver-transmitter housing by performing paragraph 3-65.

5-24. Range Unit Troubleshooting

a. When the output specified in the corrective measures column of paragraph 3-21 for jack J405 is not obtained, set POWER switch at TRANSMIT and check the output at jack J404 with the

oscilloscope. The output should be a waveform similar to the one illustrated in D, figure 3-35. If the output is correct, proceed to *b* below. If the output is not correct but is a waveform similar to that in A, figure 3-37, proceed to *e* below. If the output is a waveform similar to that in B, figure 3-37, proceed to *j* below.

b. Check E427 (fig. 3-36) with the oscilloscope for a signal similar to that indicated in E, figure 3-35. If there is a signal here, check Q407 and replace if necessary.

c. If there is no signal at E427, check E426 (fig. 3-36) with the oscilloscope for a signal similar to that indicated in E, figure 3-35. If there is a signal here, check Q406 and replace if necessary. Check E401 and E416. The waveform at E401 should be similar to that at jack J404 on the range unit but with a base line at -5 volts or more negative. The waveform at E416 should be similar to that at jack J404 but inverted and with a base line at +5 volts or more positive. If these waveforms are not correct, check diodes CR413- and CR414.

d. If there is no signal at E426, check continuity for shorts to ground and open circuits to E412. Check CR413 and CR414, and replace if necessary.

e. Check jack J402 on the range unit, with the multimeter. The output here should be a steady dc voltage of approximately -2.2 +0.2 volts. If the output is not correct, check the connections to the strobe unit.

f. If the voltage at J402 is correct, check J406 on the range unit, with the multimeter. If the voltage here is not between 20 and 30 volts, check the connections to the control panel; check for +60 (+3, -0) volts at E422 (fig. 3-36) on the range unit; if +60 volts is not present, check diodes CR405 and CR417 and replace if necessary.

g. If +60 volts is present at E422, check jack J1 on the range unit, with the oscilloscope. The output here should be a waveform similar to that in A, figure 3-35. If the waveform is not correct, check jack J408 with the oscilloscope.

(1) If the multiar pulse (fig. 3-38) is present at jack J408, troubleshoot the transmitting system.

(2) If there is no multiar pulse at jack J408, check E407 for the presence of a multiar pulse of approximately 15 volts in amplitude. If it is present, check transformer T401.

(3) If the multiar pulse is not present at E407, check for a sweep at E405 (fig. 336). If the sweep is present here, check diode CR411 and transistor Q404 and replace if necessary.

(4) If there is no sweep at E405, check for a sweep at E408. If the sweep is present here, check for open capacitor C406.

(5) If there is no sweep at E408, check E415 for the sweep (fig. 3-39); if it is present, check transistors Q402 and Q403 and replace if necessary.

(6) If there is no sweep at E415, check E433 for a square wave, 60 volts in amplitude (fig. 3-40). If it is present and the voltage at E415 is approximately at ground potential, check diodes -CR416 and CR407 and replace if necessary. If a square wave is present at E438 and the voltage at E415 is approximately +60 volts, check diode CR406 and replace if necessary.

(7) If there is no square wave at E433, check E431 for a square wave, about 1 volt in amplitude. If the square wave is present at E431, check diode CR403 and replace if necessary.

(8) If there is no square wave at E431, check diode CR402 and replace if necessary.

h. Check E425 for the blocking oscillator pulse. If it is not present, check transistor Q405 and replace if necessary.

i. If the output at E425 is correct, check transformer T402.

j. With the oscilloscope, check jack J403 on the range unit for the video input (C, fig. 3-35). If there is no video, check the connections to the IF amplifier unit; troubleshoot the signal IF amplifier.

k. With the oscilloscope, check jack J404 on the range unit for video. If there is no video at jack J404, check the continuity to jack J404 from E424, check capacitor C417 and replace if necessary.

5-25. Corrective Measures for Troubleshooting the Strobe Circuit

To troubleshoot the strobe circuit, proceed as follows:

a. Set the POWER switch at TRANSMIT and the STROBE switch at OFF.

b. With the oscilloscope, measure the voltage at jack J402 on the range unit. The voltage here should be 2.2 +0.111 volts. If it is not 2.2 +0.11 volts, proceed as follows:

(1) Check the voltage at the junction of resistor R1013 and diode CR1003. If the voltage here is 2.2 volts, check the connections between the strobe unit, the strobe switch, and the range unit.

(2) If the voltage at the junction of resistor R1013 and diode CR'1003 is not 2.2 volts, check diode CR1003 and replace if necessary.

c. Set the STROBE switch at LONG. The needle on RANGE EXTENSION METERS meter M101 should strobe from 0 to 500 meters. If there is no strobing action on meter M101, proceed as follows:

(1) Check for a sweep at the junction of resistors R1009 and R1018 with the multimeter. If the sweep is present here, check the connections to the STROBE switch and the range unit; check continuity to meter Mi101 from the junction of resistors R1014 and R1015.

(2) If the sweep is not present at the junction of resistors R1009 and R1018, check for the sweep at the junction of resistor R1012 and potentiometer R1017. If the sweep is present here, check continuity from resistors R1012 to R1018.

(3) If the sweep is not present at the junction of resistor R1012 and potentiometer R1017, check for the sweep at the base of emitter follower Q1001. If the sweep is present here, check Q1001 and Q1002 with the transistor tester and replace if necessary.

(4) If there is no sweep at the base of emitter follower Q1001, check continuity from -150 volts to resistor R1002 and thermister RT1002 to resistor R1004 and to resistor R1003. Check Zener diode CR1001; check four-layer diode CR1002 (para. 3-10).

5-26. Audio Amplifier Circuit Troubleshooting

If the noise level at pin 5 of audio transformer T1 (fig. 3-1) is incorrect, (paras 3-22 and 5-12) proceed as follows:

a. Connect the Generator Signal AN/URM-127 output to pin N of plug P601 and set the output for 0.2 volts peak-to-peak at 300 Hz.

b. Connect Oscilloscope AN/USM-281 between test point E624 and ground. Use the AN/ URM-127 output to synchronize the AN/USM- 281.

c. Set the POWER switch at STANDBY and the STROBE switch at OFF and observe the AN/USM-281 for a sine wave (waveform B, fig. 3-41). If not present, continue with the procedures below.

d. If sinewave is not present, check transistor Q601; replace if defective.

e. If sinewave is observed but is not limited at the positive peak, replace crystal CR601. If the sinewave is not limited at the negative peak, replace crystal CR606.

f. Connect the oscilloscope between test point E606 and proceed. Observe waveform C, figure 3-41. If not present, check transistor Q609; replace if defective.

g. Connect the oscilloscope to pin 5 of audio transformer T1 and ground. Observe waveform E, figure 3-41. If the positive half cycle is abnormal, check transistor Q602; replace if defective. If the negative half cycle is abnormal, check transistor Q603; replace if defective.

Section III. REPAIR, REMOVAL, AND REPLACEMENT

5-27. General

Repair, removal, and replacement at the general support maintenance level includes repair and replacement of all components necessary to re- turn a defective radar set to operation. Spare parts normally stocked at the general support level are listed in the repair parts and special tools list (RPSTL) in appendix B.

5-28. Removal of Potentiometer R103

a. Place the POWER switch on the control panel in the OFF position.

CAUTION

Care should be taken in handling the control panel to prevent damage to meter M101, the strobe unit, and the exposed wiring.

b. Release the four trunk-type latches that secure the control panel to the rear of the receiver-transmitter, and remove the control panel (fig. 3-8).

c. Remove the strobe unit by removing four binding head screws and disconnecting jack J105 from plug P105 of the strobe unit by loosening two knurled captive screws.

d. Identify, mark, and unsolder the three connecting leads of potentiometer R103 (fig. 3-31).

e. Remove the RANGE CONTROL handwheel (1) on the front of the control panel (fig. 343) by loosening the two setscrews (2) contained in the neck of the handwheel. Remove the hex nut seal (3).

NOTE

On first inspection of the handwheel, the two setscrews might not be accessible. Turn the handwheel against the

limit stop until both setscrews are accessible through the outer holes of the handwheel.

f. In order to gain access to potentiometer R103 (11), remove the five binding head screws (4, 5, 6), three hex nuts (8), and three lock-washers (7) that fasten the gearbox (10) of the dial assembly to the control panel and remove the dial assembly.

g. Loosen the three servo clamps (9) that secure potentiometer R103 to the dial assembly gearbox (10).

CAUTION

Care must be taken to prevent damage to the gears and to prevent separation of the spring-loaded anti-backlash gear, and also loss of the washers.

h. To insure that the gear halves of the anti-backlash gear (12) remain together, carefully bind them with soft wire or tape.

CAUTION

In removing the taper pin, make certain that the pin is removed from the side of the gear hub with the larger opening.

i. Drive out the taper pin (13) that secures the anti-backlash gear (12) on the potentiometer shaft.

j. Carefully remove the potentiometer (11) from the dial assembly gearbox (10).

k. Remove the anti-backlash gear (12) from the dial assembly gearbox.

5-29. Replacement of Potentiometer R103

a. Assemble the anti-backlash gear (12) to the shaft of the new 50K potentiometer R103 (11) as shown in figure 3-43.

b. Insert one No. 6-32 x 1/4 screw in the threaded hole of the anti-backlash gear.

c. The distance between the mounting surface of potentiometer R103 and the mating surfaces of the anti-backlash gear halves must be 1.250 inches. Mark on the shaft of the potentiometer the position of the taper pin that will permit this 1.250-inch distance, and tighten the No. 6-32 x 1/4 screw to secure the gear to the potentiometer shaft.

d. Using the taper pin hole in the anti-backlash gear as a guide, drill through the potentiometer shaft with a No. 62 drill. Taper ream the hole for a No. 8/0 taper pin.

e. Remove the No. 6-32 screw from the hub of the anti-backlash gear and remove the anti-backlash gear from the potentiometer shaft.

f. Rotate the potentiometer shaft in a counterclockwise direction, as viewed from the driving end, until it reaches an internal stop.

g. Temporarily install the RANGE CONTROL handwheel (11) on the handwheel shaft (14) and fasten in place with the two setscrews (2) in the neck of the handwheel.

h. Rotate the handwheel until the counter of the RANGE METERS indicator (16) reaches the zero position.

i. Hold the anti-backlash gear (12) in its correct position in the dial assembly. Slide the potentiometer (11) shaft through the hub of the anti-backlash gear (12) and install it carefully into position without moving the gear (18) connected to the RANGE CONTROL handwheel shaft (14), or without rotating the potentiometer (11) from its extreme counterclockwise position. Make sure that the potentiometer terminal lugs are positioned correctly so that they will not make contact with the control panel when the dial assembly is installed in the control panel.

NOTE

If the tension of the spring-loaded, anti-backlash gear is accidentally lost, one gear half must be offset by one or two teeth from the other in either direction until the spring tension is restored. Make sure that the potentiometer (11) shaft remains in its extreme counterclockwise position.

j. Insert and secure one No. 8/0 taper pin (13) in the previously drilled hole to lock the anti-backlash gear (12) to the potentiometer (11) shaft.

k. Fasten the three servo clamps (9) that secure the potentiometer (11) to the dial assembly gearbox (10).

l. Check the RANGE METERS indicator (16); in the extreme counterclockwise position, the counter must indicate zero. If the counter does not indicate zero, perform the adjustment in paragraph 3-27 immediately.

m. After the RANGE METERS indicator (16) adjustment has been checked and the potentiometer (11) has been secured in place, carefully (remove the soft wire or tape used to prevent separation of the anti-backlash gear (12) during the potentiometer (11) replacement. Loosen the two setscrews (2) in the neck of the RANGE CONTROL handwheel (1) and remove the handwheel.

n. Install and align the dial assembly on the rear of the control panel (fig. 3-1) and se-

cure the dial assembly in place with two No. 8-32 x 5/8 binding head screws (4) (fig. 3-43), two No. 8-32 x 2 1/4 binding head screws (6), one No. 8-32 x 1/2 binding head screw (5), three No. 8 lockwashers (9), and three No. 8-32 hex nuts (8).

NOTE

Make sure that the potentiometer terminal lugs do not make contact with the control panel.

o. Install the hex nut seal (3) and the RANGE CONTROL handwheel (1). Secure the hand-wheel in place with the two setscrews (2).

p. Connect and solder the three previously marked leads to potentiometer R103 (11).

q. Install the strobe unit (fig. 3-8) on the control panel and secure in place with four no. 6-32 x 5/8 binding head screws. Connect plug P105 to jack J105 (fig. 3-31) and tighten the two knurled captive screws.

r. Install the control panel on the rear of the receiver-transmitter and secure in place with four trunk-type latches.

NOTE

Make sure that jack J101 (fig. 3-9) is in firm contact with plug P101' (fig. 3- 81) of the control panel.

5-30. Transmitting System

The transmitting system consists of components enclosed in the transmitter unit, magnetron V901 which is mounted on the waveguide assembly, and the cable interconnecting the transmitter unit and magnetron V901.

WARNING

High voltages exist in the transmitting system at the modulator, the pulse unit, and the magnetron.

NOTE

Most replacement of parts can be done with the transmitter unit in place in the receiver-transmitter.

a. Removal of Transmitter Unit. To remove the transmitter unit perform the procedures in paragraph 3-61.

b. Replacement of Transmitter Unit. To replace the transmitter unit perform the procedures in paragraph 3-61.

c. Removal of Circuit Board. To remove the circuit board from the transmitter unit chassis, the transmitter unit plate must be removed.

(1) Remove the transmitter unit as directed in paragraph 3-61.

(2) Remove the four binding head screws, four lockwashers, and four plain washers that fasten the cover on the transmitter unit. Remove the cover.

(3) Unscrew the four extension studs and lockwashers from the transmitter unit plate.

(4) Remove the binding head screw and lockwashers which are located next to pulse unit Z201 (fig. 3-14).

(5) Remove the two microdot connectors from jacks J206 and J207 on either side of the transmitter unit chassis.

(6) Lift out the transmitter unit plate.

(7) Remove the two screws which fasten the circuit board to the bottom of the transmitter unit plate.

(8) Lift up the circuit board and unsolder and tag the seven wires from the bottom of the circuit board.

d. Replacement of Circuit Board. Replace the circuit board in the transmitter unit chassis as follows:

(1) Solder the seven tagged wires on the transmitter unit plate to the bottom of the circuit board.

(2) Place the circuit board on the transmitter unit plate and replace the two 6-32 x 1/2 binding head screws which fasten the circuit board to the plate.

(3) Replace the transmitter unit plate in the transmitter unit chassis.

(4) Reconnect the two microdot connectors to jacks J206 and J207 (fig. 3-14) on the sides of the transmitter unit chassis.

(5) Replace the No. 632 x 5/16 binding head screw and No. 6 lockwasher next to pulse unit Z201.

(6) Replace the four extension studs and four No. 6 lockwashers on the transmitter unit plate.

(7) Replace the transmitter unit cover and secure the cover in place with four No. 6-32 x 5/16 binding head screws, four No. 6 lockwashers and four No. 6 plain washers.

(8) Replace the transmitter unit as directed in paragraph 3-61.

5-31. Automatic Frequency Control System

The afc system consists of all the components in the afc unit and the afc search and control circuit of the audio unit.

a. Removal of Afc Unit.

WARNING

Before following the procedure described below, place the POWER switch in the OFF position.

CAUTION

Care should be taken in handling the control panel to prevent damage to meter strobe unit, and exposed wiring.

(1) Release the four trunk-type latches (fig 3-13) that secure the control panel to the receiver-transmitter housing, remove the control panel, and place it in the support fixture.

(2) Remove the afc unit following procedures given in paragraph 365.

(3) If individual components on the afc circuit board (figs. 3-21 and 3-22) are to be removed and replaced, proceed as follows:

(a) Remove the five binding head screws and five lockwashers that secure the cover on the afc unit, and remove the cover (fig. 3-59).

CAUTION

When performing the following disassembly procedures, use extreme care to prevent stress on the interconnecting wiring and fragile circuit board.

(b) Loosen the clamping nut that fastens jack J703 (fig. 3-22) to the chassis of the afc unit, and slide jack J703 with its attached cable from the slotted opening in the chassis.

(c) Loosen the clamping nut that fastens jack J702 to the afc unit chassis, and slide jack J702 from the slotted opening in the chassis.

(d) Unscrew and remove the five stand-off posts and five plain washers from the afc circuit board (fig. 3-21.).

(e) Remove the two binding head screws and two plain washers that fasten plug P701 to the afc unit chassis, and lift out the afc circuit board (fig. 3-22).

b. Replacement of Afc Unit.

(1) Replace the afc circuit board in the afc unit chassis.

(2) Replace the two No. 4-40 x 5/16 binding head screws and two No. 4 plain washers that fasten plug P701 to the afc unit chassis.

(3) Replace the five standoff posts and associated No. 6 plain washers that secure the afc circuit board to the afc unit chassis.

(4) Slide the threaded portion of jack J702 into the slotted opening in the afc unit chassis and tighten the clamping nut that secures jack J702 in place.

(5) Slide the threaded portion of jack J703 into the slotted opening in the afc unit chassis and tighten the clamping nut that secures jack J703 in place.

(6) Assemble the cover to the afc unit and secure the cover (fig. 3-59) in place with five No. 4-40 x 5/16 binding head screws and five No 4 lockwashers.

(7) Replace the afc unit and control panel following procedure given in paragraph 3-65.

c. Removal of Audio Unit.

(1) Release the four trunk-type latches (fig. 3-13) that secure the control panel to the receiver-transmitter housing, remove the control panel, and place it in the support fixture.

CAUTION

Care should be taken in handling the control panel to prevent damage to meter M101, the strobe unit, and exposed wiring.

(2) Remove audio unit following procedures given in paragraph 3-64.

(3) If individual components on the audio circuit board (figs. 3-23 and 3-24) are to be removed and replaced, proceed as follows:

(a) Remove the five binding head screws and five lockwashers that fasten the cover on the audio unit, and remove the cover (fig. 3-5).

(b) Unscrew and remove the five stand-off posts and five plain washers from the audio circuit board (fig. 3-23).

(c) Remove the two binding head screws and two plain washers that fasten plug P601 to the audio unit chassis.

(d) Unscrew and remove the clamping nut and plain washer that fasten AFC/MFC switch S601 to the audio unit chassis and lift out the audio circuit board.

d. Replacement of Audio Unit.

(1) Replace the audio circuit board in the audio unit chassis.

(2) Replace the clamping nut and plain washer that secure AFC/MFC switch S601 to the audio unit.

(3) Replace the five standoff posts and associated No. 6 plain washers that secure the audio circuit board to the audio unit chassis.

(4) Replace the two No. 4-40 x 5/16 binding head screws and two No. 4 plain washers that fasten plug P601 to the audio unit chassis.

(5) Assemble the cover on the audio unit and secure the cover (fig. 368) in place with five No. 4-40 x 5/16 binding head screws and five No. 4 lockwashers.

(6) Complete the replacement procedures as outlined in paragraph 3-4.

5-32. Ranging System

The components of the ranging system are located in the strobe and range units. When aligning and testing the ranging system, it is usually not necessary to remove the range and strobe units. However, to replace parts in the range and strobe units or to trouble shoot the range unit, these units must be removed from the receiver-transmitter. To remove the range unit, follow the procedure given in paragraph 3-62. To replace the range unit, follow the procedure given in paragraph 3-62. To remove the strobe unit, follow the procedure given in paragraph 3-60. To replace the strobe unit follow the procedure given in paragraph 3-60. To remove the printed circuit board from the range unit, follow the procedure given in c below. To replace the board, follow the procedure given in paragraph d below.

a. Removal of the Range Unit. To remove the range unit from the mounting plate in the center section of the receiver-transmitter (fig. 3-9), proceed as follows:

(1) Set the POWER switch at OFF and remove the power cable from 24VDC BAT. ONLY receptacle J104.

CAUTION

Care should be taken in handling the control panel to prevent damage to meter M101, the strobe unit, and exposed wiring.

(2) Release the four trunk-type latches that fasten the control panel on the rear of the receiver transmitter and remove the control panel.

(3) Remove the range unit from the mounting plate by performing the procedures given in paragraph 3-62.

b. Replacement of Range Unit. To replace the range unit on the mounting plate in the center section of the receiver-transmitter (fig. 3-9), follow the procedure given in, paragraph 3-62.

c. Removal of Printed Circuit Board. To remove the printed circuit board from the range unit chassis, follow the procedure given below.

(1) Remove the five binding head screws that fasten the cover on the range unit (fig. 3-55).

(2) Slide off the cover.

(3) Use a wrench to remove the five stud extensions from the range unit.

(4) Remove the two screws that fasten,

plug P401 on the range unit chassis.

(5) Remove jack J408 from the range unit chassis.

(6) Remove the two clamps which hold the cable terminating in jack J408 to the circuit board.

(7) Unscrew jack J407 and the ground lug from the side of the range unit (fig. 3-38).

(8) Remove the circuit board from the range unit.

d. Replacement of Printed Circuit Board. To replace the printed circuit board in the range unit, follow the procedure given below.

(1) Place the circuit board in the range unit.

(2) Screw jack J407 and the ground lug to the side of the range unit (figs 332 and -33).

(3) Replace the two clamps which secure the cable terminating in jack J408 in place.

(4) Replace jack J408 on the range unit.

(5) Attach plug P401 to the range unit by means of two No. 4-40 x 1/4 binding head screws and two No. 4-40 lockwashers.

(6) Screw five 3/4-inch long stud extensions into the range unit.

(7) Slide the cover onto the range unit.

(8) Secure the cover in place with five No. 4-40 x 8/8 binding head screws and five No. 4 lockwashers.

5-33. Audio System

Audio transformer T1 and audio filter FLS are located on the front side of the center section of the receiver-transmitter (fig. 3-1). RF filters FL103 and FL104 are located on the control panel of the receiver-transmitter (fig. 3-8). The remaining components of the audio system are located on the audio unit which is located on the rear side of the receive 'r-transmitter center section (fig. 3-16). The filters and the audio transformer can be removed by tagging and unsoldering the connecting leads. Transistors are removed and replaced according to the procedure given in paragraph 5-6. To remove the audio and the circuit board from the audio unit, follow the procedure given in paragraph 5-1. To replace the audio unit and the circuit board in the audio unit, follow the procedure given in paragraph 651. If it is necessary to replace the audio unit, the following adjustments must be performed: receiver threshold adjustment (para. 3-61); and afc sweep adjustment R632 (para. 3-41).

5-34. Automatic Gain Control System

The components of the agc system are located in the audio unit (figs. 3-23, and -24). When troubleshooting, aligning, or testing the age system, the audio unit is not usually removed. However, to replace parts, it is necessary to remove the audio unit. To do so, follow the procedure given in paragraph 3-64. To remove and replace, the printed circuit board of the audio unit, follow the procedures in paragraph 5-31. To replace transistors Q604 and Q605, follow the procedure given in paragraph 5-6.

5-35. Power Converter System

The power converter system consists of the components enclosed in the power converter unit, capacitor C6, and reactor L1 which are mounted on the microwave assembly in the receiver-transmitter center section.

WARNING

Extremely high voltages exist in the power converter system at the + 270-volt line.

NOTE

Most troubleshooting and replacement of parts can be accomplished with the power converter unit in place.

a. To remove the power converter unit, follow the procedures given in paragraph 3-63.

b. To make transistors Q801 and Q802 (fig. 3-611) and diodes CR803, CR804, CR809, CR810, CR812, and CR813 (fig. 3-42) more accessible, loosen the heat dissipation plate to which they are attached by removing the seven No. 6-32 by 3/8 binding head screws and seven No. 6 lockwashers that secure the plate in place.

CAUTION

When loosening the heat dissipation, plate, do not apply any undue stress upon the transistor and diode interconnecting leads.

c. To make capacitor C6 and reactor L1 more accessible, remove the two hex nuts and two washers which secure the plate on which C6 and L1 are mounted to the microwave assembly, and also remove the hex nut and washer which secure capacitor C6 to the center section mounting plate.

d. Assemble the heat dissipation plate, with transistors and diodes attached, to the power converter unit and secure the plate in place with

seven No. 6-32 by 3/8 binding head screws and seven No. 6 lockwashers.

e. To replace the power converter unit, follow the procedures given in paragraph 3-66.

f. To replace capacitor C6 and reactor L1 in the center section proceed as follows:

(1) Install the plate on which capacitor C6 and reactor L1 are mounted on the microwave assembly, and secure the plate in place with two No. 10 lockwashers and two No. 10-32 hex nuts.

(2) Secure the clamps on capacitor C6 to the center section mounting plate by replacing one No. 110 lockwasher and one No. 10-32 hex nut.

(3) Install the radome on the receiver-transmitter and secure the radome in place by fastening the four trunk-type latches.

g. Transistors Q80 and Q802 are removed by unsoldering the transistor leads using a heat sink on the transistor lead between the solder connection and the transistor, unscrewing the nut which holds the transistor to the heat dissipation plate, and removing the mica insulator and transistor.

h. To replace transistors Q801 and Q802 follow the procedures below.

(1) Liberally apply silicone grease (MIL-I-8660) to both sides of the insulator, to the heat dissipation plate side of the mica washer, and to the transistor base.

(2) Install the insulator and two insulating bushings to the transistor and install the transistor to the heat dissipation plate.

(3) Secure the transistor in place with a mica washer, flat washer, solder terminal, and hex nut.

(4) Tighten the hex nut to a pressure of 12 ounce-inches.

NOTE

The silicone grease should be forced from the base of the transistor and insulator when the hex nut is tightened.

(5) Solder transistor Q801 with a heat sink on the transistor lead between the solder connection and the transistor. The transistor should be placed so that the base is connected to tap 6 of transformer T802, the emitter is connected to ground, and the collector is connected to pin 33 of plug P801.

(6) Solder transistor Q802 with a heat sink on the transistor lead between the solder connection and the transistor. The transistor should be placed so that the base is connected to tap 3 or

transformer T803, the emitter is connected to ground, and the collector is connected to pin 34 of plug P801.

5-36. Receiving System

The receiving system consists of components in the IF amplifier unit, klystron V902, and the signal mixer crystals. For removal and replacement procedures for klystron V902 and the signal mixer crystals, refer to paragraph 3-67.

a. Removal of the IF Amplifier Unit Circuit Board.

WARNING

Before following the procedure below, place the POWER switch in the OFF position.

(1) Remove the IF amplifier unit from the center section of the receiver-transmitter as described in paragraph 3-3.

(2) Remove the nine binding head screws and nine lockwashers that fasten the cover on the IF amplifier unit and remove the cover (fig. 3-56).

(3) Remove the four corner studs, four lockwashers, and four flat washers from the circuit board.

(4) Remove the four binding head screws and four lockwashers that fasten the mounting plate for jack J501 to the IF amplifier unit.

(5) With an offset screwdriver, remove the two screws which fasten the mounting plate for cables terminating in plugs P50g, P504 and P505 to the IF amplifier unit.

(6) Unsolder the lead from terminal point 10 at jack J502 (fig. 3-15).

(7) Unsolder the three leads from the blanking pulse sub-chassis at their terminal points on the circuit board.

(8) Remove the four binding head screws, lockwashers, and flat washers that fasten the circuit board to the IF amplifier unit chassis and remove the circuit board.

b. Replacement of Circuit Board.

(1) Install the IF amplifier unit circuit board in the IF amplifier unit chassis and fasten the circuit board in place with four No. 4-40 x 5/16 binding head screws and four No. 4 lockwashers.

CAUTION

Be sure to guide the three leads from the blanking pulse sub-chassis through the notches in the circuit board.

(2) Solder the three leads from the blanking pulse sub-chassis to the circuit board.

NOTE

These leads and their terminal points on the circuit board are color coded. Be sure to match the color of the wire to the color of its terminal point.

(3) Solder the lead from terminal point 10 (fig. 3-15) on the circuit board to jack J502.

(4) Install the two No. 4-40 x 5/16 binding head screws that fasten the mounting plate for cables which terminate in plugs P503, P504, and P605, to the IF amplifier unit.

(5) Install the four No. 4-40 x 5/16 binding head screws and four No. 4 lockwashers that fasten the mounting plate for plug P501 to the IF amplifier unit.

(o) Install four corner studs, four No. 6 lockwashers, and four No. 6 flat washers on the circuit board.

(7) Install the cover on the IF amplifier unit and fasten the cover in place with nine No. 4-40 x 5/16 binding head screws and nine No. 4 lockwashers (fig. 3-56).

(8) Check the alignment of the IF amplifier unit by following the alignment procedures given in paragraph -37.

(9) Replace the IF amplifier unit on the center section of the receiver-transmitter as described in paragraph 3-63.

c. Removal of Blanking Pulse Sub-chassis.

WARNING

Before following the procedure below, place the POWER switch in the OFF position.

(1) Remove the IF amplifier unit circuit board as described in a above.

(2) Remove the two binding head screws that fasten the blanking pulse sub-chassis to the IF amplifier unit chassis, and remove the sub-chassis (fig. 3-67).

(3) Disconnect IF blanking pulse cable clamp by removing one binding head screw, one lockwasher, and one plain washer.

d. Replacement of Blanking Pulse Sub-chassis.

(1) Guide the three leads from the blanking pulse sub-chassis through the notches in the IF amplifier unit circuit board (fig. 3-15).

(2) Install the blanking pulse sub-chassis on the IF amplifier unit and fasten in place with two No. 4-40 x 5/16 binding head screws.

(8) Connect the IF blanking pulse cable clamp to the IF amplifier unit with one No. 44

x 1/2 binding head screw, one No. 4 lockwasher, and one No. 4 plain washer.

e. Removal of Filters for Jacks J506 and J507 (fig. 3-16).

NOTE

Filters for jacks J506 and J507 are identified as crystal current filter network on figure 7-7.

- (1) Remove the IF amplifier unit circuit board as described in paragraph *a* above.
- (2) Remove the two screws and two locknuts which hold the case of the filter to the circuit board.
- (3) When removing the filter for jack J506 tag and unsolder the wire leading to terminal

point 75 on the filter. When removing the filter for jack J507, tag and unsolder the wire leading to terminal point 72 on the filter.

f. Replacement of Filter for Jacks J506 and J507.

- (1) Replace the two No. 4--40 x 3/4 screws and two No. 4-40 locknuts which hold the case of the filter to the circuit board.
- (2) When replacing the filter for jack J506, solder the lead from the circuit board to terminal point 75 on the filter. When replacing the filter for jack J507, solder the lead from the circuit board to terminal point 72 on the filter.
- (3) Replace the IF amplifier unit circuit board as described in *b* above.

Section IV. DISASSEMBLY AND REASSEMBLY OF TRIPOD

5-37. Tripod Assemblies

The tripod consists of two major assemblies: the tripod leg assembly (fig. 5-1 and the tripod head assembly (fig. 5-2). Use the procedures in paragraphs 5-38 through 5-42 to disassemble and reassemble the tripod assemblies.

5-38. Separating and Joining of Tripod Assemblies

a. General. *a* and *b* below cover separating and joining the tripod assemblies, and paragraphs 5-39 through 5-42 cover the disassembly and reassembly of the dismantled tripod assemblies.

b. Separating. To separate the tripod head assembly from the tripod leg assembly, proceed as follows:

- (1) Remove the special self-locking screw (1, fig. 5-1) which secures the fluted handle (2) to the tripod and remove the fluted handle (2), the washer (3) and retainer (4) from the tripod.

(2) Lift the tripod head assembly up and away from the tripod leg assembly.

c. Joining. To join the separated tripod leg assembly and tripod head assembly, proceed as follows:

- (1) Install the tripod head assembly on top of the tripod leg assembly.
- (2) Install the retainer (4, fig. 5-1) on the shaft at the bottom of the tripod head assembly and secure it by replacing the 7/8-inch diameter washer (3) and fluted handle (2).

(3) Secure the fluted handle (2) by replacing the special self-locking screw (1).

NOTE

Check to see that the insertion of the special self-locking screw (1) does not

impede free rotation of the fluted handle

(2) but provides a stop against unscrewing the handle completely.

(4) If the tripod head assembly rotates too loosely or too tightly in azimuth after the fluted handle (2) is tightened fully by hand, the following adjustment must be performed. Perform procedure in paragraph 5-39*n* through *p*. Loosen the socket head screw (34, fig. 5-2) and back off or tighten the collet (30) until proper rotation of the tripod head assembly is obtained. Perform procedures in paragraph 5-41*f*.

d. Tripod Test Specifications. The following conditions should be met to assure proper operation of the tripod after disassembly and reassembly procedures have been performed. If any of these conditions are not satisfied, the tripod components in question should be adjusted according to the reassembly procedures, paragraphs 41 and 42, until proper operation is obtained.

(1') The tripod should permit the receiver-transmitter unit to be firmly attached by means of mating wedges and secured in place by means of a captivated screw.

(2) The elevation mechanism should permit smooth motion of the receiver-transmitter unit over a vertical angle of 1, 150 mils (from -800 to +350).

(a) The angle of elevation should be indicated by a pointer and scale.

(b) The pointer should be on the same radius as the scale to prevent shadowing during reading.

(c) The pointer and adjacent scale should be illuminated by a light, which by hand adjustment, can be directed on either the elevation scale or the leveling bubble.

(d) The elevation lock handle should be capable of locking the angular elevation movement of the receiver-transmitter unit or, when unlocked, should be capable of permitting the free, smooth motion of the elevation angle over the specified angle of 1, 150 mils. The elevation lock handle should be spring loaded to the spline screw so that it may be disengaged from the spline screw, and moved to any position not restricted by the support casting. When locked by the elevation lock handle, the tripod head assembly should be restricted to zero degree of play. When unlocked, the maximum amount of free play of the tripod head assembly should be +1 degree. The return to an approximate zero position should be assisted by spring action with sufficient force to balance the eccentric loads of the receiver-transmitter unit through the specified elevation angle. The three adjustable detents should indicate, by feel in the control handle, preset elevation angles.

(3) The azimuth mechanism should permit a smooth continuous motion (6, 400 mils) of the receiver-transmitter unit in azimuth.

(a) During setup of the equipment, it should be possible to set the azimuth dial to any desired orientation independent of the position of the tripod by unlocking the four azimuth detents and rotating the dial with the fingertips.

(b) The azimuth angle should be indicated by an index mark.

(c) The index and scale should be illuminated by a fixed position light.

(d) The azimuth lock handle should lock the azimuth rotation of the receiver-transmitter unit, or when unlocked, should permit a free smooth rotation in azimuth. Complete locking of the azimuth lock handle should occur between 50 percent and 75 percent of level motion.

(e) Four adjustable azimuth detents should indicate (by feel in the control handle) preset azimuth angles.

(4) The fluted handle level lock mechanism should permit smooth motion of the receiver-transmitter unit and tripod head assembly in a hemispherical angle.

(a) The level plane should be indicated by a leveling bubble located on the support casting, and adjacent to the elevation dial.

(b) When locked by the fluted level lock handle, there should be no motion in any direction when a force of approximately 85 pounds is applied at the control handle.

(c) When locked by a normal locking force, the end play on the center shaft should not exceed 0.003 inch.

(d) Once the level position is obtained, there should be a maximum of a half-bubble wide displacement of the leveling bubble as the handle goes from a released to a locked position.

(5) The tripod leg assembly should support the receiver-transmitter unit and tripod head assembly and permit them to be positioned so that the lower edge of the receiver-transmitter unit housing may be located at any point between 1 and 5 feet above ground level.

(a) The serrated tooth leg locking assemblies should permit each individual leg a full 90-degree swing from stop to stop. In the stowed position, the leg tip flanges should be within 3/4 inch of touching each other.

(b) The leg should be released for adjustment by turning the wingnut to the maximum open position and pressing the release button. This action should be free from sticking.

(c) When the leg is at either position limited by the stops, the serrated castings should mesh by tightening of the wingnut, without requiring adjustment of the leg.

(d) The leg extension lock knob assembly should lock the inner leg to the outer leg at any height allowed by the configuration of parts. When locked, the legs should not collapse due to static loads of 190 pounds applied vertically downward on the receiver-transmitter mounting surface.

5-39. Disassembly of Tripod Head Assembly

The directions in *a* through *ay* below cover the disassembly of the tripod head assembly after it has been separated from the tripod leg assembly (para. 5-38*b*).

a. Unscrew the control handle assembly (consisting of spring pin (1), shoulder pin (2), bushing (3), handle tube (4) and flex grip (5)) from the tripod head casting (55, fig. 6-2).

b. Remove the spring pin (1) which holds the components of the control handle together.

c. Separate the shoulder pin (2), bushing (3), and handle tube (4) from the flex grip (5) of the control handle.

d. Insert a wrench through the rectangular opening in the scale support (41) at the bottom of the tripod head assembly and unscrew the hexagonal nut (6) which secures the azimuth lock handle (11) to the support casting (54).

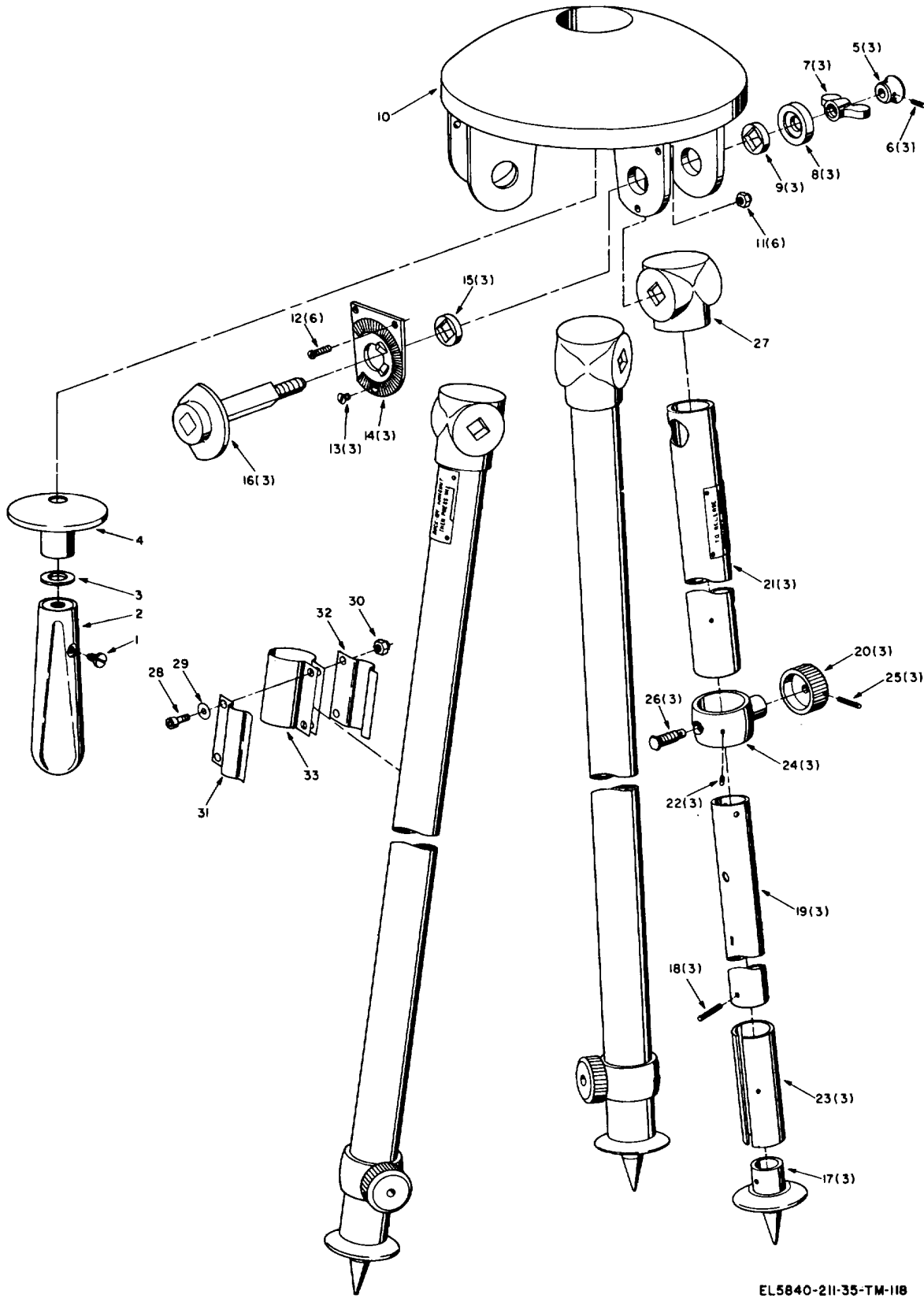

EL5840-211-35-TM-118

Figure 5-1. Tripod leg assembly, exploded view.

1	Screw, special self-locking	18	Spring pin 0.125 x 1 (3)
2	Handle, fluted	19	Inner leg (3)
3	Washer 7/8 in. dia.	20	Knob (3)
4	Retainer	21	Outer leg (3)
5	Cap (3)	22	Spring pin 0.094 x 1 5/16 (3)
6	Spring pin 0.078 x 5/8 (3)	23	Loop clamp (3)
7	Wingnut (3)	24	Locking clamp (3)
8	Washer (3)	25	Spring pin 0.078 x 15/16 (3)
9	Bearing sleeve (3)	26	Stud (3)
10	Support	27	Leg adapter (3)
11	Hex nut 10-32 (6)	28	Socket-head capscrew 8-32 x 3/4 (2)
12	Special screw 10-32 x 3/4 (6)	29	Plain washer No. 8 (2)
13	Flat head screw 8-32 x 1/4 (3)	30	Hex-nut 8-32 (2)
14	Serrated clamp (3)	31	Clip half
15	Bearing sleeve (3)	32	Clip half
16	Bolt (3)	33	Clamp
17	Tripod leg tip (3)		

Figure 5-1—Continued.

e. Unscrew the stud (7) from the azimuth lock handle (11) and remove the stud (7), clamp (8), and spring (9) through the rectangular opening in the scale support (41) at the bottom of the tripod head assembly.

f. Remove the azimuth lock handle (11) and washer (10) from the support casting.

g. Unscrew the binding head screw (12) which secures the elevation lock handle (17) to the tripod head assembly, and remove the binding head screw (12), locking ring (13), retaining washer (14), spring (15), ring washer (16), and elevation lock handle (17) from the tripod head assembly.

h. Unscrew the spline screw (18) from the tripod head assembly and remove the spline screw (18) and the outer dog washer (19).

NOTE

Perform *i* and *j* below only if the sliding guides (20, 23) or the spacers (22) have to be replaced; otherwise, proceed to *k* below.

i. Use a 3/32-inch diameter drill bit to drill out the two rivets (24) which secure the sliding guides (20 and 23) to the tripod head assembly.

NOTE

When drilling out rivets, use extreme care to keep the drill centered at all times.

j. Remove the outer sliding guide (20), inner dog washer (21), two spacers (22), and inner sliding guide (23) from the tripod head assembly.

k. Drive out the spring pin (25) which secures the knob (26) of the pin (29) to the tripod head assembly.

l. Slide the knob (26) and washer (27) off the pin (29).

m. Withdraw the pin (29) and washer (28) through the wedge-shaped opening in the tripod head casting (55).

n. Remove the two binding head screws (30) and two plain washers (31) which secure the identification plate (32) to the tripod head assembly.

o. Rotate the tripod head casting (55) in elevation until the identification plate (32) becomes accessible through the wedge-shaped opening in the tripod head casting (55).

p. Unhook the identification plate (32) from the cover plate (33) and remove the identification plate through the wedge-shaped opening in the tripod head casting (55).

q. Remove the two binding head screws (30) and two plain washers (31) which secure the cover plate (33) to the tripod head assembly.

r. Rotate the tripod head casting (55) in elevation until the cover plate (33) becomes accessible through the wedge-shaped opening in the tripod head casting (55), and remove the cover plate.

s. Use a 3/32-inch Allen wrench to loosen the socket head capscrew (34) which secures the collet (35) to the shaft (37), unscrew the collet (35), and remove the collet (35) and the flat washer (36) from the shaft (37).

t. Lift the upper portion of the tripod head assembly away from the lower portion.

u. Remove the six flathead screws (38) which secure the connecting ring (39) to the scale support (41) in the lower portion of the tripod head assembly, and remove the connecting ring (39).

v. Slip the azimuth scale dial (40) from around the scale support (41)

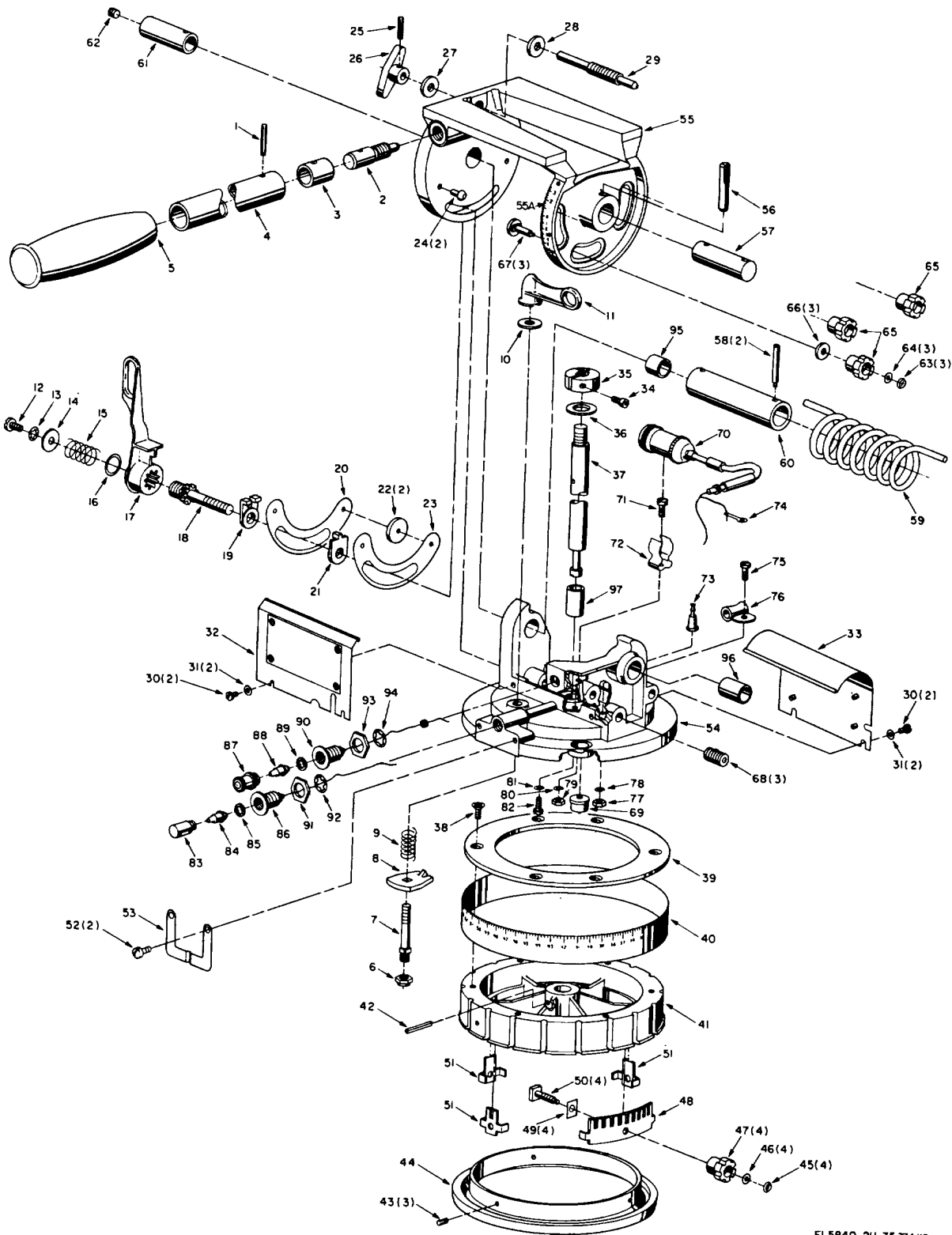

EL5840-211-35-TM-119

Figure 5-2. Tripod head assembly, exploded view.

1	Spring pin 0.125x7/8	50	Square head screw (4)
2	Shoulder pin	51	Detent plate 1 1/2-inch (3)
3	Bushing	52	Binding head screw 8-32x5/16 (2)
4	Handle tube	53	Azimuth indicator clip
5	Flex grip	54	Support casting
6	Hex nut 1/4-28	55	Tripod head casting
7	Stud	56	Grooved pin
8	Clamp	57	Outer shaft
9	Spring	58	Screw pin (2)
10	Washer	59	Spring
11	Azimuth lock handle	60	Center shaft
12	Binding head screw 10-32x3/8	61	Outer shaft
13	Locking ring No. 10	62	Socket head capscrew 1/4-20x1/4
14	Retaining washer No. 10	63	Locking ring (3)
15	Spring	64	Flat washer (3)
16	Ring washer	65	Detent knob (3)
17	Elevation lock handle	66	Washer (3)
18	Spline screw	67	Detent screw (3)
19	Outer dog washer	68	Ball nose plunger (3)
20	Sliding guide	69	Leveling bubble
21	Inner dog washer	70	Tripod lamp cable
22	Spacer (2)	71	Binding head screw 6-32x3/8
23	Sliding guide	72	Connector clip
24	Rivet 3/32-inch (2)	73	Soldering terminal
25	Spring pin 0.094x5/8	74	Ground connector
26	Knob	75	Binding head screw 6-32x3/8
27	Washer	76	Cable clamp
28	Washer	77	Hex nut 6-32
29	Pin	78	Lockwasher No. 6
30	Binding head screw 6-32x1/4 (4)	79	Hex nut 6-32
31	Plain washer No. 6 (4)	80	Lockwasher No. 6
32	Identification plate	81	Lockwasher No. 4
33	Cover plate	82	Binding head screw 4-20x1/4
34	Socket head capscrew 6-32x3/16	83	Lamp cover
35	Collet	84	Bulb
36	Flat washer	85	Rubber ring
37	Shaft	86	Lamp socket
38	Flathead screw -32x3/8 (6)	87	Adjustable lamp cover
39	Connecting ring	88	Bulb
40	Azimuth scale dial	89	Rubber ring
41	Scale support	90	Lamp socket
42	Spring pin 0.182x1	91	Hex nut
43	Spring pin 0.094x1/4 (3)	92	Locking ring
44	Retaining ring	93	Hex nut
45	Locking ring (4)	94	Locking ring
46	Flat washer (4)	95	Bushing 1/2x1/2
47	Detent knob (4)	96	Bushing 1/2x3/4
48	Detent plate 1 3/4-inch	97	Bushing 1/2x3/4
49	Rectangular washer (4)		

Figure 5-2--Continued

w. Insert a long rod, approximately 5/32 inch in diameter, through the hole in the outer hub of the scale support (41) and drive out the spring (42) which secures the shaft (37) to the scale support (41).

x. Drive out the shaft (37) from the scale support (41).

y. Remove the three spring pins (43) which secure the retaining ring (44) to the scale support (41), and separate the retaining ring (44) and scale support (41).

z. Remove the locking ring (45) and flat washer (46) which secure the detent knob (47) of the detent plate to the square head screw (50).

aa. Remove the detent knob (47), 1 3/4-inch detent plate (48), and rectangular washer (49) from the square head screw (50).

NOTE

Do not remove the pad glued to the detent plate (48).

ab. Follow the procedure of z and aa above to disassemble azimuth detents A, B, and

C (TM 11-5840-211-12). In each case, remove the 1/2-inch detent plate (51, fig. 62) instead of the 1 6/4-inch detent plate (48) as in *aa* above.

ac. Remove the two binding head screws (52) which secure the azimuth indicator clip (53) to the support casting (54) and remove the azimuth indicator clip (53).

ad. Drive out the grooved pin (56) which secures the outer shaft (57) to the tripod head casting (55).

ae. Unscrew the two screw pins (68) which secure the two outer shafts (57, 61) to the center shaft (60) and also limit motion of spring (59).

af. Use a 1/8-inch Allen wrench to remove the socket head capscrew (62) from the outer shaft (61).

ag. Insert a long, 1/16-inch diameter rod through the hole which was exposed when the hexagonal socket head screw (62) was removed, and drive out the outer shaft (57).

ah. Insert a 5/16-inch diameter rod into the now open end of the center shaft (60) and drive out the other outer shaft (61).

ai. Lift the tripod head casting (55) away from the support casting (54).

aj. Remove the center shaft (60) and the spring (59) from the upper portion of the tripod head assembly.

ak. Slide the spring (59) off the center shaft (60).

al. Remove the locking ring (63) and flat washer (64) which secure the detent knob (65) of elevation detent A to the detent screw (67, fig. 6-2).

am. Remove the detent knob (65), washer (66), and detent screw (67) of the elevation detent from the tripod head casting (55).

an. Repeat the procedure given in *al* and *am* above to remove elevation detents B and C from the tripod head casting (55, fig. 5-2).

ao. Remove the three ball nose plungers (68) from the support casting (54).

ap. If necessary, remove the plaster of Paris which secures the leveling bubble (69) in the support casting (54) and remove the leveling bubble.

aq. Unsolder all the connections from the soldering terminal (73).

ar. Remove the binding head screw (75), hex nut (77), and lockwasher (78) which secure the cable clamp (76) to the support casting (54).

as. Remove the binding head screw (82) and lockwasher (81) which secure the soldering ter-

minal (73) and the ground connector (74) to the support casting (54), and remove the soldering terminal (73).

at. Pull the tripod lamp cable connector from the connector clip (72, fig. 5-2), and remove the tripod lamp cable (70), together with the ground connector (74) and cable clamp (76) from the support casting (54).

au. Remove the binding head screw (71), hex nut (79), and lockwasher (80) which secure the connector clip (72) to the support casting (54), and remove the connector clip (72).

av. Remove the lamp cover (83), together with the bulb (84) and the rubber ring (85) from the lamp socket (86) of one of the tripod lamps.

aw. Back up the hex nut (91, fig. 2) and unscrew the lamp socket (86), together with the hex nut (91) and locking ring (92) from the support casting (54).

ax. Repeat the procedure given in *av* and *aw* above to remove the adjustable lamp cover (87), bulb (88), rubber ring (89), lamp socket (90), hex nut (93), and locking ring (94) from the support casting (54).

ay. If necessary, drive out the three bushings (95, 96, and 97) from the shaft holes in the support casting (54).

5-40. Disassembly of Tripod Leg Assembly

The directions in a through c below cover the disassembly of the tripod leg assembly after it has been separated from the tripod head assembly (para. 5-38b).

a. Separation of Tripod Legs From Support (10 fig. 5-1).

(1) Remove the spring pin (6) which secures the cap (5) to the bolt (16), and remove the cap (5).

(2) Remove the wingnut (7), washer (8), and (bolt -)(16) from the tripod leg assembly.

(3) Remove the tripod leg from the yoke in, the support (10).

(4) Remove the two special screws (12), two hex nuts (11), and the flathead screw (13) which secure the serrated clamp (14) to the support (10) and remove the serrated clamp (14).

(5) Remove the two bearing sleeves (9, 15) from the yoke in the support (10).

(6) Repeat the procedures in (1) through (5) above to remove the remaining two tripod legs from the support (10).

b. Disassembly of Tripod Legs. Disassemble the individual tripod legs as follows:

(1) Remove the spring pin (18, fig 6-1) which secures the tripod leg tip (17) to the inner leg (19).

(2) Back off the knob (20) of the locking clamp (24) as far as possible and slide the inner leg (19) partially out of the outer leg (21).

(3) Position the inner leg (19) until the rectangular mark on the inner leg (19) is lined up with the pinhole in the locking clamp (24) and is just visible below the outer leg (21).

(4) Drive the spring pin (22) into the inside of the inner leg (19) and slide the inner leg (19) together with the loop clamp (23), out of the outer leg (21).

(5) Slide the loop clamp (23) off the inner leg (19). Compress the loop clamp (28) as soon as it is accessible to facilitate its removal.

(6) Slide the locking clamp (24) off the outer leg (21).

(7) Remove the spring pin (25) which secures the knob (20) of the locking clamp to the stud (26) and separate the knob (20), locking clamp (24), and stud (26).

(8) If necessary, insert a long bar into the open end of outer leg (21) and drive the leg adapter (27) off the other end of the outer leg (21).

(9) Repeat the procedure in (1) through (8) above to disassemble the remaining two tripod legs.

c. Removal of Control Handle Clip (fig. 61). The control handle clip is located on only one of the tripod legs and is used to store the control handle when the radar set is not in use.

(1) Use a 1/8-inch Alien wrench to remove the two socket head capscrews (28), two hexagonal nuts (30), and two plain washers (20) which secure both halves of the clip (31 and 32) to the clamp (33).

(2) Remove both halves of the clip (31 and 32).

(3) Slide the clamp (33) off the outer leg (21).

5-41. Reassembly of Tripod Head Assembly

The directions in *a* through *at* below cover the assembly of a disassembled (para. 5-49) tripod head assembly.

a. If paragraph 5-39*f* and *j* was performed, assemble the sliding guide (23), inner dog washer (21), two spacers (22), and sliding guide (20), and position them on the tripod head casting (55, fig. 6-2).

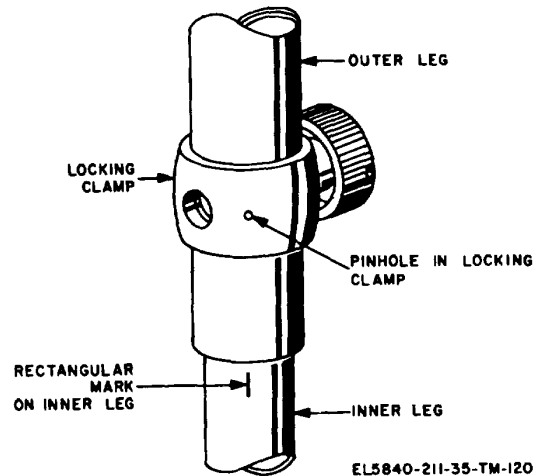

Figure 5-3. Positioning of tripod legs.

b. To secure the items assembled in *a* above, drive two 3/32-inch rivets (24) into the holes in the tripod head casting (55).

c. Assemble the adjustable lamp cover (87), bulb (88), rubber ring (89), lamp socket (90), hex nut (93), and locking ring (94), and install the assembly in the appropriate hole in the support casting (54).

d. Assemble the lamp cover (83), bulb (84), rubber ring (85), lamp socket (86), hex nut (91), and locking ring (92), and install the assembly in the appropriate hole in the support casting (54).

e. Position the soldering terminal (73) and the ground connector (74), which is attached to the tripod lamp cable (70), on the appropriate hole in the support casting (54) and secure the soldering terminal and ground connector with one No. 4 lockwasher (81) and one No. 4-20 x 1/4 binding head screw (82).

f. Install the connector clip (72) on the support casting (54) and secure the connector clip with one No. 6-32 x 3/8 binding head screw (71), one No. 6 lockwasher (80), and one No. 6-32 hex nut (79).

g. Insert the tripod lamp cable connector into the connector clip (72) and position the tripod lamp cable (70) on the support casting (54).

h. Secure the cable clamp (76) attached to the tripod lamp cable (70) to the support casting (54) with one No. 6-32 x 3/8 binding headscrew (76), one No. 6 lockwasher (78), and one No. 6-32 hex nut (77).

i. Solder the center conductor lead from the tripod lamp cable (70) and the two leads from the tripod lamps to the soldering terminal (73).

j. Replace the leveling bubble (69) in the support casting (54) and secure it with plaster of Paris. After the plaster of Paris is dry apply to it a protective coating of varnish.

NOTE

Make sure that the bubble is centered when the support casting is perfectly leveled.

k. Install one 1/2 x 1/2 bushing (95) and two 1/2 x 3/4 bushings (96 and 97), into the appropriate holes in the support casting (54).

l. Insert the three ball nose plungers (68) into the appropriate holes in the support casting (54).

m. Insert the detent screw (67) of elevation, detent (TM 11-5840-211-12) through the proper opening in the tripod head casting (55, fig 5-2) and install the washer (66) and the detent knob (65) on the detent screw (67).

n. Secure the knob (65) by replacing the flat washer (64) and locking ring (63).

o. Repeat the procedure in (*m*) and (*n*) above to replace elevation detents B and C (TM 11-6840-211-12).

p. Replace the spring (59, fig 5-2) on the center shaft (60) and position the center shaft on the support casting (54).

q. Position the tripod head casting (55) on top of the support casting (54).

r. Secure the center shaft (60) to the support casting (54) and tripod head casting (55), by driving the two outer shafts (57 and 61) into the center shaft through the holes in the tripod head casting (55).

NOTE

Line up the holes for the screw pins (58) in all three shafts.

s. Secure the center shaft (60) to the outer shafts (57 and 61) by replacing the two screw pins (58).

t. Secure the shaft assembly to the upper portion of the tripod head casting (55) by replacing the grooved pin (56).

u. Replace the 1/4-20 x 1/4 socket head cap-screw (62) in the outer shaft (61).

v. Assemble the square head screw (50), rectangular washer (49), 1 3/4-inch detent plate (48), and detent knob (47) of azimuth sector scan detent and install the detent on the retaining ring (44, fig. 5-2).

w. Secure the detent to the retaining ring (44) by replacing the flat washer (46) and locking ring (45).

x. Repeat the procedure in steps (*v*) and (*w*) above to install and secure azimuth detents A, B, and C (1/2-inch detent plate (51, fig. 5-2) in each case instead of the 1 3/4-inch detent plate (48)).

y. Secure the retaining ring (44) to the scale support (41) by replacing the three 0.094 x 1/4, spring pins (43).

z. Drive the shaft (37) into the center hole of the scale support (41), line up the pinholes in the shaft (37) and scale support (41), and secure the shaft by replacing the 0.182 x 1 spring pin (42).

aa. Slip the azimuth scale dial (40) around the scale support (41).

NOTE

The orientation of the azimuth scale dial is as shown in figure 5-2.

ab. Install the connecting ring (39) by replacing the six No. 8-32 x 8/8 flathead screws (38).

ac. Position the upper portion of the tripod head assembly on top of the lower portion so that the shaft (37) fits into the hole in the support casting (54).

ad. Install the flat washer (36) and collet (35) on the shaft (37) and secure the collet by tightening the No. 6-32 x 3/16 socket head capscrew/ (34) with a 3/32-inch Allen wrench.

NOTE

Before securing the collet (35), tighten it fully by hand and then back off 1/4 turn.

ae. Install the cover plate (33) on the tripod head assembly and replace the two No. 6-32 x 1/4 binding head screws (30) and two No. 6 plain washers (31).

af. Install the identification plate (32) on the tripod head assembly and replace the two No. 6-32 x 1/4 binding head screws (30) and two No. 6 plain washers (31).

ag. Position the azimuth indicator clip (53) on the tripod head assembly and secure it by replacing two No. 8-42 x 5/16 binding head screws (52).

ah. Position the lamp cover (83) so that the azimuth scale dial (40) is illuminated and lock the hex nut (91) located on the lamp socket (86). Position the adjustable lamp cover (87) so that the notch in the knurled portion is pointed at the center of the leveling bubble (69), and both the leveling bubble (69) and the elevation scale can be illuminated by pointing the slot in the cover into one or the other direction. Secure the

lamp socket (90) in this position by tightening the nut (93).

ai. Replace the washer (28) on the pin (29) of the securing screw and insert the pin through the hole in the tripod head casting (55).

aj. Replace the washer (27) and knob (26) on the pin (29) and secure the knob by replacing the 0.094 x 1/2 spring pin (25).

ak. Replace the outer dog washer (19) and spline screw (18) into the hole in the support casting (54).

al. Replace the elevation lock handle (17) on the spring screw (18) and secure it by replacing the ring washer (16), spring (15), No. 10 retaining washer (14), No. 10 locking ring (18), and a No. 10-32 x 8/8 binding head screw (12) on the other side of the elevation lock handle (17).

am. Install the washer (10) and azimuth lock handle (11) on the tripod head assembly and secure them by replacing the stud (7) through the rectangular hole of the scale support (41).

NOTE

The upper portion of the stud (7) has left-hand thread.

an. Use a screwdriver to adjust the stud (7) so that the bottom edge of the rectangular portion of the stud (7) is exactly 1/32 of an inch above the lower edge of the connecting ring (89), as shown in figure 54.

ao. Assemble and secure the spring (9, fig. 5-4), clamp (8), and 1/4-28 hexagonal nut (6) to the lower portion of the stud (7) through the rectangular hole in the scale support (41).

ap. Check to see that the azimuth lock handle (11) can be tightened fully without interference from the identification plate (31) and that the tripod head assembly can be rotated freely in azimuth with the azimuth lock handle (11) is in the open position.

aq. Assemble the flex grip (5), handle tube (4), bushing (3), and shoulder pin (2) of the

control handle and secure these parts by replacing the 0.125 x 7/8 spring pin (1).

ar. Replace the control handle on the tripod head casting (55).

as. Adjust the ball nose plungers (68) so that their body clears the head of the detent screw (67) by 0.005 to 0.010 inch.

5-42. Reassembly of Tripod Leg Assembly

The directions given in *a* through *c* below cover the assembly of a disassembled tripod leg assembly.

a. Assembly of Control Handle Clip (fig. 6-1).

(1) Clip the clamp (33) onto an outer leg and position the clamp near the center of the leg (21).

(2) Position both halves of the clip (31 and 32) on the appropriate sides of the clamp (38).

(3) Replace the two No. 8-32 x 3/4 socket head capscrews (28), the two No. 8-32 nuts (30), and the two No. 8 plain washers (29) which secure both halves of the clip (31 and 32) to the clamp (33).

b. Assembly of Tripod Legs.

(1) Install the stud (26, fig. 5-1) in the locking clamp (24), and secure the knob (20) to the stud (26) by replacing the 0.078 x 15/16 spring pin (25).

(2) Install the locking clamp (24) on the outer leg (21), align the holes for the 0.094 x 5/16 spring pin (22), and temporarily secure the locking clamp (24) by inserting one No. 4 40 x 1/4 setscrew in the threaded hole in the locking clamp.

(3) Slide the loop clamp (23) and inner leg (19) into the inside of the outer leg (21) and align the pinhole in the loop clamp (23) with the pinhole in the outer leg-(21). Position the inner leg (19) as indicated on figure 5-3.

(4) Replace the 0.094 x 5/16 spring pin (22, fig. 5-1) which secures the loop clamp (23) and locking clamp (24) to the outer leg (21). Remove the setscrew from the loop-locking clamp (24), using a 0.050 Allen wrench.

(5) Install the tripod leg tip (17) at the bottom of the inner leg (19) and replace the 0.126 x 1 spring pin (18).

(6) If the leg adapter (27) was removed, install the leg adapter (27) at the top of the outer leg (21).

NOTE

Put one drop of sealant between the leg adapter (27) and outer leg (21) and let dry for 12 hours before proceeding further.

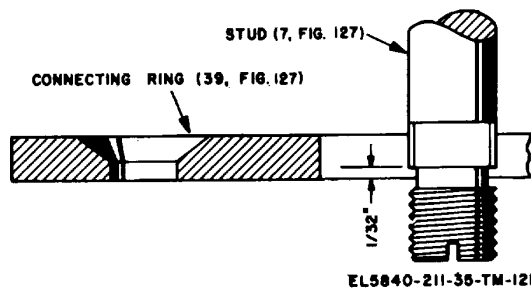

Figure 5-4. Positioning of azimuth lock assembly.

(7) Repeat the procedure in (1) through (6) above to assemble the remaining two tripod legs.

c. *Reassembly of Tripod Legs to Support* (fig. 5-1).

(1) Replace the two bearing sleeves (9 and 15) in the yoke of the support (10).

(2) Install the serrated clamp (14) on the yoke of the support (10) and secure it by replacing the two No. 10-32 x 3/4 special screws (12),

two No. 10-32 hex nuts (11), and the No. 8-32 x 1/4 flathead screw (13).

(3) Install the assembled tripod leg in the yoke of the support (10) and secure it by replacing the bolt (16), washer (8), and wingnut (7).

(4) Secure the wingnut (7) to the bolt (16) by replacing the cap (5) and the .078 x 5/8 spring pin (6).

(5) Repeat the procedure in (1) through (4) above to assemble the remaining two tripod legs to the support (10).

CHAPTER 6

DEPOT MAINTENANCE

6-1. Scope of Depot Maintenance

Depot maintenance consists of those maintenance procedures that are beyond the capability of general support maintenance facilities and are required to return the equipment to a performance standard equivalent to that of new equipment. The maintenance procedures are those indicated for direct and general support plus those procedures that are mechanical and/or structural in nature as required for equipment rebuild.

6-2. Tools and Test Equipment Required

Refer to the basic issue items list (BIIL) and the maintenance allocation chart (MAC) in TM 11-5840-211-12 for a complete list of tools and test equipment authorized. Special test equipment required for maintenance of Radar Set AN/PPS-4A is covered in paragraph 3-14.

**CHAPTER 7
DEPOT OVERHAUL STANDARDS**

Section I. GENERAL

7-1. Applicability of Depot Overhaul Standards

The tests outlined in this chapter are designed to measure the performance capability of a repaired equipment. Equipment that is returned to stock should meet the standards given in these tests.

7-2. Applicable References

a. Repair Standards. Applicable procedures of the depots performing these tests and the general standards for repaired electronic equipment given in TB SIG 335-1, TB SIG 355-2, and TB SIG 355-3 form a part of the requirements for testing this equipment.

b. Technical Publications. The following technical publications are applicable to this equipment.

Equipment and subject

Publication

Operator and Organizational Maintenance Manual Including Repair Parts and Special Tool Lists: Radar Set AN/PPS-4A.	TM 11-5840-211-42
Field and Depot Maintenance Manual: Telescope, Elbow M16A1D, M16A1F, M16A1G, M116, and M116C.	TM 9-140--288-36
Operator's, Organizational, Field, and Depot Maintenance Manual: Battery, Storage BB-422/U.	TM 11-614 0-3-1-

c. Modification Work Orders. Perform all applicable modification work orders pertaining to this equipment before making the tests specified. Refer to DA Pam 310-7 which lists all available MWO's.

7-3. Test Facilities Required

The following equipment, or suitable equivalents, will be employed in determining compliance with this specific standard.

Equipment	Federal Stock No.	Qty reqd	Applicable literature
Generator, Signal AN/URM-127	6625-783-5965	1	TM 11-6625-683-15
Detector Mount MK-2569/U	5895-752-5311	1	
Dummy Load DA-146/U	5895-538-7328	1	
Voltmeter, Electronic AN/USM-98	6625-753-2115	1	TM 11-6625-438-10
Oscilloscope AN/USM-281	6625-228-2201	1	TM 11-6625-535-15
Power Supply PP-1104C/G	6130-542-6385	1	TM 11-6130-246-12
Test Set TS-147D/UP	6625-256-1377	1	TM 11-1247A
Range Calibrator AN/UPM-11A	6625-503-0692	1	TM 11-6625-310-15
Telephone Test Set AN/PTM-6	6625-229-1048	1	TM 11-2062
Test Set TS-147D/UP	6625-196-5302	1	TM 11-1247B
Voltmeter, Electronic ME-30U	6625-669-0742	1	

b. Additional Equipment.

Equipment	Federal Stock No.	Qty reqd	Applicable literature
Battery, Storage BB-422/U	6140-789-2118	1	TM 11-6140-203-15-1
Cable R-9B/U (6 ft)	6145-170-7837	1	
Control Panel Support Fixture	Prefabricated	1	Fig. 3-5
Connector U-79/U	5935-201-4323	1	
Maintenance Kit, Electronic Equipment MK-541/PPS-4	5840-893-1929	1	TM 11-5840-280-15P

Section II. TESTS

7-4. General Test Requirements

All tests will be conducted under the following conditions:

- a. Input power to the equipment should be 24 volts direct current unless changed by the test procedure.
- b. The equipment should be allowed a warm-up period of at least 3 minutes before any test readings are taken.
- c. All sub-units should be connected to their respective connectors.
- d. Test connections are indicated in figure 7-1.

7-5. Preliminary Operations**CAUTION**

Care should be taken in handling the control panel to prevent damage to meter M101, the strobe unit, and exposed wiring.

- a. Release the four trunk-type latches that fasten the control panel on the receiver-transmitter, and remove the control panel.
- b. Place the control panel in the support fixture (fig. 3-5).
- c. Connect the repair patch cord between P101 on the control panel and receptacle J101 on the rear of the receiver-transmitter.

CAUTION

Care should be taken to prevent denting the reflector or damaging the dipoles of the antenna feed assembly.

- d. Release the four trunk-type latches that fasten the front section (radome) on the receiver-transmitter, and remove the radome.
- e. Remove the antenna feed assembly (fig. 3-50) and replace with Dummy Load DA-146/U. Make sure that the DA-146/U is correctly mated.

WARNING

The primary function of the interlock switch is to protect personnel against high voltages. Observe warning procedures in paragraph 37.

- f. Disable interlock switch S1 (fig. 3-50) by pulling the interlock shaft to its full forward position.
- g. Set the control panel switches as follows: POWER switch OFF, VOLTAGE ADJ switch, POS 1, PANEL LIGHTS switch OFF, TRIPOD LIGHTS switch OFF, and STROBE switch OFF.

7-6. Power Supply Test**CAUTION**

When the power source is other than a 24-volt battery, make sure that the peak voltage applied to the AN/PPSAA does not exceed 24 volts. Damage to the radar set will result if a voltage higher than 24 volts is applied. Radar Set AN/PPS-4A has a negative (-) input chassis ground.

- a. Connect variable power supply to control panel 24VDC BAT ONLY receptacle and Headset H-183/PPA-4 to control panel HEADSET receptacle.

- b. Connect Voltmeter, Electronic AN/USM-98 between TB1 terminal 4 and ground. Terminal board TB1 terminal 4 is positive 270 volts with respect to ground.

- c. Adjust variable power supply for lowest output.

- d. On the control panel, set the POWER switch to STANDBY and depress the BATTERY TEST button. Slowly adjust variable power supply until RANGE EXTENSION METERS needle reads in the center of the red portion. Release the BATTERY TEST button and allow a 8-minute warm-up.

- e. Turn POWER switch to TRANSMIT, Voltmeter, Electronic AN/USM-98 connected *b* above should read +270 volts. If the applicable voltage is not obtained, adjust variable power supply until the applicable voltage is present. Depress and hold the BATTERY TEST button. If the RANGE EXTENSION METERS needle is not in the center of the red portion, adjust R1005 (fig. 3-34) on the strobe unit until the needle is centered.

- f. Decrease the output of the variable power supply and set the VOLTAGE ADJ switch to position 2. Slowly increase the output of the variable power supply until the AN/USM-98 reads +270 volts dc. Press the BATTERY TEST button. The RANGE EXTENSION METER should read in the center of the red portion of the meter. Slightly readjust R1005 to obtain a center reading.

- g. Repeat the procedure given in f above for VOLTAGE ADJ switch position 3, 4, 5, 6, and 7.

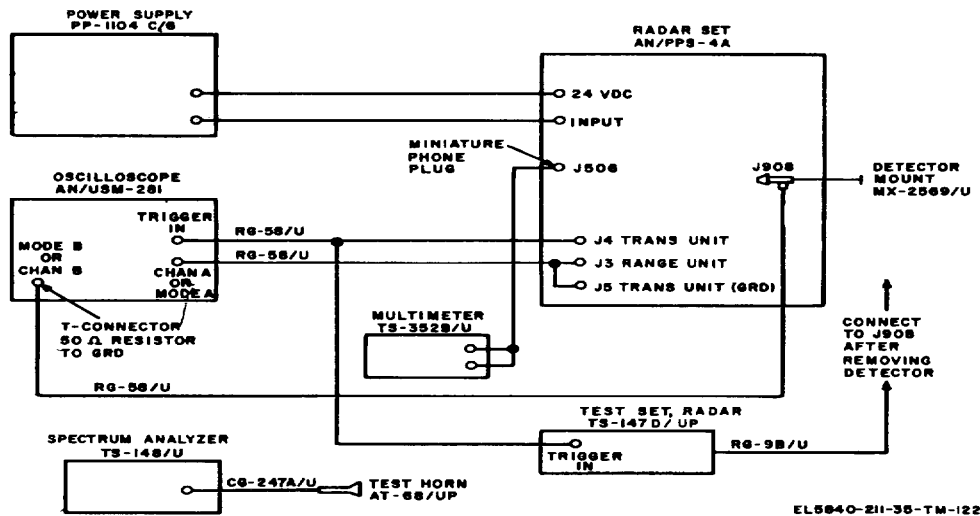

Figure 7-1. Test setup.

NOTE

As the VOLTAGE ADJ switch is positioned from a low number to a higher number, make sure that the output of the variable power supply has been lowered before switching the VOLTAGE ADJ switch.

h. Return the VOLTAGE ADJ switch to position 3, and obtain the correct test indications by repeating the procedures given in e above and i below.

i. Check the voltages at terminal board 1 TB-1, fig. 3-13 using the chart below.

Voltage	TB-1 Term	Limits	Remarks
24 vdc	1	22.8 to 25.2 vdc	
AGC voltage	2	-2.6 to -5.5 vdc	Volume control full cw
AGC voltage	2	+1.2 maximum	Volume control full cw
+250 vdc	3	237 to 262 vdc	
+270 vdc	4	269 to 271 vdc	
+120 vdc	5	114 to 126 vdc	
+24 vdc	6	22.8 to 25.2 vdc	
Ground dc	7 and 8	0	
-20 vdc	9	-19 to -21 vdc	
-150 vdc	10	-145.5 to -157 vdc	
6.3 vac	11	12 to 13.2 peak to peak	Measure with respect to pin 12
6.3 vac common	12	12 to 13.2 peak to peak	
7.0 vac	13	13 to 14.5 peak to peak	Measure with respect to pin 14
7.0 vac	14	13 to 14.5 peak to peak	
+24 vdc	15	+19 to +27.5 vdc	Depends on power source

7-7. Transmitter Frequency, Pulse Width, Duty Cycle, Repetition Rate, and Power Output Tests

a. *General.* Set the radar set and test equipment as indicated in figure 7-1.

b. *Transmitter Frequency Test.* Tune the magnetron to 9, 150 MHz. If necessary, loosen the screw that secures the MAG TUNER to the

tuning shaft and adjust the tuning shaft until 9, 150 MHz is obtained. Measure the magnetron frequency at the peak of the displayed spectrum. Center the MAG TUNER on the magnetron shaft and tighten the setscrew until it is secure.

c. *Pulse Width Test.* Connect Detector Mount MX3569/U to J908. Connect the vertical input of the oscilloscope to the MX-2569/U. Set the

oscilloscope controls to view a 0.2-microsecond pulse width. The width of the pulse should be 0.2 to 0.22 microseconds wide measured at the 50 percent points.

d. *Duty Cycle and Repetition Rate Tests.* Set the oscilloscope controls to measure the time between the leading edges of the two pulses. Adjust R202 on the transmitter unit (fig. 3-14) as given in the chart below to maintain a constant duty cycle of 0.0006. Interpolate values from the chart if necessary.

Measured width (c above) (μsec)	Pulse Repetition rate
	Duty Cycle: .0006 (μsec)
0.18	800
0.19	317
0.20	38
0.21	350
0.22	367

e. *Average Power Output Test.* Disconnect the detector mount from J908 and connect the power meter to J908 by means of the RG-9B/U cable after zeroing the power meter. Set the POWER switch to TRANSMIT, depress the BATTERY TEST button, and the RANGE EXTENSION METERS needle should be in the center of the red portion. The minimum average power output with a duty cycle of .0006, should be 24 dbm. Adjust R207 on the transmitter unit (fig., 3-14), if necessary, to obtain maximum output.

7-8. Local Oscillator and Automatic Frequency Control Tests

The local oscillator frequency and the automatic frequency control tests are performed in conjunction with one another.

a. Set the POWER switch to STAND BY and the AFC/MFC switch on the audio unit (fig. 3-58) to MFC.

CAUTION

Jack J604 of the audio unit (fig. 358) must not be shorted to or connected with a low resistance to ground; damage to the unit will result.

b. Connect Multimeter TS-352B/U between J604 of the audio unit (fig. 3-8) and ground and adjust R632 until the meter reads -106 volts dc.

c. Connect Multimeter TS-352B/U to J506 on the IF amplifier unit (fig. 3-13); use the 0- to 2.5-milliampere scale. The meter reading should not exceed 1 milliampere.

d. Reverse the polarity of Multimeter TS-352B/U and connect to J507 on the IF amplifier unit (fig. 3-13); use the 0- to 2.5-milliampere scale. The meter reading should not exceed 1 milliampere and should be of reverse polarity and approximately the same value of c above.

CAUTION

The local oscillator (klystron) tube shell is +270 volts dc in respect to chassis ground. The klystron is located near the local oscillator attenuator (fig. 3-50) and extreme caution must be exercised to prevent shock when adjusting the klystron tuning bow or the local oscillator attenuator.

e. Tune the local oscillator (klystron) for maximum current reading by varying the klystron tuning knob (use the klystron tuning tool (fig. 6-50)). If the current starts to exceed 1 milliampere, adjust the local oscillator attenuator to reduce the current. Keep adjusting the klystron tuning bow and local oscillator attenuator until maximum meter (less than 1 milliampere) reading with maximum attenuation is obtained.

f. Set the POWER switch to TRANSMIT and the MAG TUNER knob to midrange of its mechanical adjustment.

g. With Spectrum Analyzer TS-148/UP pick-up horn positioned as shown in figure 8-50, adjust the TS-148/UP controls to observe two spectras each of the magnetron and klystron frequencies.

h. Select the magnetron and klystron images which are higher in frequency. Measure the differences in frequencies (fig. 3-61). If the klystron frequency is not 30 MHz above the magnetron frequency, turn the klystron tuning knob. If the 30-MHz difference cannot be obtained (klystron stopped oscillating, indicated by loss of crystal current), adjust R632 in the direction which will start or increase crystal current.

NOTE

Adjusting R632 changes the reflector plate voltage (measured at J604 on the audio unit). This voltage should stay within -95 to -115 volts with an indication of crystal current occurring at the proper 30-MHz difference.

i. Set the AFC/MFC switch to the AFC position (fig. 3-58). The system should lock on. With the system locked on in the AFC operation, readjust the klystron tuning bow for maximum crystal current without exceeding 1 milliampere (e above).

j. Note the position of the klystron frequency on the TS-148/UP and set the AFC/MFC switch to the MFC position. If a frequency shift of the klystron occurs, adjust R632 (fig. 3-58) on the audio unit (keeping within the reflector voltages in note, h above) until the frequency of the klystron is the same in either position of the AFC/MFC switch.

k. When the AFC/MFC switch is positioned first in the MFC position and then in the AFC position and no klystron frequency shift occurs and the current at J506 and J507 remains constant, check the frequency difference between the magnetron and klystron. If the difference is 30+1 MHz, proceed to l below. If the difference is something other than 30 MHz, perform the procedures given in h, i, and j above.

l. Set the AFC/MFC switch to the AFC position and vary the MAG TUNER knob through- out its range. The AFC switch should remain locked on.

m. With the BATTERY TEST button de- pressed, lower the input voltage until the needle on the RANGE EXTENSION METERS reads to the left edge of the red area. Release the BAT- TERY TEST button. The AFC should remain locked on.

n. With the BATTERY TEST button de- pressed, increase the input voltage until the needle on the RANGE EXTENSION METERS reads to the right edge of the red area. Release the BATTERY TEST button. The AFC should remain locked on.

o. With the BATTERY TEST button de- pressed, adjust the input voltage until the needle on the RANGE EXTENSION METERS reads in the center of the red portion. Release the BATTERY TEST button.

NOTE

An accurate means to determine when the AFC is locked on is to observe the output of the afc system (jack J701 on the afc unit (fig. 3-59)). A stable wave- form (B, fig. 3-27) should be present.

7-9. Rangemark Check

a. Set the POWER switch to the RANGE position and rotate the RANGE CONTROL throughout its range.

b. Successive deflections of the RANGE EX- TENSION METERS should be obtained at ap- proximately 1,000-meter intervals following the first rangemark that occurs at approximately 500 meters.

NOTE

An accurate means of observing range- marks and their position can be accom- plished by connecting the oscilloscope to J703 of the range unit (fig. 3-55). Set the POWER switch to TRANSMIT and a rushing sound should be heard in the headset, and its intensity should be varied by the VOLUME control on the front panel.

7-10. Strobe Check

Set the STROBE switch to the LONG position; the RANGE EXTENSION METERS should indicate a sweep of 10 +0.5 seconds. Set the STROBE switch to the SHORT position; the RANGE EXTENSION METERS should indicate a sweep of 5 +0.1 seconds. Strobe duration should be 500 ± 10 meters.

7-11. Receiver Tests

a. *Threshold Adjustment.* Adjust the TS-147D/UP as follows:

- (1) DBM dial control fully counterclockwise.
- (2) SIGNAL WIDTH control fully counterclockwise.
- (3) Set REC-TRANS switch to TRANS.
- (4) PHASE control centered.
- (5) Turn SET ZERO control until meter reads SET ZERO.
- (6) Set REC-TRANS switch to REC.
- (7) Adjust VOLUME control for 3/4 volt of grass on the oscilloscope.
- (8) Couple the signal from RF jack on TS 147D/UP to J908 on radar set; use a RG--B/U cable.
- (9) On the TS-147D/UP, turn the DBM dial control to read -55 DBM.
- (10) Tune FREQUENCY control on the TS- 147D/UP for maximum signal on the oscilloscope.
- (11) Adjust the PHASE and DBM controls on the TS-147D/UP for a saturated signal within the range of the range gate.
- (12) Turn the RANGE CONTROL on the radar set until the range gate appears in the center of the signal on the oscilloscope.
- (13) Adjust R615 on the audio unit (fig. 3-58) for a 1.5-volt peak-to-peak signal on the oscilloscope.

b. *Receiver Sensitivity.*

- (1) On the radar set, rotate the RANGE CONTROL so that the signal is un gated.

(2) On the TS-147D/UP, turn the SIGNAL WIDTH control clockwise.

(3) On the TS-147D/UP, adjust the PHASE control for maximum distortion on the oscilloscope.

(4) Remove the RG-9B/U cable from the RF jack on the TS-147D/UP.

(5) On the TS-147D/UP, adjust the POWER SET control until the meter reads SET POWER.

(6) Reconnect the RG-9B/U cable from the RF jack on the TS-147D/UP.

(7) On the TS-147D/UP, adjust the SIGNAL WIDTH control counterclockwise.

(8) On the TS-147D/UP, adjust the DBM control for a 1.5-volt signal on the oscilloscope. Reading of the DBM dial plus the dbm loss of the RG-9B/U cable and directional coupler should exceed -87 dbm.

c. Doppler Sensitivity.

(1) Connect earphones to the front panel of the radar set.

(2) Rotate the RANGE CONTROL hand-wheel to some range beyond 100 meters. A rushing sound should be audible in the earphones, varying in intensity with the varying of the VOLUME control.

(3) Connect the RF cable of Range Calibrator AN/UPM-11A to directional coupler jack J908 and tune the AN/UPM-11A to the operating frequency of the radar set according to instructions given in TM 11-6625-310-15 until rangemarks from the AN/UPM-11A appear on the oscilloscope.

(4) Observe the first rangemark. Make sure that it is not being gated.

(5) Reduce the level of the first range-mark to three-fourths of its level limit by adjusting the VOLUME control on the radar set.

(6) Connect Generator, Signal AN/URM-127 to the external modulator input jack of the AN/UPM-11A, and adjust the AN/URM-127 for minimum output at 100 Hz.

(7) Measure the amplitude voltage of the ungated, unmodulated first rangemark on the oscilloscope.

(8) Adjust the output control of the AN/URM-127 until the peak-to-peak modulation of the top of the rangemark is 0.1 volt. This modulation is due to the introduction of the AN/URM-127 signal.

(9) Adjust the VOLUME control on the radar set until the noise level (baseline) is shifted by approximately 0.3 volt.

(10) Gate the first rangemark and listen for audio tones in the headset.

(11) Presence of audio in the headset indicates a satisfactory doppler sensitivity. Repeat the procedures given in (6) through (10) above for 400 and 1,000 Hz.

d. Range Calibration. Range calibration data appearing on the front panel RANGE CALIBRATION plate should be considered valid for all equipment being checked out by this procedure VI unless in the course of testing it has been necessary to exchange subunits. In such a case, the range calibration procedure detailed in paragraph 3-52 will have to be performed and new data recorded on the RANGE CALIBRATION plate.

e. Range Linearity Adjustment.

(1) On the radar set, position the POWER switch to the RANGE position, the STROBE switch to the OFF position, and the VOLUME control fully clockwise.

(2) Turn the RANGE CONTROL hand-wheel to set the RANGE EXTENSION METERS indicator to the value specified on the RANGE CALIBRATION plate for the first mark.

(3) Depress and adjust the RANGE CALIBRATION 1ST MARK knob until the needle of the RANGE EXTENSION METERS meter deflects to a minimum value.

(4) Release the RANGE CALIBRATION 1ST MARK knob.

(5) Turn the RANGE CONTROL hand-wheel to set the RANGE METERS indicator at 3,500 meters.

(6) Depress and adjust the RANGE CALIBRATION 7TH MARK knob until the needle of the RANGE EXTENSION METERS meter deflects to a minimum value.

(7) Release the RANGE CALIBRATION 7TH MARK knob.

(8) Estimate or measure the present air temperature.

(9) Turn the RANGE CONTROL hand-wheel to set the RANGE METERS indicator to the value specified on the RANGE CALIBRATION plate for the 7TH MARK and the prevailing temperature.

(10) Depress and slowly adjust the RANGE CALIBRATION 7TH MARK knob until the needle of the RANGE EXTENSION METERS meter deflects to a minimum value.

NOTE

The RANGE CALIBRATION 7TH MARK knob will require only a slight adjustment. It is possible to obtain two deflection points. The correct deflection point is the one closest to the setting ob-

with a sputtering frying type noise, replace dial-channel limiter V903.

TM 11-5840-211-35

tained in i above. The performance of (11) below assures that the radar set is calibrated on the proper mark.

(11) Turn the RANGE CONTROL hand-wheel until the RANGE METERS indicator reads 3,500 meters. The needle of the RANGE EXTENSION METERS meter should deflect to a minimum value within ± 50.0 meters of the 3,500-meter indication.

(12) Recheck the calibration accuracy by performing (2), (8), and (9) above. The needle of the RANGE EXTENSION METERS meter should deflect to a minimum value within ± 8 meters of the range value specified on the RANGE CALIBRATION plate. If the calibration accuracy is not within this tolerance, readjust the RANGE CALIBRATION 1ST MARK and RANGE CALIBRATION 7TH MARK knobs ((2) through (11) above).

7-12. Dual Channel Limiter Test

a. Remove all test equipment and completely reassemble the radar set and perform an operational test.

b. During normal operation, if the radar set is excessively noisy (normal background noise excluded)

7-13. Headset H-183/PPS-4 Test

a. Audio Response Test.

(1) Terminate the output of the AN/URM-127 with a 20-ohm resistor.

(2) Connect the ME-30/U to monitor the output of the AN/URM-127.

(3) Connect the H-183/PPS-4 to the out-put of the AN/URM-127; use connector U-79/U.

(4) Adjust the output of AN/URM-127 until a -10 db is indicated on the ME-30/U.

(5) Vary the AN/URM-127 output from 200 to 2,000 Hz.

(6) These frequencies (5) above) should be heard in the headset.

(7) Set the AN/URM-127 for an output of 400 Hz and gently pull and twist the headset cable and listen for intermittent operation.

b. Headset Performance Test.

(1) Connect Headset H-183/PPS-4 to Telephone Test Set AN/PTM-6; use Connector U-181/U. Connect one lead to the RECEIVER and the other lead to the COMMON binding posts.

(2) Set the AN/PTM-6 controls as indicated in the chart below.

Dial control Settings			Equalizer		Keys 1 through 8		Push to operate	
D2 2	D4 7	D5 1	S2 1N	1 LBPE	2 REC	7 AC	8 REC	9 Operate

NOTE Keys not listed remain in unoperated position.

(3) Meter reading should read to the right of -10 db.

Change 3 7-7

COLOR CODE MARKING FOR MILITARY STANDARD RESISTORS

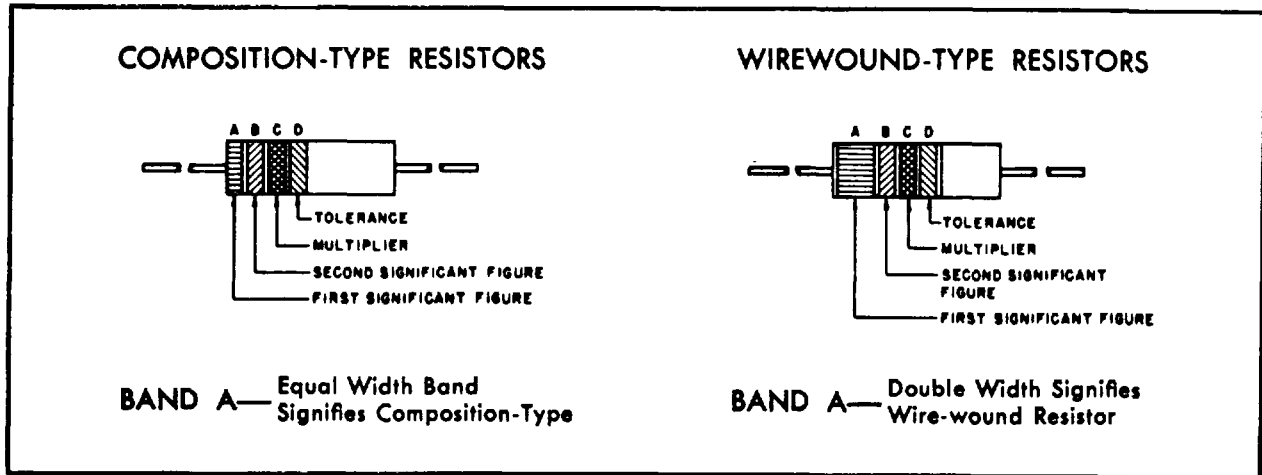

COLOR CODE TABLE

BAND A		BAND B		BAND C		BAND D*	
COLOR	FIRST SIGNIFICANT FIGURE	COLOR	SECOND SIGNIFICANT FIGURE	COLOR	MULTIPLIER	COLOR	RESISTANCE TOLERANCE (PERCENT)
BLACK	0	BLACK	0	BLACK	1		
BROWN	1	BROWN	1	BROWN	10		
RED	2	RED	2	RED	100		
ORANGE	3	ORANGE	3	ORANGE	1,000		
YELLOW	4	YELLOW	4	YELLOW	10,000	SILVER	± 10
GREEN	5	GREEN	5	GREEN	100,000	GOLD	± 5
BLUE	6	BLUE	6	BLUE	1,000,000		
PURPLE (VIOLET)	7	PURPLE (VIOLET)	7				
GRAY	8	GRAY	8	SILVER	0.01		
WHITE	9	WHITE	9	GOLD	0.1		

EXAMPLES OF COLOR CODING

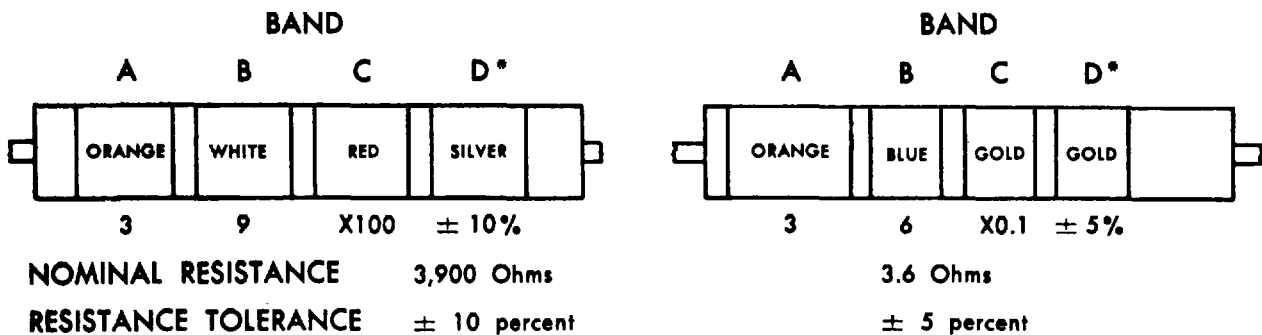

*If Band D is omitted, the resistor tolerance is ± 20%, and the resistor is not Mil-Std.

STD-R2

Figure 7-2. Color code markings for MIL-STD resistors.

APPENDIX A

REFERENCES

Following is a list of applicable references available to the field and depot maintenance technician of Radar Set AN/PPS-4A:

DA Pam 310-4	Index of Technical Publications, Technical Manuals, Technical Bulletins, Supply Manuals (Types 7, 8, and 9), Supply Bulletins, and Lubrication Orders.
DA Pam 310-7 SB 11-573	US Army Equipment Index of Modification Work Orders. Painting and Preservation Supplies Available for Field Use for Electronics Command Equipment.
TB SIG 355-1	Depot Inspection Standard for Repaired Signal Equipment.
TB SIG 355-2	Depot Inspection Standard for Refinishing Repaired Signal Equipment.
TB SIG 355-3	Depot Inspection Standard for Moisture and Fungus Resistant Treatment.
TB 43-0118	Field Instructions for Painting and Preserving Electronics Command Equipment, Including Camouflage Pattern Painting of Electrical Equipment Shelters.
TM 11-1247B	Test Set TS-147D/UP.
TM 11-2062	Test Sets I-142, I-142A, I-142B, and Telephone Test Set AN/PTM-6.
TM 11-5840-28014P	Operator's, Organizational, Direct Support, and General Support Maintenance Repair Parts and Special Tools Lists (Including Depot Maintenance Repair Parts and Special Tools): Maintenance Kit, Electronic Equipment MK-541/PPS-4, FSN 5840-893-1929.
TM 11-6130-246-12	Operator's and Organizational Maintenance Manual: Power Supply PP-1104C/G (NSN 6930-00-542-6385) (with Instructions for Use as Battery Charger).
TM 11-6140-203-15-1	Operator's, Organizational Direct Support, General Support, and Depot I Maintenance Manual: Aircraft and Nonaircraft Nickel-Cadmium Batteries (General).
TM 11-6625-200-15	Operator's Organizational, Direct Support, General Support, and Depot Maintenance Manual: Multimeters ME-26A/U (NSN 6625-00-360-2493), ME-26B/U and ME-26C/U (NSN 6625-00-646-9409), and ME-26D/U (NSN 6625-00-913-9781).
TM 11-6625-203-12	Operator's and Organizational Maintenance Manual: Multimeter AN/URM-105 and AN/URM-105C (Including Multimeter ME-77/U and ME-77C/U).
TM 11-6625-283-12	Operator and Organizational Maintenance Manual: Signal Generators I TS-452B/U and TS-452C/U.
TM 11-6625-310-15	Operation and Maintenance: Range Calibrator Set AN/UPM-11A.
TM 11-6625-320-12	Operator's and Organizational Maintenance Manual: Voltmeter, Meter ME-30A/U and Voltmeters, Electronic ME-30B/U, ME-30C/U, and ME-303E/U.

TM 11-6625-366-15	Operator's, Organizational, Direct Support, General Support, and Depot Maintenance Manual: Multimeter TS-352B/U.
TM 11-6625-435-12	Operator and Organizational Maintenance Manual: Generator, Pulse, SG-366/U.
TM 11-6625438-15	Organizational, Direct Support, General Support, and Depot Maintenance Manual: Voltmeter, Electronic AN/USM-98.
TM 11-6625-535-15	Operator, Organizational, Direct Support, General Support, and Depot Maintenance Manual: Oscilloscope AN/USM-140A.
TM 11-6625-535-15-1	Organizational, Direct Support, General Support, and Depot Maintenance Manual (Including Repair Parts and Special Tool Lists): Oscilloscopes AN/USM-140B, AN/USM-140C, AN/USM-141A, and AN/USM-141B.
TM 11-6625-539-15	Operator, Organizational, Field and Depot Maintenance Manual: Transistor Test Set TS-1836/U.
TM 11-6625-683-15	Operator's, Organizational, Direct Support, General Support and Depot Maintenance Manual: Signal Generator AN/URM-127 (NSN 6625-00-783-5965).
TM 38-750	The Army Maintenance Management System (TAMMS).

Change 4 A-2

INDEX

	Paragraph	Page
Adjustment:		
Afc control system -----	3-38	3-62
Afc unit-----	3-40	3-63
Afe Sweep -----	2-41	3-64
Age system -----	3-50	3-69
Bandwidth-----	3-36	3-56
Duty cycle -----	3-50	3-49
Gain -----	3-36	3-56
Klystron-----	3-41	3-64
Magnetron -----	3-33, 3-41	3-55, 3-64
Power converter-----	3-47	3-69
Power output-----	3-32	3-65
Pulse width -----	3-32	3-55
Range calibration -----	3-32	3-70
RANGE EXTENSION METER meter - -----	3-28, 3-44	3-54,3-68
Range linearity-----	3-29	3-64
RANGE METERS indicator-----	3-27	3-52
Ranging system -----	3-42	3-69
Receiver threshold -----	3-51	3-70
Receiving system -----	3-34	3-56
Repetition rate -----	3-32	3-55
Strobe _ -----	3-45	3-68
Transmitting system -----	3-30	3-54
Alignment (See Adjustment)		
Block Diagrams:		
Afc system (fig. 2-19) -----		2-31
Age system (fig. 2-31) -----		2-51
Audio system (fig. 2-30) -----		2-49
Complete (fig. 7-5) -----		7-13
Power converter system (fig. 2-33) - -----		2-55
Ranging system (fig. 2-23) -----		2-38
Receiving system (fig. 2-15) -----		2-24
Rf system (fig. 2-7) -----		2-17
System functional (fig. 7-4) -----		7-11
Transmitter system (fig. 2-2) -----		2-9
Disassembly:		
Tripod head assembly -----	5-38	5-24
Tripod leg assembly -----	5-40	5-30
Exploded Views:		
RF system (fig. 3-71) -----		3-88
Tripod head assembly (fig. 5-2) -----		5-28
Tripod leg assembly (fig.) -----		6-31
Reassembly (See Disassembly).		
Removal:		
Afc control system -----	3-65, 5-31	3-75, 5-19
Age system -----	5-34	5-22
Audio system -----	5-53	5-21
Audio unit -----	3-64	3-75
Azimuth indicator -----	3-70	3-94
Control panel -----	3-59	3-73
IF amplifier -----	3-63	3-74
Microwave unit -----	3-67	3-78
Potentiometer R103-----	5-28	5-17

	Paragraph	Page
Power converter system -----	3-66, 5-35	3-76, 5-22
Radome -----	3-59	3-73
Range unit -----	3-62	3-74
Ranging system -----	5-32	5-21
Receiving system -----	3-69, 5-36	3-93, 5-23
Strobe unit S80 -----	3-68	3-86
Transmitter-----	3-60	3-73
Tripod leg assembly -----	3-61, 5-30	3-74, 5-19
Repair:		
Afc control system -----	5-31	3-94
Age control system - -----	5-34	5-22
Audio system - -----	5-33	5-21
Cables -----	3-11	3-6
Case-----	3-56	3-73
Headset 55 -----	3-55	3-73
Microwave unit 3-58-----	3-58	3-73
Parts substitution-----	3-12	3-8
Potentiometer R103 -----	5-28, 5-29	5-17, 5-18
Power converter system -----	5-35	5-22
Ranging system -----	5-32	5-21
Receiving system -----	5-36	5-23
Replacing parts -----	3-6	3-4
Special purpose cables -----	3-54	3-73
Strobe unit -----	3-57	3-73
Transmitting system -----	5-30	5-19
Replacement (See Removal).		
Schematic Diagrams:		
Afe unit (fig. 7-8) -----		7-19
Age system (fig. 2-2) -----		2-53
Antenna (fig. 2-13) -----		2-23
Audio unit (fig. 7-11)-----		7-2
Balanced signal mixer (fig. 2-18) -----		2-27
Basic timing circuit (fig. 2-1)-----		2-4
BATTERY TEST switch (fig. 25- -----		2-61
Control circuit power distribution (fig. 234) -----		2-57
Control panel (fig. 7-13) - -----		7-29
Delay line (fig. 2-22) -----		2-86
Dummy mixer (fig. 8-4) - -----		3-10
HEADSET receptacles (fig. 2-37) -----		2-62
IF amplifier unit (fig. 7-7) -----		7-17
Interconnection (fig. 7-14) -----		7-81
Local oscillator (fig. 2-17) -----		2-26
Long strobe (fig. 2-26) -----		2-43
Microwave assembly (fig. 2) -----		2-11
Normal node (fig. 2-29) -----		2-45
Power converter (fig. 7-12) -----		7-27
RANGE CONTROL and CALIBRATION (fig. 2-36) -----		2-62
Range unit (fig. 7-9) -----		7-21
Short strobe (fig. 2-27)-----		2-44
Strobe unit (fig. 7-10) -----		7-23
Transmitter unit (fig. 7-6)-----		7-15
Afc unit (fig. 8-25)-----		3-33
Audio unit (fig. 3-26) -----		3-33
Range unit (fig. 6) -----		3-49
Ranging system (fig. 335) -----		3-48
Testing		
Depot:		
Afc -----	7-8	7-4
Dual channel limiter -----	7-12	7-7
Duty cycle -----	7-7	7-3
General requirements-----	7-4	7-2
Headset-----	7-18	7-7
Local oscillator -----	7-8	7-4

Power output -----	7-7	74
Power supply -----	7-6	7-2
Preliminary operations -----	7-5	7-2
Pulse width -----	7-7	7-8
Rangemark -----	7-9	7-4
Receiver - -----	7-11	7-6
Repetition rate -----	7-7	7-8
Strobe -----	7-10	7-5
Transmitter frequency -----	7-7	7-8
Direct Support:		
Ac output -----	4-22	4-10
Afc system -----	4-9, 4-10	4-4
Age system -----	4-18	4-8
Audio gain -----	4-17	4-7
Audio system -----	4-16	4-7
Complete system -----	4-23	4-11
Dc output ___ -----	4-21	4-9
Detector -----	4-15	4-6
Doppler sensitivity -----	4-25	4-12
Long strobe -----	4-13	4-6
Magnetron current -----	4 5	4-2
Magnetron filament voltage -----	4-3	4-1
Power converter system -----	4-19	4-8
Power output -----	4-6	4-2
Pulse width -----	4-6	4-2
RANGE EXTENSION METERS meter -----	4-20	4-8
Range gate -----	4-14	4-6
Ranging system -----	4-11	4-5
Receiver sensitivity -----	4-8	4-3
Receiver threshold -----	4-24	4-11
Receiving system -----	4-7	4-3
Repetition rate -----	4-6	4-2
Short strobe -----	4-12	4-5
Transmitter system -----	4-2	4-1
Trigger output -----	4-4, 4-5	4-2
General Support (See Direct Support). Theory:		
Afc System:		
Block diagram -----	2-40	2-30
Discriminator -----	2-48	2-32
IF amplifier -----	2-42	2-30
Mixer -----	2-41	2-30
Precision rangemarkers -----	2-46	2-35
Search and control -----	2-45	2-34
Video amplifier -----	2-44	2-34
Age system		
Amplifier Q604 -----	2-61	2-51
Block diagram -----	2-59	2-50
Diode CR602 -----	2-60	2-50
Emitter follower Q605 -----	2-62	2-51
Audio system		
Audio amplifier -----	2-56	2-48
Audio transformer -----	2-57	2-50
Block diagram -----	2-55	2 48
RF filters -----	2-57	2-50
Control System:		
BATTERY TEST switch -----	2-69	2-59
HEADSET receptacles -----	2-72	2-62
Lamp switches -----	2-73	2-62
Power receptacle, fuse, and switch -----	2-68	2-58
RANGE CALIBRATION controls -----	2-71	2-60
RANGE CONTROL handwheel -----	2-71	2-60
RANGE EXTENSION METERS meter -----	2-70	2-60
RANGE METERS indicator -----	2-74	2-63
Strobe switch S105 -----	2-70	2-60

Transmitter fuse -----	2-68	2-58
VOLTAGE ADJ switch -----	2-69	2-59
Volume control -----	2-72	2-62
Power converter system:		
Block diagram -----	2-64	2-54
Flip-flop circuit -----	2-65	2-54
Rectifiers and filters -----	2-66	2-56
Ranging system:		
Block diagram -----	2-48	2-37
Comparator -----	2-51	2-42
Detector -----	2-53	2-46
Linear sweep -----	2-44	2-34
Range gate -----	2-52	2-46
Strobe -----	2-50	2-40
Receiver System:		
Blanketing and limiting -----	2-38	2-29
Block diagram -----	2-32	2-23
Frequency converter -----	2-33	2-23
IF amplifier Q501-Q505 -----	2-35	2-27
IF preamplifier Q508 -----	2-34	2-26
Video amplifier -----	2-37	2-29
Video detector -----	2-36	2-28
RF system:		
Afc coupler -----	2-27	2-20
Antenna -----	2-30	2-20
Balanced duplexer -----	2-26	2-18
Block diagram -----	2-24	2-16
Directional coupler -----	2-28	2-20
Energy flow -----	2-29	2-20
Waveguide -----	2-25	2-16
Transmitting System:		
Block diagram - -----	2-15	2-8
Magnetron V901 -----	2-21	2-15
Magnetron current filter -----	2-22	2-15
Modulator A201 -----	2-17	2-10
Negative gate circuit -----	2-19	2-15
Negative gate discharge circuit -----	2-20	2-15
Pulse unit Z20 -----	2-18	2-13
Thermal delay -----	2-16	2-10
Troubleshooting:		
Direct Support:		
Afc system -----	3-20	3-24
Age system -----	3-23	3-40
Audio system -----	3-22	3-37
Based on starting procedures -----	3-16	3-12
Fabrication of special cables -----	3-15	3-10
Four-layer diodes -----	3-10	3-5
Fuses -----	3-8	3-5
General procedures -----	3-3	3-2
Headsets -----	3-11	3-6
Interlock switch S1 -----	3-7, 3-25	3-5, 3-47
Intermittents -----	3-13	3-8
Parts substitution -----	3-12	3-8
Power cable -----	3-11	3-6
Power converter system -----	3-24	3-43
Ranging system -----	3-21	3-32
Receiving system -----	3-19	3-19
Replacing parts -----	3-6	3-4
RF system -----	3-18	3-19
Special test equipment required -----	3-14	3-8
Telescope -----	3-11	3-6
Telescope light cable -----	3-11	3-6
Transmitter system -----	3-17	3-15
Tubes, transistors, diodes -----	3-9	3-5

Voltage measurements -----	3-4	3-2
Waveform analysis -----	3-5	3-4
General Support:		
Afc control system -----	5-10	5-4
Afc search and control -----	5-22	5-14
Afc unit -----	5-23	5-15
Age system -----	5-13	5-5
Audio amplifier -----	5-26	5-17
Audio system -----	5-12	5-5
Based on starting procedures -----	5-7	5-2
Blanking pulse subchassis - -----	5-21	5-14
IF amplifier unit - -----	5-15	5-7
Power converter system -----	5-14	5-6
Range unit -----	5-24	5-15
Raging system -----	5-11	5-4
Receiving system -----	5-9	5-3
Strobe circuit -----	5-25	5-16
Transistor Q501 -----	5-20	5-13
Transistor Q602 -----	5-19	5-12
Transistor Q603 -----	5-18	5-12
Transistor Q504 -----	5-17	5-11
Transistor Q605 -----	5-16	5-10
Transmitting system -----	5 8	5-3

By Order of the Secretary of the Army:

W. C. WESTMORELAND,
General, United States Army,
Chief of Staff.

Official:

VERNE L. BOWERS
Major General, United States Army,
The Adjutant General.

DISTRIBUTION:

Active Army:

USASA (2)
 CNGB (1)
 AGSC-E (2)
 Dir of Trans (1)
 CofEngrs (1)
 CofSpts (1)
 TSG (1)
 USAARENED (2)
 USAIB (2)
 USAMB (10)
 USAMC (1)
 USASTRATCOM (4)
 USAMICOM (4)
 USATECOM (2)
 USAESC (70)
 USACDC (2)
 USACDC Agcy (1)
 USACDCEC (10)
 CONARC (5)
 ABADGOM (2)
 ARADCOM Rgn (2)
 OS Maj Comd (4)
 USARYIS (8)
 USARAL (8)
 LOGCOMD (5)
 USATACOM (8)
 MDW (1)
 Armies (2)
 Corps (2)
 Instl (2) except
 Ft Carson (19)
 Ft Gordon (10)
 Ft Huachuca (10)
 WSMR (8)
 1st Cav Div (8)
 Svc Colleges (2)
 USASCS (60)
 USASESS (40)
 USAADS (2)

USAFAS (2)
 USAIS (2)
 USAES (2)
 USAARMS (2)
 USAINTS (8)
 USACSS (5)
 Army Dep (2) except
 SAAD (80)
 LEAD (14)
 TOAD (14)
 ATAD (10)
 LEAD (7)
 NAAD (5)
 SVAD (5)
 Gen Dep (2)
 Sig Sec, Gen Dep (5)
 Sig Dep (10)
 APG (8)
 ATS (1)
 MAAG (1)
 USARMIS (1)
 USAERDAW (5)
 USAERDAA (2)
 USACRREL (2)
 WRAMC (1)
 SIG FLDMS (2)
 Units org under fol TOE:-2 as.
 11-97
 11-98
 11-117
 11-127
 11-158
 11-500 (AA-AC)
 29-16
 29-105
 29-134
 29-136
 29-138
 29-427

ARNG & USAR: None.

For explanation of abbreviation used, see AR 310-50.

COLOR CODE MARKING FOR MILITARY STANDARD CAPACITORS

GROUP I Capacitors, Fixed, Various-Dielectrics, Styles CM, CN, CY, and CB

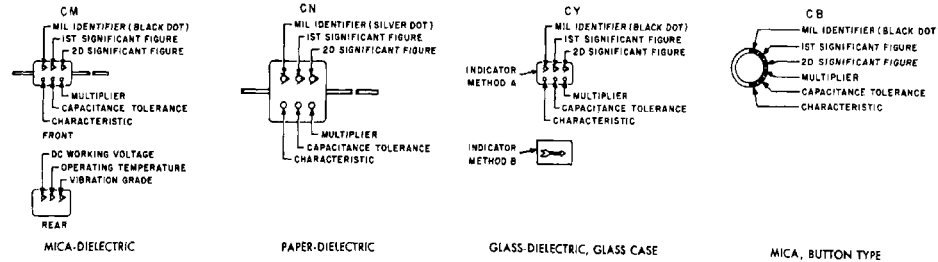

GROUP II Capacitors, Fixed Ceramic-Dielectric (General Purpose) Style CK

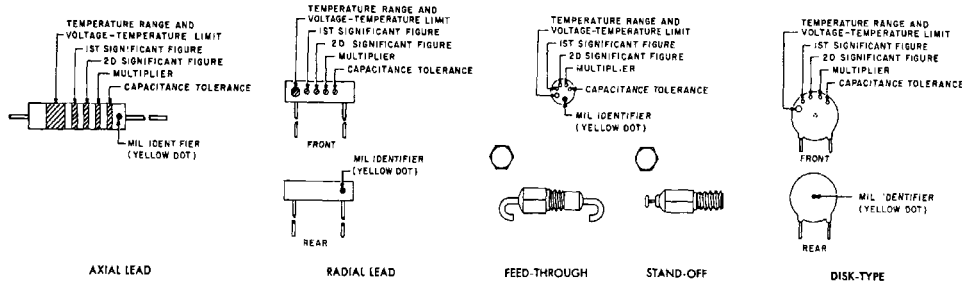

GROUP III Capacitors, Fixed, Ceramic-Dielectric (Temperature Compensating) Style CC

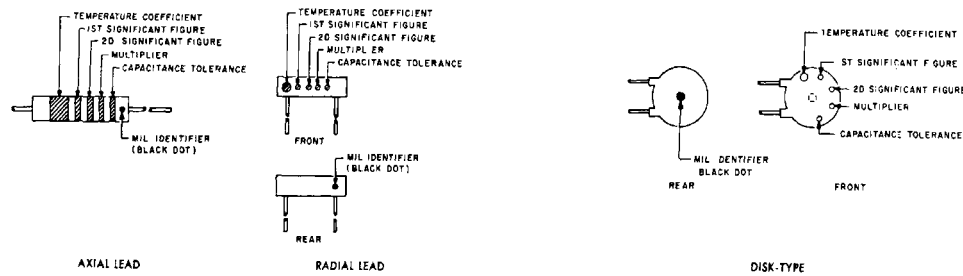

COLOR CODE TABLES

TABLE I - For use with Group I, Styles CM, CN, CY and CB

COLOR	MIL ID	1st SIG FIG	2nd SIG FIG	MULTIPLIER ¹	CAPACITANCE TOLERANCE				CHARACTERISTIC ²				DC WORKING VOLTAGE		OPERATING TEMP. RANGE	VIBRATION GRADE	
					CM	CN	CY	CB	CM	CN	CY	CB	CM	CM	CM		
BLACK	CM, CY, CB	0	0	1							A					-55° to +70°C	10-55 cps
BROWN		1	1	10							B	E	B				
RED		2	2	100	± 2%		± 2%	± 2%	C		C					-55° to +85°C	
ORANGE		3	3	1,000		± 30%			D		D		300				
YELLOW		4	4	10,000					E							-55° to +125°C	10-2,000 cps
GREEN		5	5				± 5%		F				500				
BLUE		6	6													-55° to +150°C	
PURPLE (VIOLET)		7	7														
GREY		8	8														
WHITE		9	9														
GOLD				0.1				± 5%	± 5%								
SILVER	CM				± 10%	± 10%	± 10%	± 10%									

TABLE II - For use with Group II, General Purpose, Style CK

COLOR	TEMP. RANGE AND VOLTAGE - TEMP. LIMITS ³	1st SIG FIG	2nd SIG FIG	MULT. PLIER ¹	CAPACITANCE TOLERANCE	MIL ID
BLACK		0	0	1	± 20%	
BROWN	AW	1	1	10	± 10%	
RED	AX	2	2	100		
ORANGE	BX	3	3	1,000		
YELLOW	AY	4	4	10,000		CK
GREEN	CY	5	5			
BLUE	BV	6	6			
PURPLE (VIOLET)		7	7			
GREY		8	8			
WHITE		9	9			
GOLD						
SILVER						

TABLE III - For use with Group III, Temperature Compensating, Style CC

COLOR	TEMPERATURE COEFFICIENT ⁴	1st SIG FIG	2nd SIG FIG	MULT. PLIER ¹	CAPACITANCE TOLERANCE		MIL ID
					Capacitances over 10µf	Capacitances 10µf or less	
BLACK	0	0	0	1		± 20µf	CC
BROWN	30	1	1	10	± 1%		
RED	80	2	2	100	± 2%	± 0.35µf	
ORANGE	150	3	3	1,000			
YELLOW	220	4	4				
GREEN	300	5	5		± 5%	± 0.5µf	
BLUE	470	6	6				
PURPLE (VIOLET)	750	7	7				
GREY		8	8	0.01			
WHITE		9	9	0.1	± 10%		
GOLD	± 100					± 1.0µf	
SILVER							

1. The multiplier is the number by which the two significant (SIG) figures are multiplied to obtain the capacitance in µf.
2. Letters indicate the Characteristics designated in applicable specifications: MIL-C-5, MIL-C-91, MIL-C-11272 and MIL-C-10950 respectively.
3. Letters indicate the temperature range and voltage-temperature limits designated in MIL-C-11015.
4. Temperature coefficient in parts per million per degree centigrade.

Figure 7-3. Color code markings for MIL-STD capacitors.

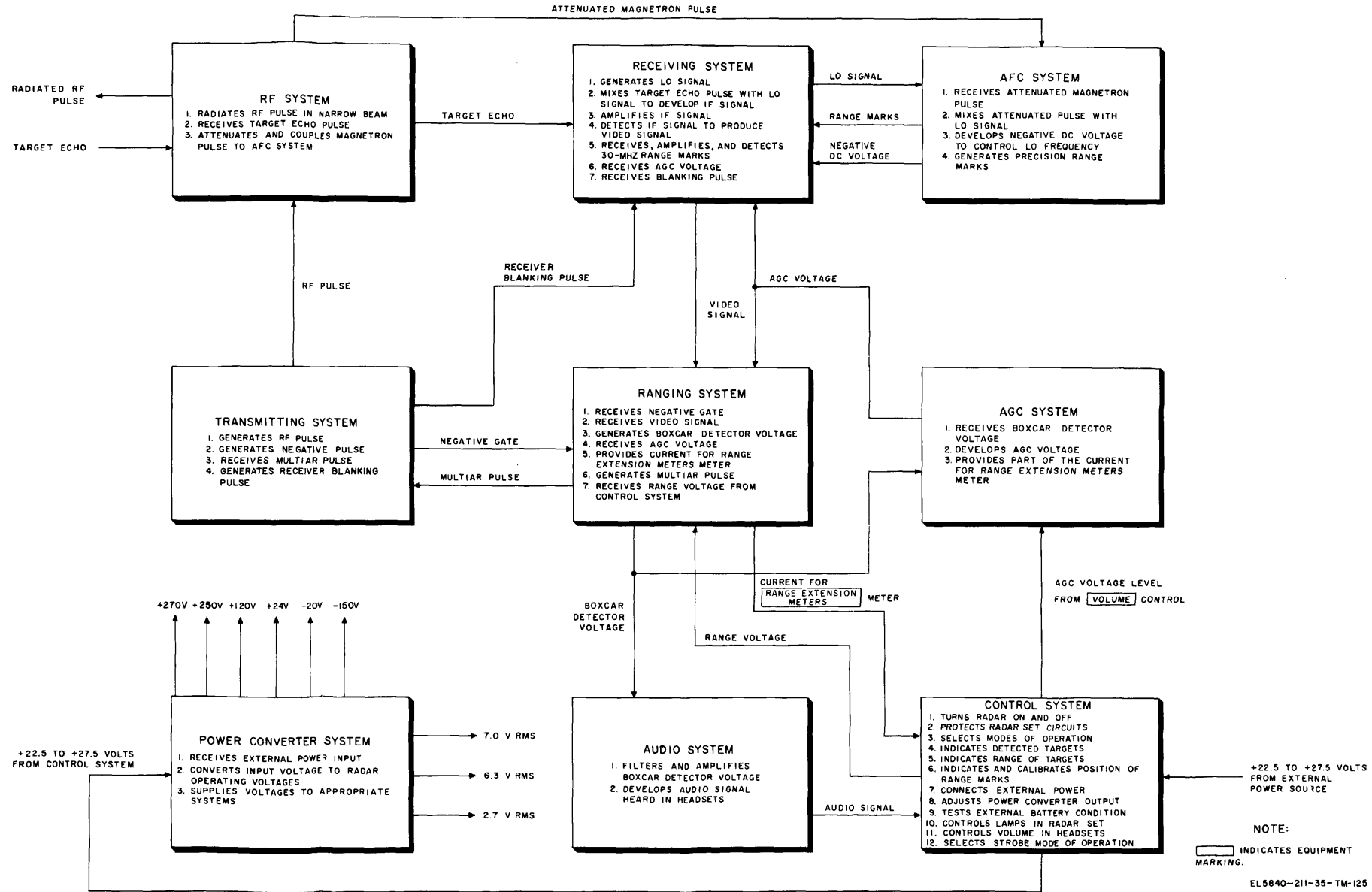

Figure 7-4. Radar Set AN/PPS-4A, system function block diagram.

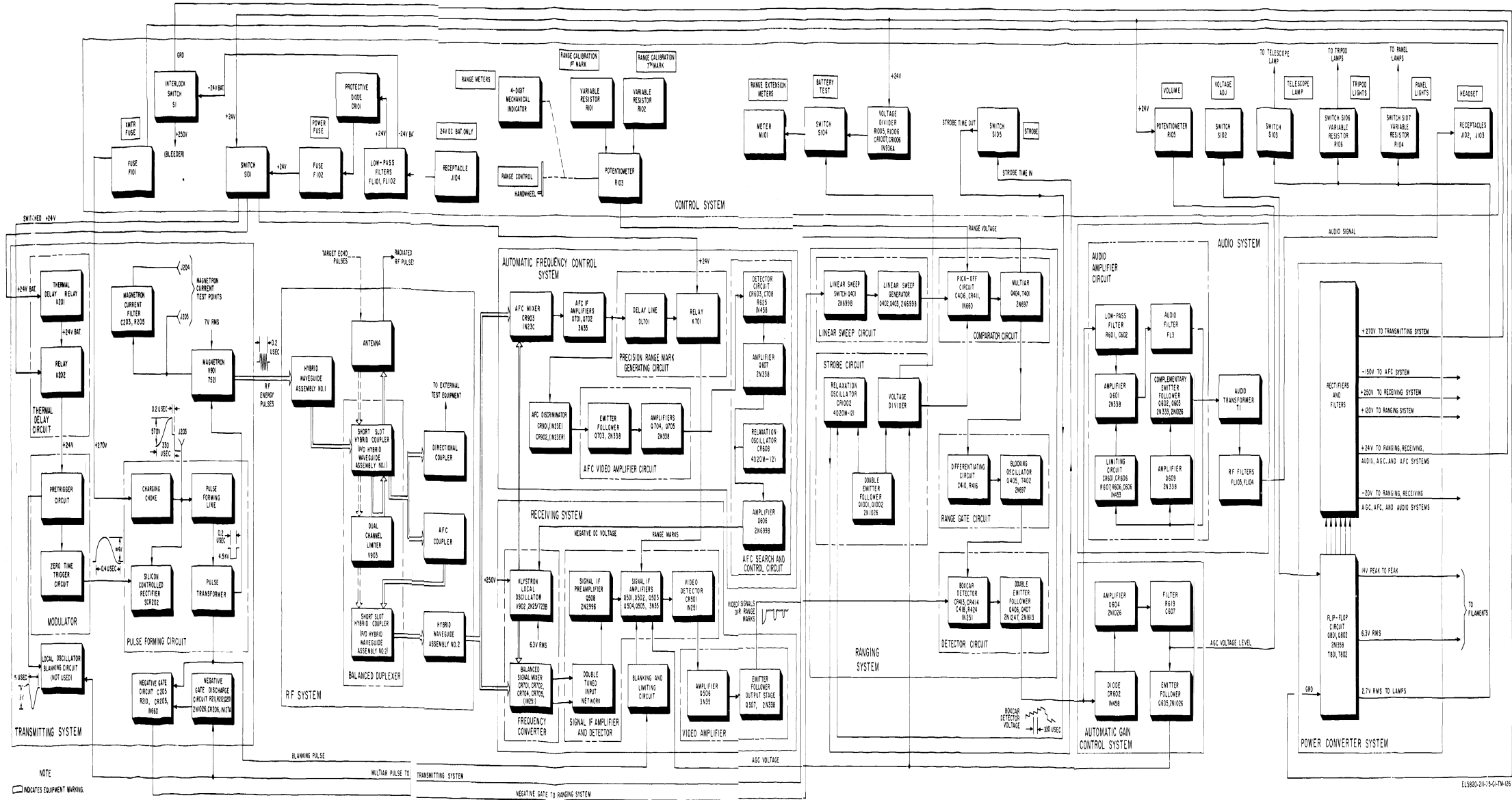

Figure 7-5. Radar Set AN/PPS-4A, complete block diagram.
Change 1 7-13

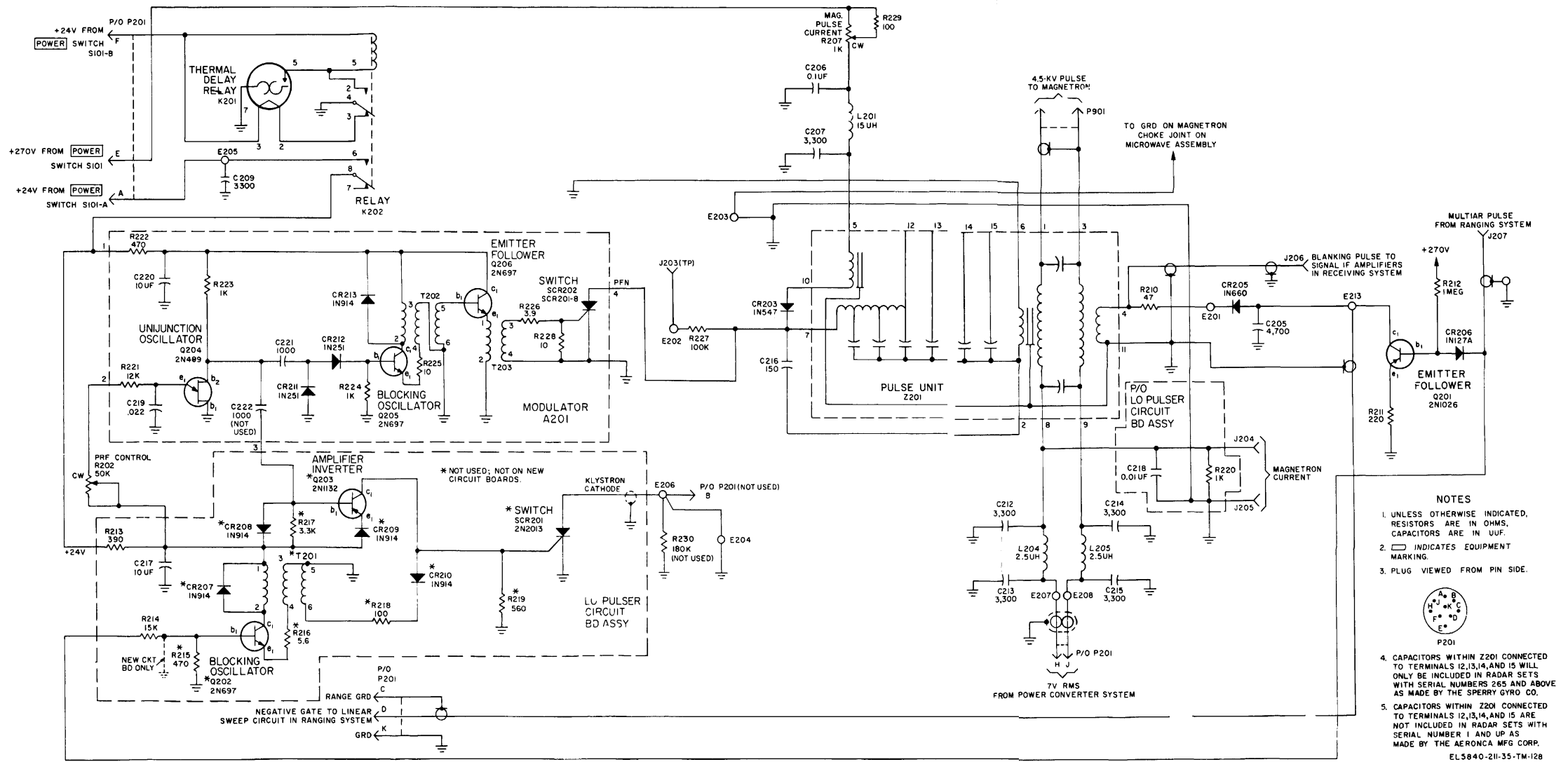

Figure 7-6. Transmitter unit, complete schematic diagram.

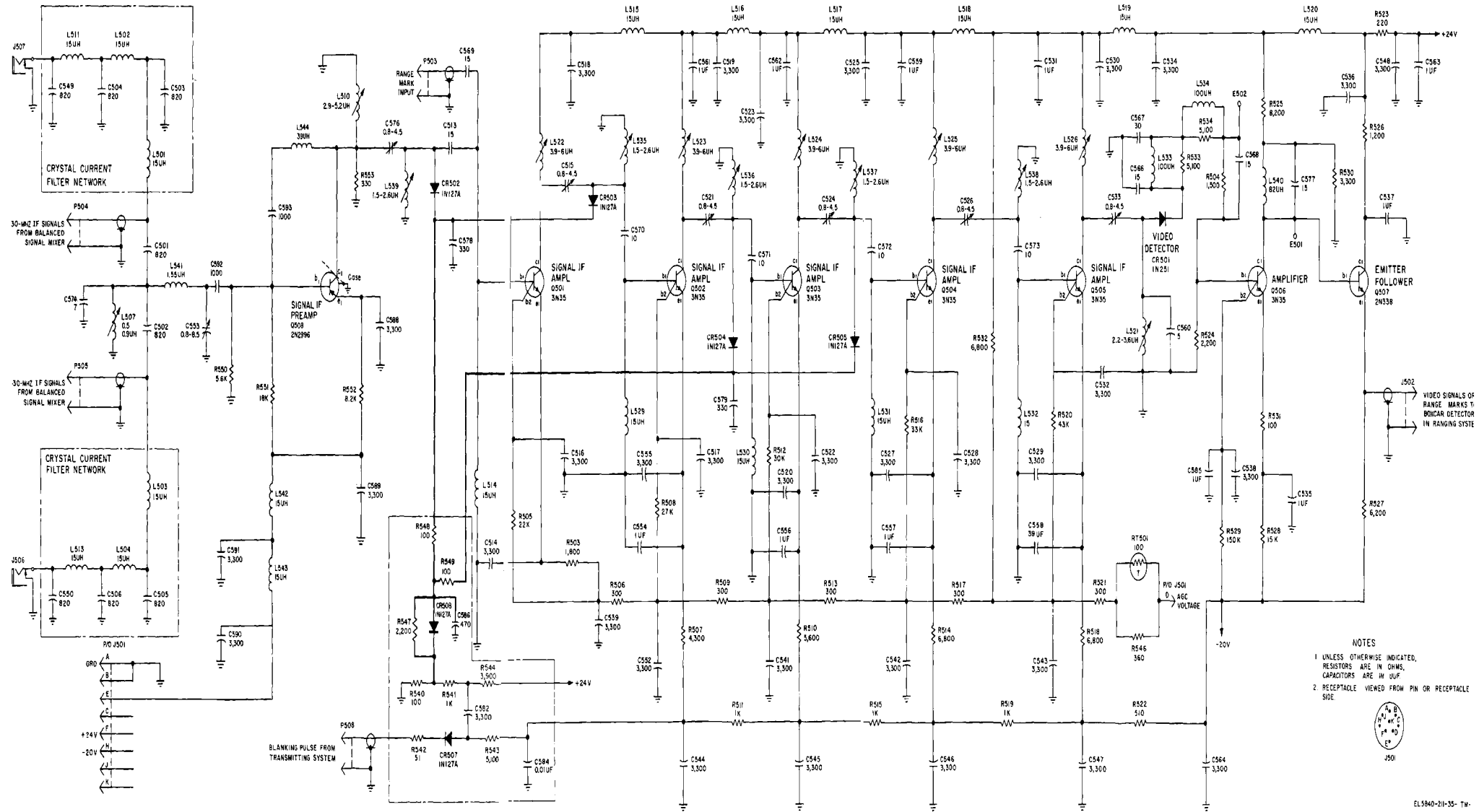

Figure 7-7. IF amplifier unit, complete schematic diagram
7-17

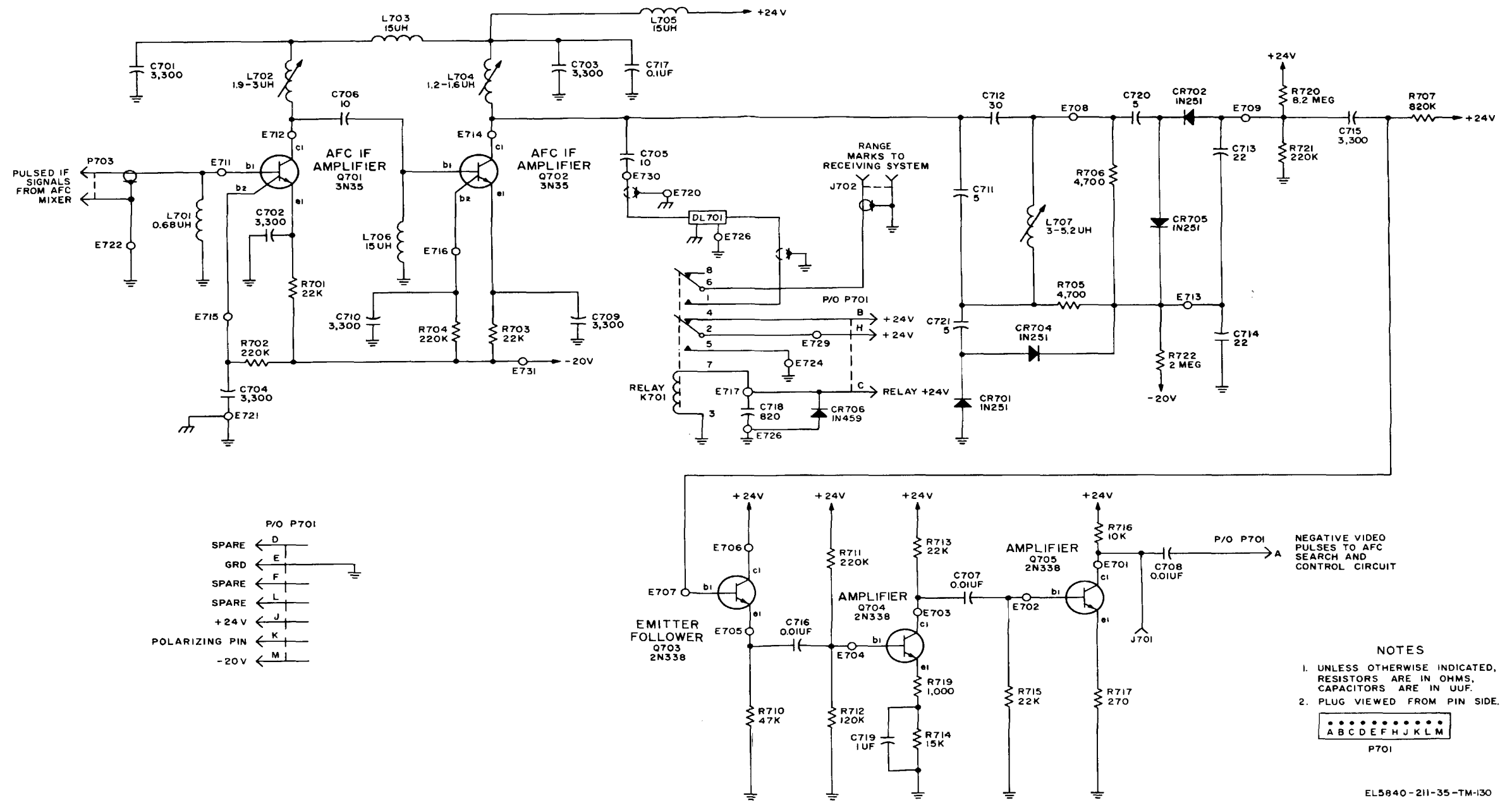
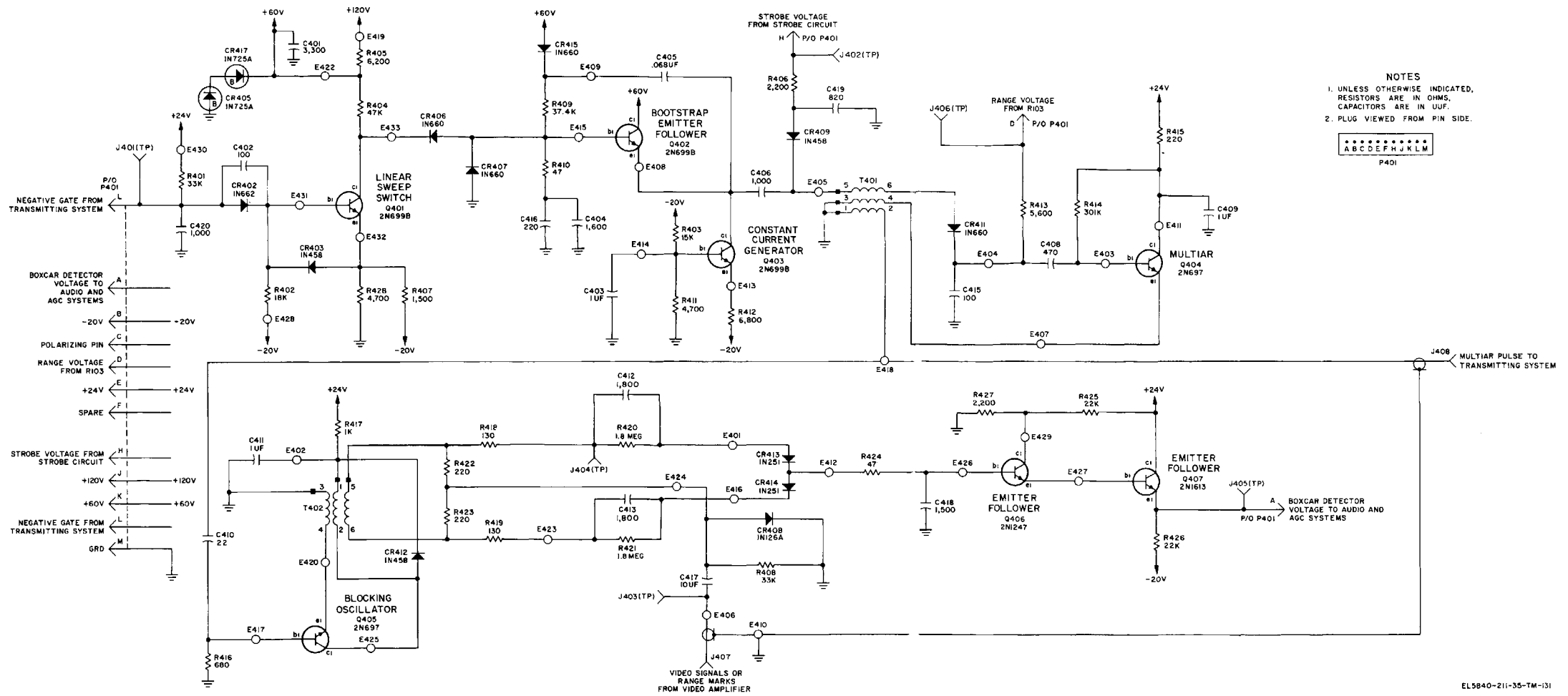
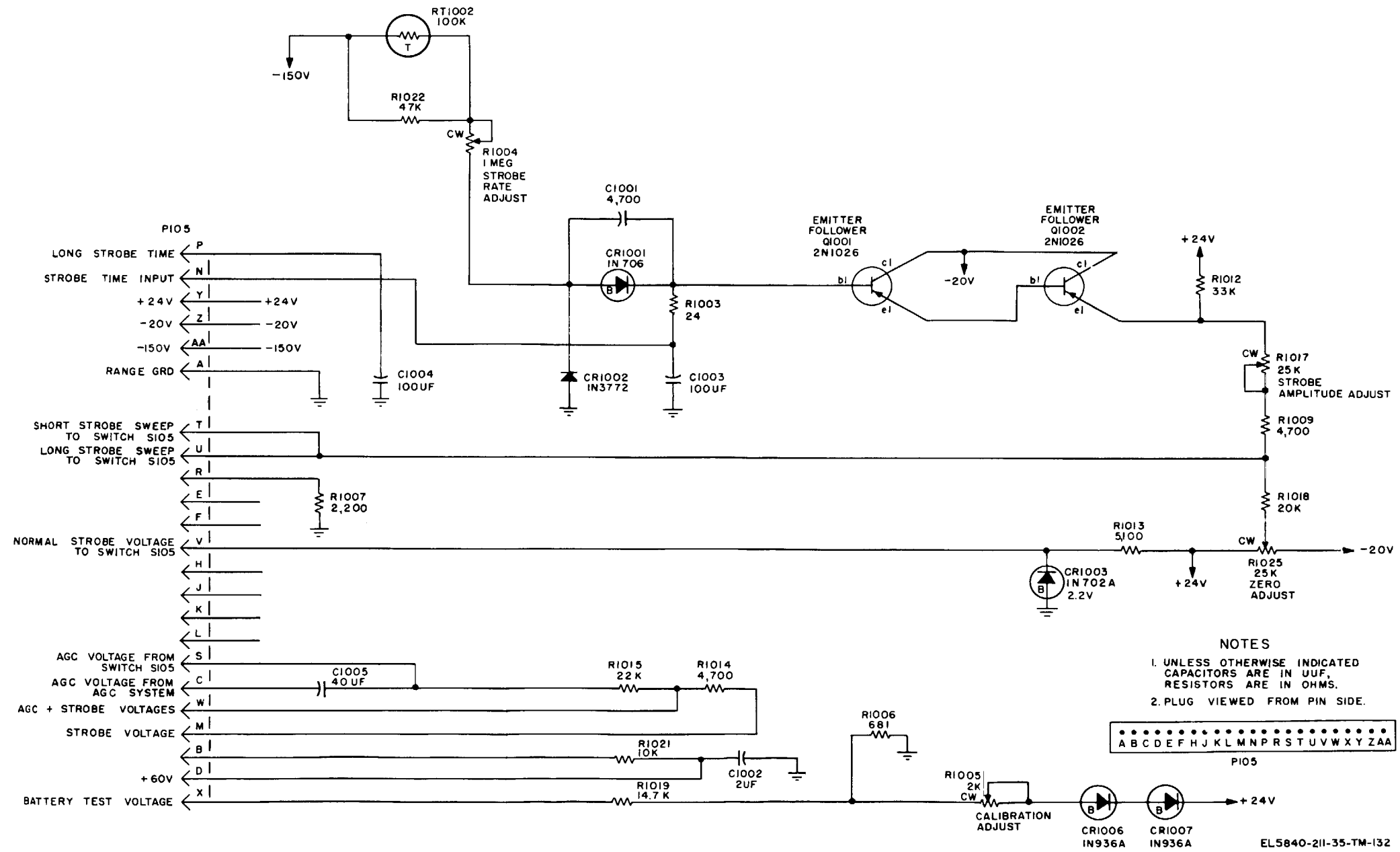

Figure 7-8. Afc unit, complete schematic diagram.
7-19



EL5840-211-35-TM-131

Figure 7-14. Radar Set AN/PPS-4A, interconnection diagram.
7-31



NOTES
 1. UNLESS OTHERWISE INDICATED CAPACITORS ARE IN UUF, RESISTORS ARE IN OHMS.
 2. PLUG VIEWED FROM PIN SIDE.

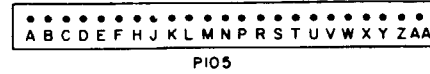

Figure 7-11. Audio unit, complete schematic diagram.
 7-25

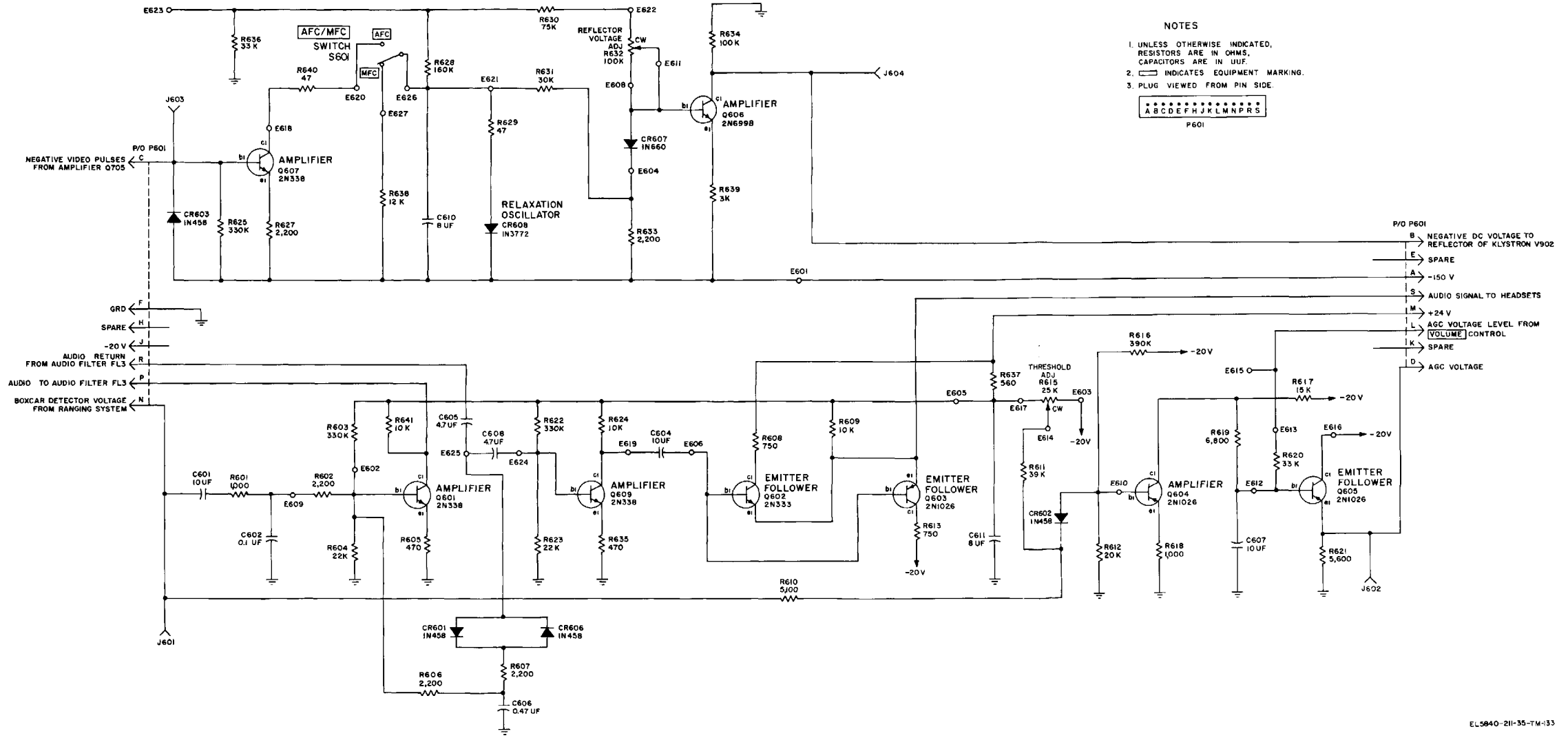

Figure 7-10. Strobe unit, complete schematic diagram.
7-23

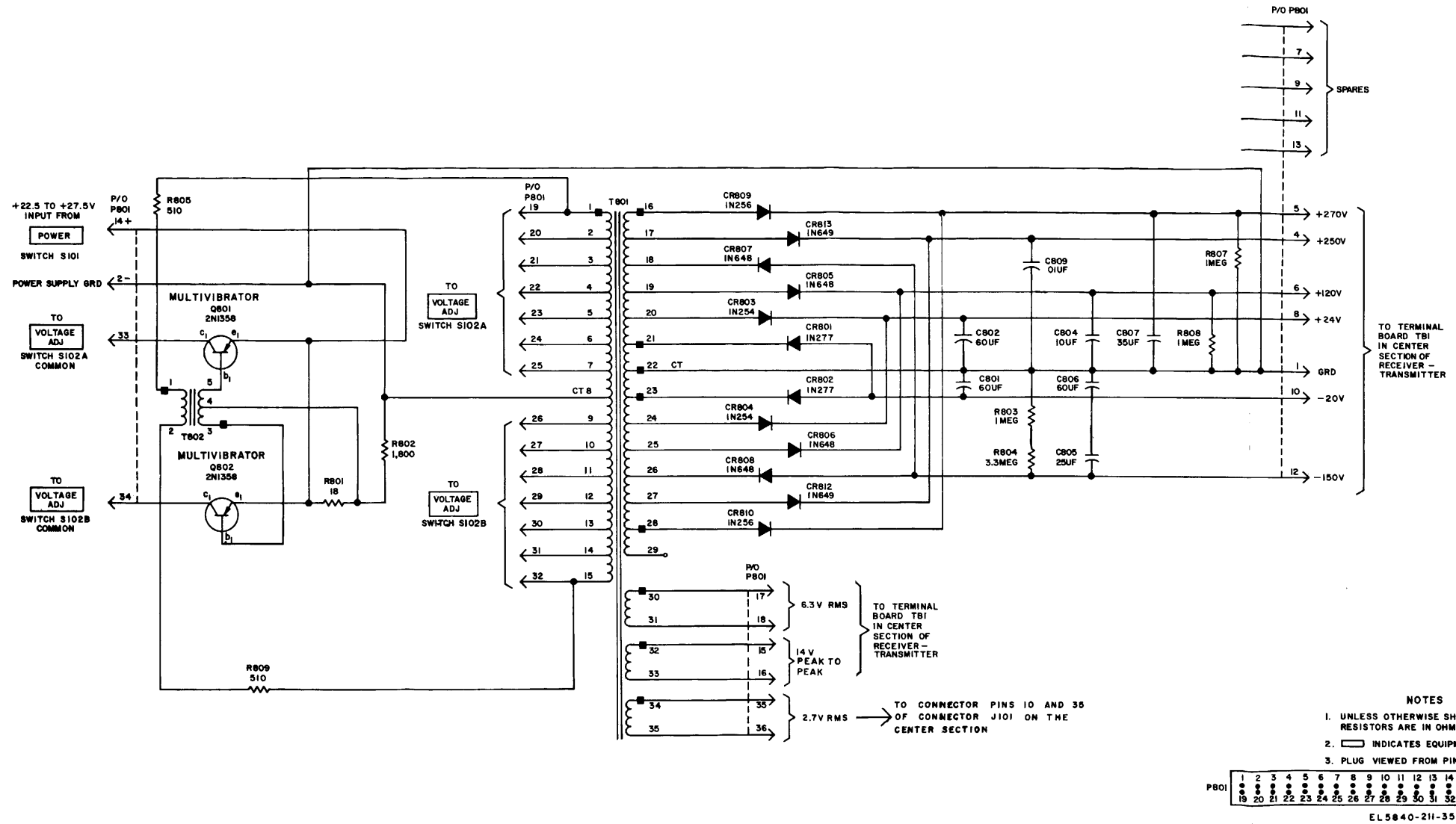
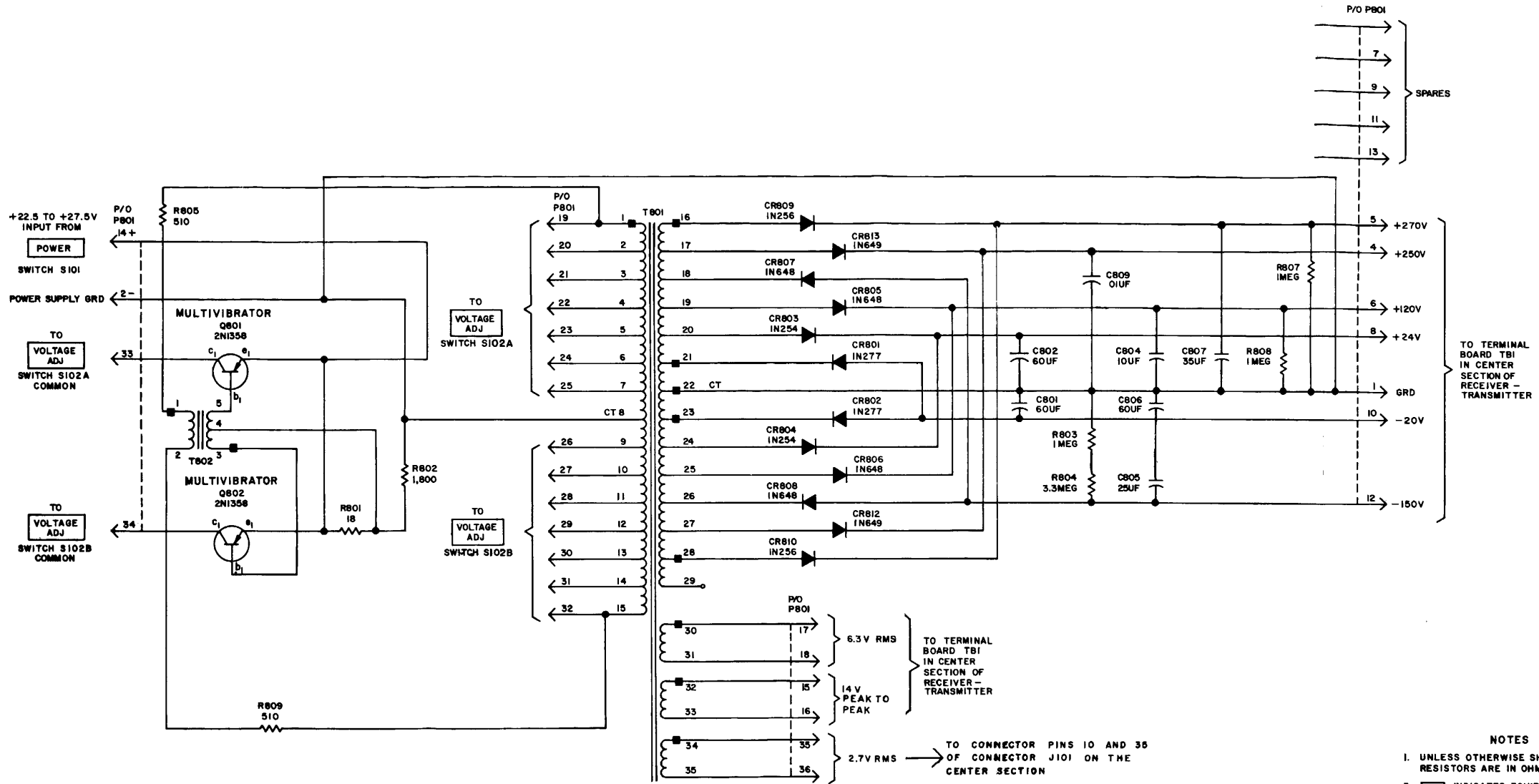

Figure 7-9. Range unit, complete schematic diagram 7-21



- NOTES**
- UNLESS OTHERWISE SHOWN RESISTORS ARE IN OHMS.
 - INDICATES EQUIPMENT MARKING.
 - PLUG VIEWED FROM PIN SIDE.
- | | | | | | | | | | | | | | | | | | | |
|------|----|----|----|----|----|----|----|----|----|----|----|----|----|----|----|----|----|----|
| P801 | 1 | 2 | 3 | 4 | 5 | 6 | 7 | 8 | 9 | 10 | 11 | 12 | 13 | 14 | 15 | 16 | 17 | 18 |
| | 19 | 20 | 21 | 22 | 23 | 24 | 25 | 26 | 27 | 28 | 29 | 30 | 31 | 32 | 33 | 34 | 35 | 36 |

EL 5840-211-35-C4-TM-154

Figure 7-12. Power Converter, complete schematic diagram.
Change 4 7-27

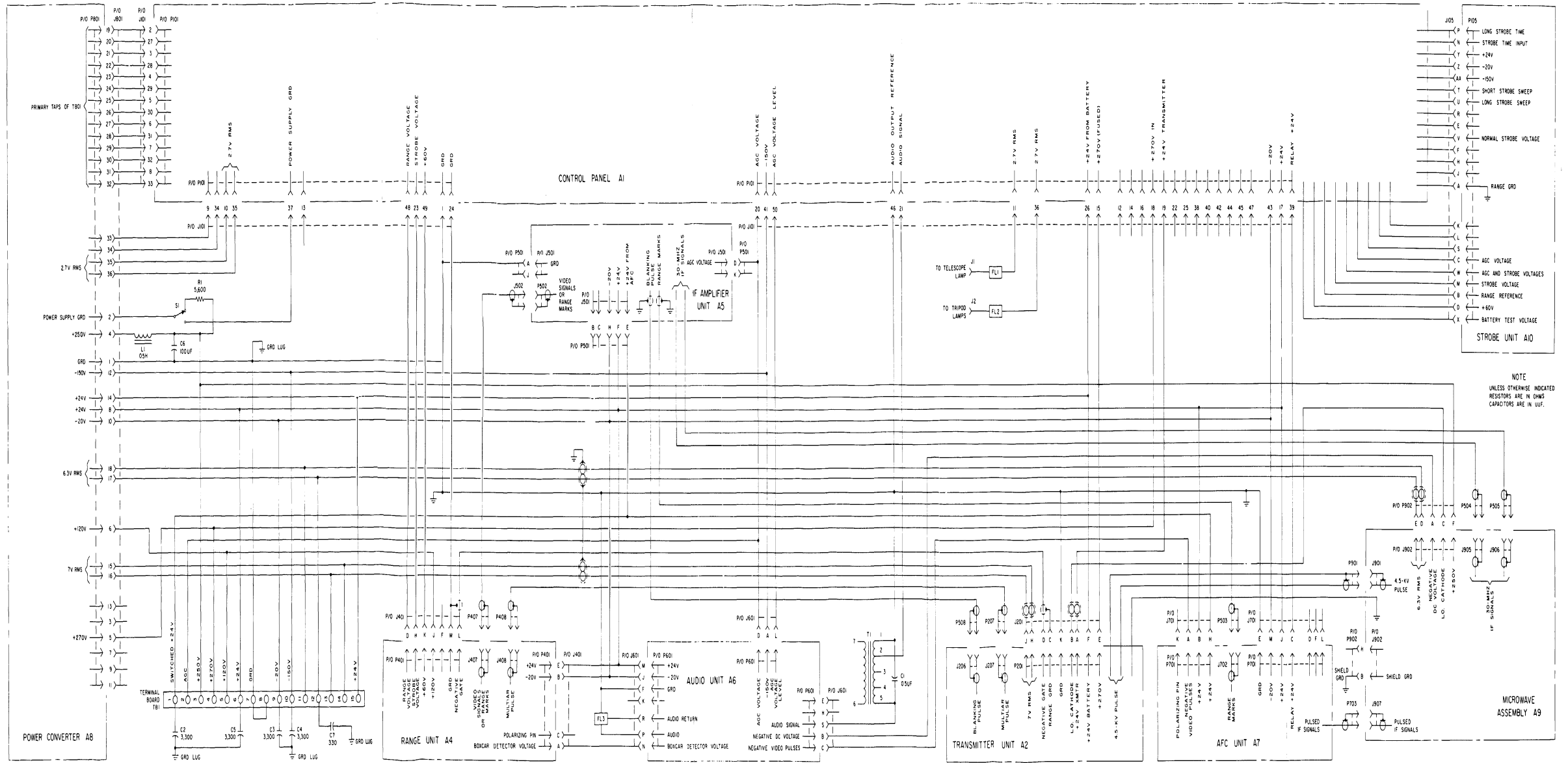

Figure 7-13. Control panel, complete schematic diagram.
Change 4 7-29

RECOMMENDED CHANGES TO EQUIPMENT TECHNICAL PUBLICATIONS



THEN... JOT DOWN THE DOPE ABOUT IT ON THIS FORM. CAREFULLY TEAR IT OUT, FOLD IT AND DROP IT IN THE MAIL!

SOMETHING WRONG WITH THIS PUBLICATION?

FROM: (PRINT YOUR UNIT'S COMPLETE ADDRESS)

DATE SENT

PUBLICATION NUMBER

PUBLICATION DATE

PUBLICATION TITLE

BE EXACT... PIN-POINT WHERE IT IS

PAGE NO.

PARA-GRAPH

FIGURE NO.

TABLE NO.

IN THIS SPACE TELL WHAT IS WRONG AND WHAT SHOULD BE DONE ABOUT IT:

TEAR ALONG PERFORATED LINE

PRINTED NAME, GRADE OR TITLE, AND TELEPHONE NUMBER

SIGN HERE:

